

SHARP

SUPPLEMENTAL SERVICE MANUAL

S42M323R18OR4Y

OVER THE RANGE MICROWAVE MODELS R-1871TY / R-1874TY / R-1875TY

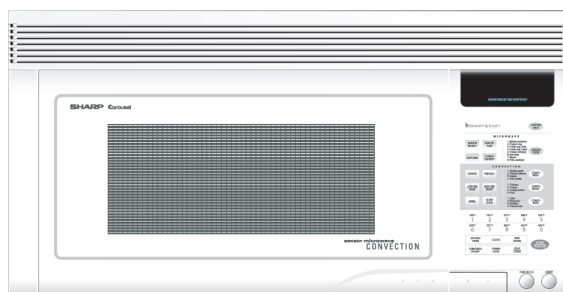

R-1871TY pictured



R-1874TY pictured



R-1875TY pictured

THIS SERVICE MANUAL IS FOR MODELS USING THE STANDBY POWER CIRCUIT.

**MODELS NOT USING STANDBY POWER, PLEASE REFER TO SERVICE MANUAL:
(R-1871-T / R-1872-T / R-1874-T / R-1875-T) - S42M323R18OR4**

This is a supplemental Service Manual for Models R-1871TY, R-1874TY and R-1875TY. Use this supplemental manual together with the following base models for complete operation, service information, etc. R-1871TY (base model R-1850), R-1874TY and R-1875TY (base model R-1855)

In the interest of user-safety the unit should be restored to its original condition and only parts identical to those specified should be used.

WARNING TO SERVICE PERSONNEL:

This service manual is intended for use by persons having electrical and mechanical training and a level of knowledge of these subjects generally considered acceptable in the appliance repair trade. Sharp Electronics Corporation cannot be responsible, nor assume any liability, for injury or damage of any kind arising from the use of this manual.

Microwave ovens contain circuitry capable of producing very high voltage and current. Contact with the following parts may result in a severe, possibly fatal, electrical shock. (High Voltage Capacitor, High Voltage Power Transformer, High Voltage Rectifier, Heat sink, Magnetron, and High Voltage Harness etc..)

SHARP ELECTRONICS CORPORATION

This document has been published to be used for after sales service only. The contents are subject to change without notice.

SUPPLEMENTAL SERVICE MANUAL

SHARP

OVER THE COUNTER MICROWAVE OVEN

R-1871TY / R-1874TY / R-1875TY

FOREWORD

This Manual has been prepared to provide Sharp Electronics Corp. Service Personnel with Operation and Service Information for the SHARP OVER THE RANGE MICROWAVE OVENS using the Standby Power Circuit.

It is recommended that service personnel carefully study the entire text of this manual so that they will be qualified to render satisfactory customer service.

Check the interlock switches and the door seal carefully. Special attention should be given to avoid electrical shock and microwave radiation hazard.

WARNING

Never operate the oven until the following points are ensured.

- (A) The door is tightly closed.
- (B) The door brackets and hinges are not defective.
- (C) The door packing is not damaged.
- (D) The door is not deformed or warped.
- (E) There is not any other visible damage with the oven.

Servicing and repair work must be carried out only by trained service personnel.

DANGER

Certain initial parts are intentionally not grounded and present a risk of electrical shock only during servicing. Service personnel - Do not contact the following parts while the appliance is energized; High Voltage Capacitor, Power Transformer, Magnetron, High Voltage Rectifier Assembly, High Voltage Harness; If provided, Vent Hood, Fan assembly, Cooling Fan Motor.

All the parts marked “*” on parts list are used at voltages more than 250V.

Removal of the outer wrap gives access to voltage above 250V.

All the parts marked “Δ” on parts list may cause undue microwave exposure, by themselves, or when they are damaged, loosened or removed.

BEFORE SERVICING

Before servicing an operative unit, perform a microwave emission check as per the Microwave Measurement Procedure outlined in this service manual.

If microwave emissions level is in excess of the specified limit, contact SHARP ELECTRONICS CORPORATION immediately @ 1-800-237-4277.

If the unit operates with the door open, service person should 1) tell the user not to operate the oven and 2) contact SHARP ELECTRONICS CORPORATION and Food and Drug Administration's Center for Devices and Radiological Health immediately.

Service personnel should inform SHARP ELECTRONICS CORPORATION of any certified unit found with emissions in excess of 4mW/cm². The owner of the unit should be instructed not to use the unit until the oven has been brought into compliance.

SHARP ELECTRONICS CORPORATION

SHARP PLAZA, MAHWAH,
NEW JERSEY 07430-2135

SCHEMATIC
NOTE: CONDITION OF OVEN
1. Door Closed
2. CLOCK APPEARS ON DISPLAY

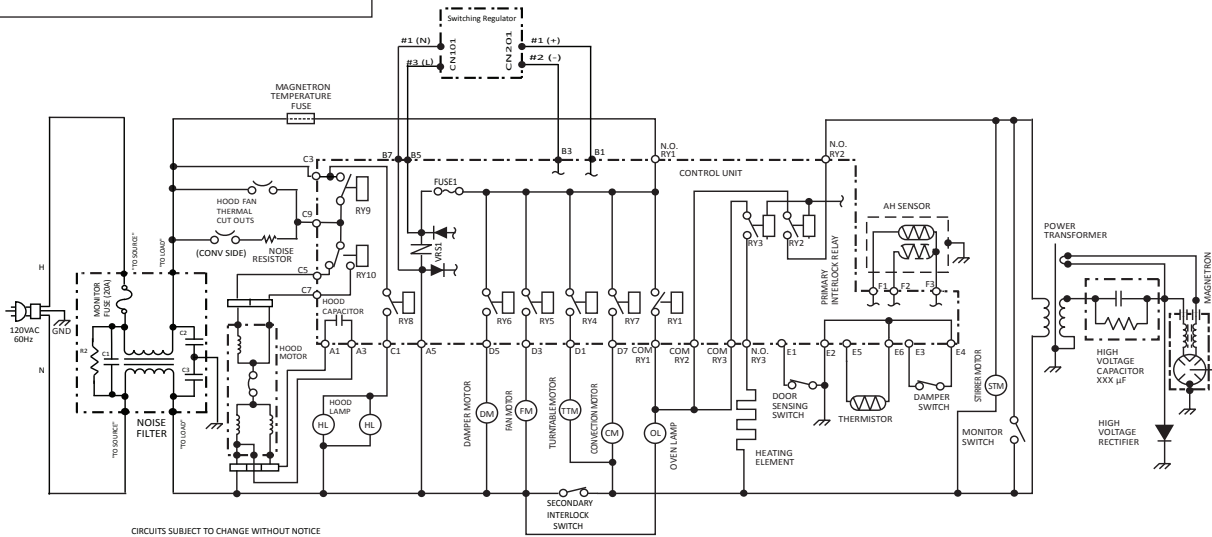

R-1871TY Oven Schematic - Off Condition

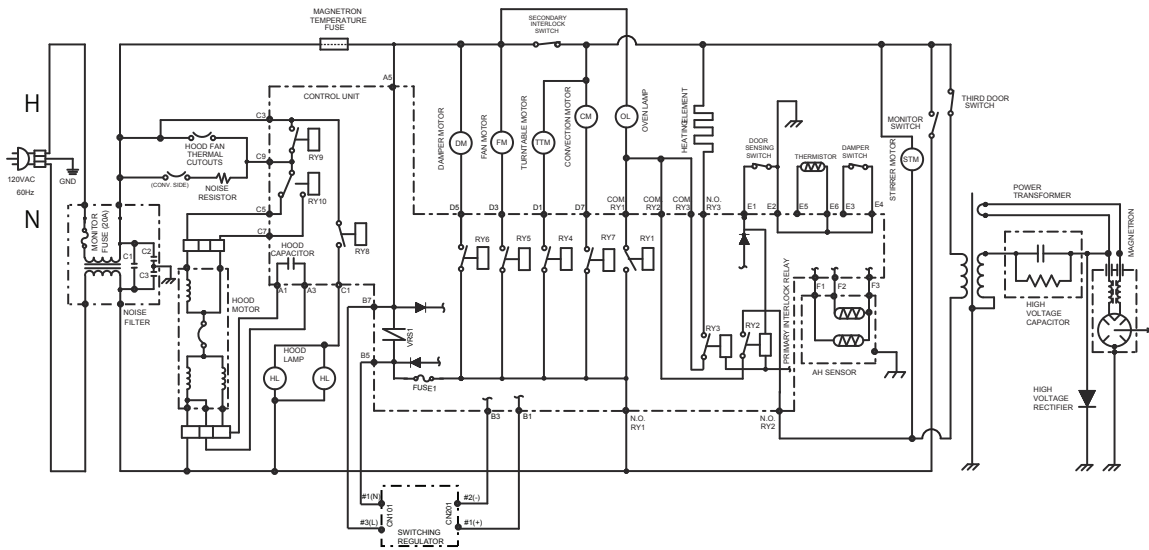

Circuits / Wire colors subject to change without notice

R-1874TY & R-1875TY Oven Schematic - Off Condition

SWITCHING POWER SUPPLY TEST PROCEDURE

1. Check AC power into CN101,
if none check Main Harness.
2. Check DC power across CN201 (DC15V),
if none replace **Switching Power Supply Unit**
3. Check for DC getting from **Switching Power Supply Unit** to PSU/ CPU, if none check Main Harness.

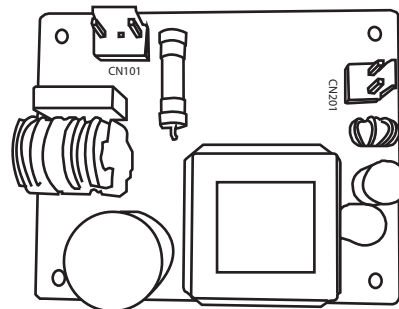

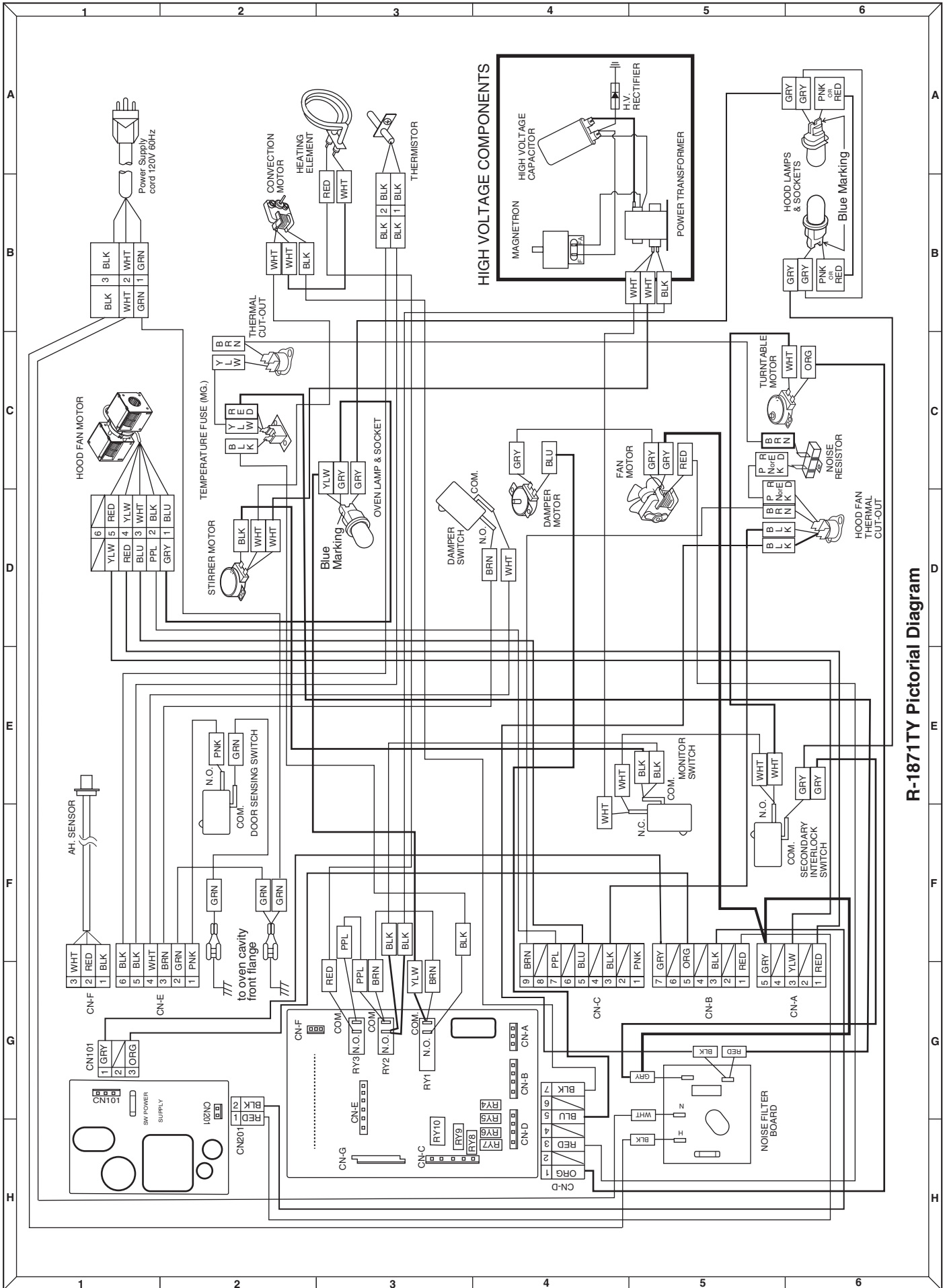

R-1871TY Pictorial Diagram

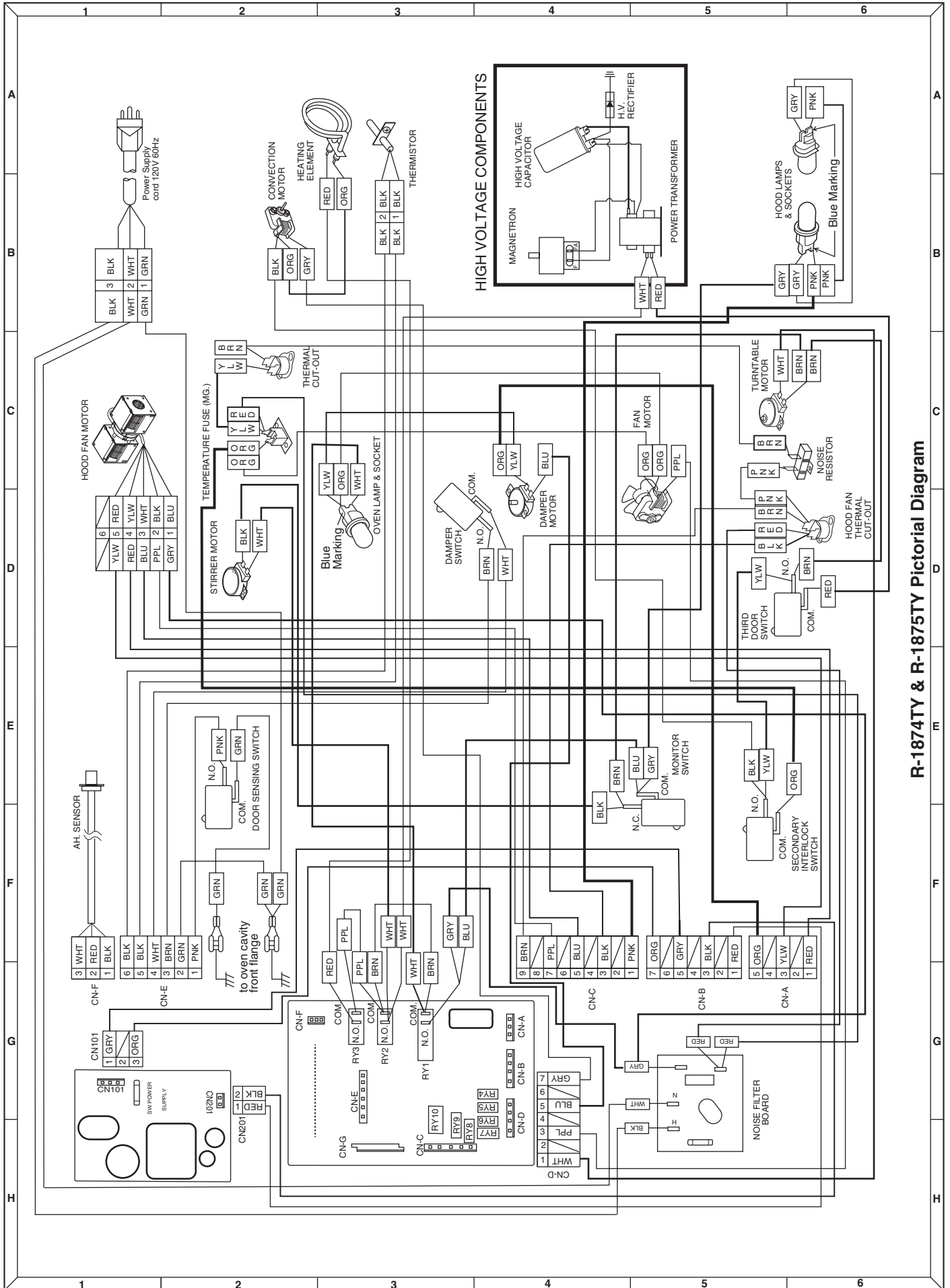

R-1874TY & R-1875TY Pictorial Diagram

PARTS LIST

Note: The parts marked "Δ" may cause undue microwave exposure.
The parts marked "*" are used in voltage more than 250V.

REF. NO.	PART NO.	DESCRIPTION	Q'TY	CODE
ELECTRIC PARTS				
* 1- 1	FC-QZA622WRKZ	High voltage capacitor assembly	1	AX
1- 2	FPWBFA515WRKZ	Noise filter	1	AN
1- 3	QFS-TA013WRE0	Temperature fuse 150°C	1	AG
1- 4	RMOTDA256WRZZ	Damper motor	1	AP
1- 5	RMOTDA252WRZZ	Turntable motor	1	AN
1- 6	RMOTDA258WRZZ	Stirrer motor	1	AQ
1- 7	RTHM-A181WRZZ	Thermal cut-out N.O. 60°C	2	AF
1- 8	RTRN-B092MRE0	Power transformer	1	BK
* 1- 9	RV-MZA407WRZZ	Magnetron	1	BC
Δ* 1-10	DPWB-B451DRKZ	Switching power supply	1	AZ
1-11	QSW-MA085WRE0	Damper switch	1	AF
1-12	QFS-BA009WRE0	Fuse 20A (order with 1-24)	1	AF
1-13	FACCDB011MRE0	Power supply cord	1	AV
1-14	QSOCLB010MRE0	Hood lamp socket	2	AH
1-15	FDTCTA217WRKZ	AH sensor	1	AV
1-16	QSOCLA021WRE0	Oven lamp socket	1	AG
1-17	FMOTEA582WRKZ	Hood fan motor	1	BE
1-18	RR-WZA031WRE0	Noise resistor	1	AP
1-19	RMOTEB032MRE0	Fan motor	1	AZ
1-20	RLMPTA086WRZZ	Hood lamp and oven lamp	3	AL
1-21	RC-QZA331WRZZ	HV capacitor	1	AR
1-22	FH-DZB032MRY0	HV rectifier	1	AM
1-23	QSW-MA168WRZZ	Switches (R-1874/75TY)	3	AF
1-23	QSW-MA168WRZZ	Switches (R-1871TY)	2	AF
1-24	QSW-MA169WRZZ	Monitor switch	1	AD

CABINET PARTS

2- 1	PFIL-B005MRE0	Grease filter	2	AM
2- 2	PDIF-A052WRFZ	Hood exhaust louver (R-1871TY)	1	AU
2- 2	FDIF-B013MRK0	Hood exhaust louver (R-1874TY)	1	AY
2- 2	PDIF-A053WRFZ	Hood exhaust louver (R-1875TY)	1	AU
2- 3	GDAI-A463WRWZ	Base plate right	1	AQ
2- 4	GDAI-A462WRWZ	Base plate left	1	AM
2- 5	FCABUA987WRKZ	Outer case cabinet (R-1871TY)	1	BM
2- 5	FCABUA989WRKZ	Outer case cabinet (R-1874TY/R-1875TY)	1	BG
2- 6	TMAPCA829WRRZ	Schematic diagram (R-1871TY)	1	AE
2- 6	TMAPCA834WRRZ	Schematic diagram (R-1874TY/R-1875TY)	1	AE
2- 7	FANGKB029MRY0	Hood lamp glass assembly (R-1871TY)	1	AQ
2- 7	FANGKB009MRY0	Hood lamp glass assembly (R-1874TY/R-1875TY)	1	AP
2-7-1	LANGQB082MRP0	Hood lamp glass angle (R-1871TY)	1	AN
2-7-1	LANGQB016MRP0	Hood lamp glass angle (R-1874TY/R-1875TY)	1	AM
2-7-2	PGLSPB004MRE0	Hood lamp glass	1	AQ
2- 8	PCOVPA555WRTZ	Base cover (R-1871TY)	1	AZ
2- 8	PCOVPA565WRTZ	Base cover (R-1874TY/R-1875TY)	1	BA
2- 9	HDECQA468WRFZ	Sash left (R-1871TY)	1	AL
2- 9	FDECAB028MRK0	Sash left (R-1874TY)	1	AR
2- 9	HDECQA472WRFZ	Sash left (R-1875TY)	1	AL
2-10	LSTY-A122WRWZ	Rear stay	1	AK

CONTROL PANEL PARTS

3- 1	CPWBFB151MRU0	Control unit	1	AZ
3- 2	FPNLCC062WRKZ	Control panel sub. assembly (R-1871TY)	1	BC
3- 2	FPNLCCB407MRK0	Control panel sub. assembly (R-1874TY)	1	BF
3- 2	FPNLCC064WRKZ	Control panel sub. assembly (R-1875TY)	1	BC
3- 3	MSPRCA045WRE0	Open button spring	1	AA
3- 4	JBTN-B632WRFZ	Open button (R-1871TY)	1	AE
3- 4	FDECAB029MRK0	Open button assy (R-1874TY)	1	AT
3- 4	JBTN-B636WRFZ	Open button (R-1875TY)	1	AG
3- 5	XEPS730P08XS0	Screw	3	AB
3- 6	XHPS730P08XS0	Screw	2	AB
3- 7	JBTN-B633WRFZ	Select button (R-1871TY)	1	AB
3- 7	JBTN-B637WRFZ	Select button (R-1875TY)	1	AF
3- 8	PCUSGA811WRPZ	Cushion (R-1871TY/R-1875TY)	1	AB
3- 9	GMADIA220WRFZ	Display window (R-1871TY/R-1875TY)	1	AG

REF. NO.	PART NO.	DESCRIPTION	QTY	CODE
----------	----------	-------------	-----	------

OVEN PARTS

4- 1	FFTA-B004MRK0	Exhaust damper assembly	1	AM
4- 2	FROLPB027MRK0	Turntable support assembly	1	AX
4- 3	NTNT-A146WREZ	Turntable tray	1	AY
4- 4	LANGKB463WRPZ	Capacitor holder	1	AF
4- 5	FCOVPA068WRYZ	Stirrer cover assembly	1	AQ
4- 6	FFAN-A002WRKZ	Stirrer fan assembly	1	AR
4- 7	-----	Oven cavity (not replaceable)	1	-
4- 8	DHET-B002MRK01	Convection heater unit	1	BS
4- 9	NCPL-B007MRF0	Coupling	1	AN
4-10	PCUSGA786WRPZ	Cushion	2	AH
4-11	PCUSUA663WRPZ	Cushion	1	AH
4-12	PPACGA189WREZ	Turntable motor packing	1	AG
4-13	PCUSUA662WRPZ	Cushion	2	AH
4-14	PFPF-A313WREZ	Heat protect	1	AQ
4-15	PHOK-A182WRFZ	Latch hook	1	AG
4-16	FANGTA175WRYZ	Unit mounting plate	1	AY
4-17	PFPF-A310WREZ	Heat protect	1	AH
4-18	LANGQA811WRPZ	Noise filter angle	1	AF
4-19	PDUC-B161WRWZ	Exhaust duct B	1	AF
4-20	PDUC-B167WRWZ	Hood intake duct L	1	AK
4-21	NFANJA069WREZ	Fan blade	1	AG
4-22	GBDYRA014WRWZ	Back plate	1	AX
4-23	FDUC-A506WRKZ	Fan duct	1	AP
4-24	LBSHCA014WRE0	Cord bushing	1	AG
4-25	FDUC-A503WRKZ	Exhaust duct (R-1871TY/R-1875TY)	1	AZ
4-25	FDUC-A509WRKZ	Exhaust duct (R-1874TY)	1	AZ
4-26	MLEVPB016MRF1	Open lever	1	AD
4-27	PCUSGA788WRPZ	Cushion	1	AF
4-28	MCAMPA187WRFZ	Damper cam	1	AF
4-29	PCUSUA666WRPZ	Damper cushion	1	AF
4-30	PFPF-A310WREZ	Heat protect R	1	AH
4-31	PFTA-A041WRPZ	Damper plate	1	AF
4-32	PREFHA091WRWZ	Thermal cover R	1	AQ
4-33	LANGQA812WRPZ	Hood lamp angle	1	AK
4-34	PREFHA092WRPZ	Thermal cover bottom	1	AP
4-35	LSTPPB024MRF0	Door stopper	1	AF
4-36	PCOVPA558WRWZ	Oven lamp cover	1	AG
4-37	PCOVPA559WRPZ	Heat protect top sheet	1	AK
4-38	PCUSGA789WRPZ	Cushion	1	AF
4-39	PDUC-B162WRFZ	Hood exhaust duct	1	AZ
4-40	PDUC-B165WRPZ	Top duct	1	AR
4-41	PDUC-B164WRFZ	Magnetron duct	1	AH
4-42	PDUC-B166WRPZ	Hood intake duct R	1	AM
4-43	PFILWA035WRE0	Oven light screen	1	AK
4-44	PFPF-A312WREZ	Heat protect top	1	AR
4-45	PCUSUA673WRPZ	Exhaust cushion A	1	AE
4-46	PCUSGA792WRPZ	Exhaust cushion B	2	AF
4-47	PCUSUA668WRPZ	Cushion	1	AF
4-48	PCUSUA669WRPZ	Cushion	2	AF
4-49	PCUSUA670WRPZ	Cushion	1	AF
4-50	LHLDPB004MRF0	PWB holder	1	AC

DOOR PARTS

5- 1	CDORFB286MRK0	Door assembly (R-1871TY)	1	BQ
5- 1	CDORFB312MRK0	Door assembly (R-1874TY)	1	BR
5- 1	CDORFB285MRK0	Door assembly (R-1875TY)	1	BQ
5- 2	GCOVHB031MRF0	Choke cover	1	AY
5- 3	LSTPPB025MRF0	Latch head	1	AH
5- 4	MSPRTA046WRE0	Latch spring	1	AD

REF. NO.	PART NO.	DESCRIPTION	Q'TY	CODE
MISCELLANEOUS				
6- 1	CFZK-B659WRKZ	Installation material assembly	1	AW
6-1-1	LBSHC0040MRE0	Grommet	1	AF
6-1-2	LX-BZ0195WRE0	Toggle screw	4	AH
6-1-3	XBRS750P60000	Screw : 5mm x 60mm	2	AK
6-1-4	XOTS740P12000	Screw : 4mm x 12mm	1	AB
6-1-5	XTSS750P35000	Screw : 5mm x 35mm	6	AD
6-1-6	XWHS750-16300	Washer	2	AG
6- 2	TINSEB235WRRZ	Installation instruction	1	AR
6- 3	TINSEB387WRRZ	Operation manual (R-1871TY)	1	AG
6- 3	TINSEB388WRRZ	Operation manual (R-1874TY/R-1875TY)	1	AK
6- 4	TINSKA031WRRZ	Top template	1	AK
6- 5	TINSKA032WRRZ	Wall template	1	AK
6- 6	QW-QZB011MRE0	High voltage wire A	1	AF
6- 7	TCADCB020WRRZ	Cook book	1	AR
6- 8	FW-VZC448WREZ	Main harness (R-1871TY)	1	AZ
6- 8	FW-VZC447WREZ	Main harness (R-1874TY/R-1875TY)	1	BA
6- 9	FAMI-B006MRM0	High rack	1	AU
6-10	FAMI-B005MRM0	Low rack	1	AU
6-11	TCAUAA304WRRZ	User caution label (R-1874TY/R-1875TY)	1	AC
6-12	TCAUAA382WRRZ	Caution label HWC (R-1874TY/R-1875TY)	1	AF
6-13	TCAUAA302WRRZ	DHHS caution label (R-1871TY)	2	AF
6-13	TCAUAA307WRRZ	DHHS caution label (R-1874TY/R-1875TY)	2	AD
6-14	TCAUAA300WRRZ	NHW caution label (R-1871TY)	1	AF
6-14	TCAUAA305WRRZ	NHW caution label (R-1874TY/R-1875TY)	1	AD
6-15	TCAUAA292WRRZ	Monitor caution label (R-1871TY)	1	AF
6-15	TCAUAA366WRRZ	Monitor caution label (R-1874TY/R-1875TY)	1	AF

SCREWS,NUTS AND WASHERS				
7- 1	XHPS740P08K00	Screw	8	AC
7- 2	XOTS740P08000	Screw (R-1871TY)	4	AB
7- 2	XOTS840P08000	Screw (R-1874TY/R-1875TY)	4	AB
7- 3	XHPS730P08000	Screw	5	AC
7- 4	XBTS740P08RV0	Screw	2	AD
7- 5	XCTWW40P08RV0	Screw	2	AB
7- 6	XBTWW40P06000	Screw	2	AA
7- 7	XOTS740P08000	Screw	24	AB
7- 8	XHTS740P08000	Screw	2	AC
7- 9	XHTS740P08RV0	Screw	2	AG
7-10	LX-BZB011MRE0	Unit mounting screw	2	AT
7-11	LX-CZB024MRE0	Hood louver Screws (R-1871TY)	2	AE
7-11	LX-CZB025MRE0	Hood louver Screws (R-1874TY/R-1875TY)	2	AE
7-12	XCBWW30P06000	Screw	8	AB
7-13	LX-CZ0052WRE0	Special screw	2	AA
7-14	XOTWW40P10000	Screw	14	AB
7-15	XEPS730P08XS0	Screw	2	AA

MISCELLANEOUS PARTS

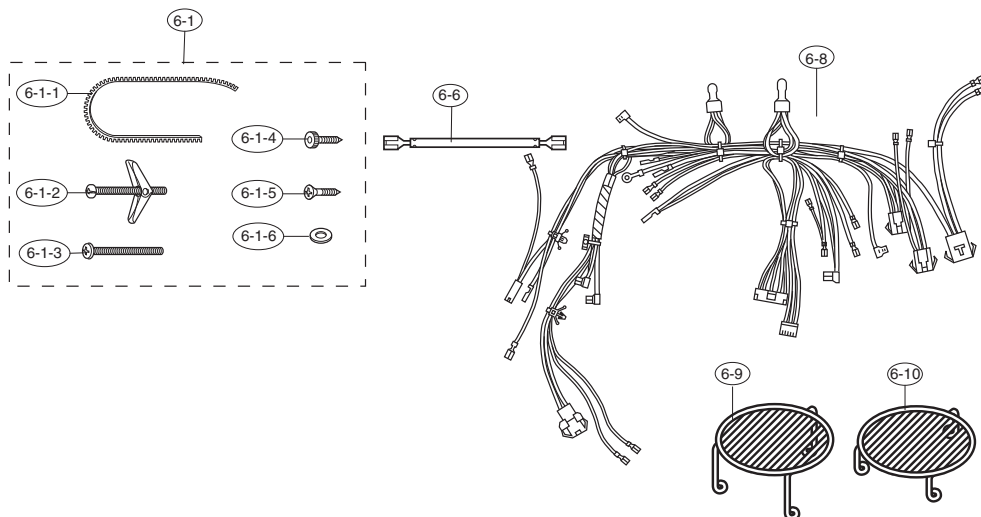

OVEN AND CABINET PARTS

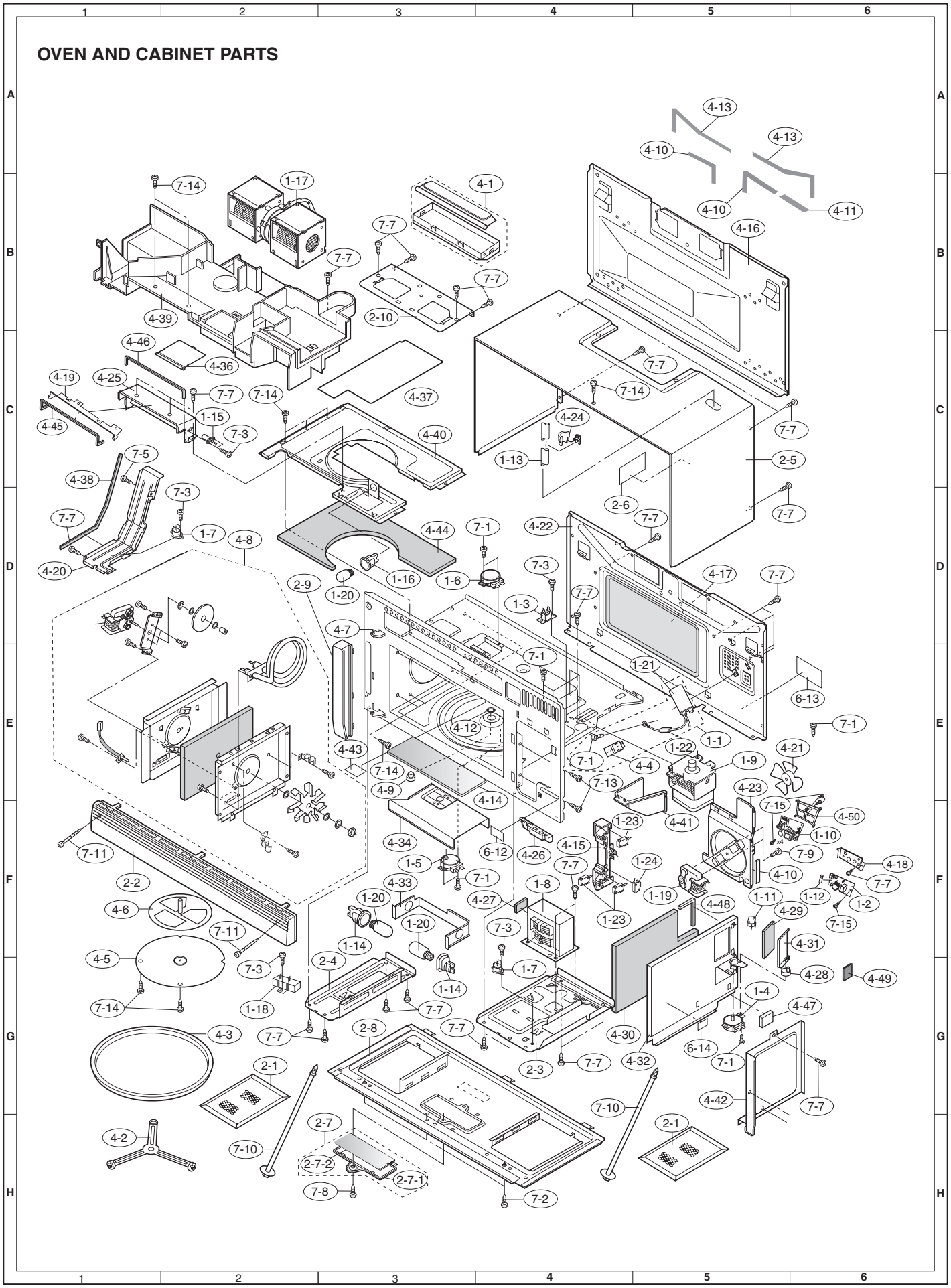

R1871T/ R1875T CONTROL PANEL & DOOR PARTS

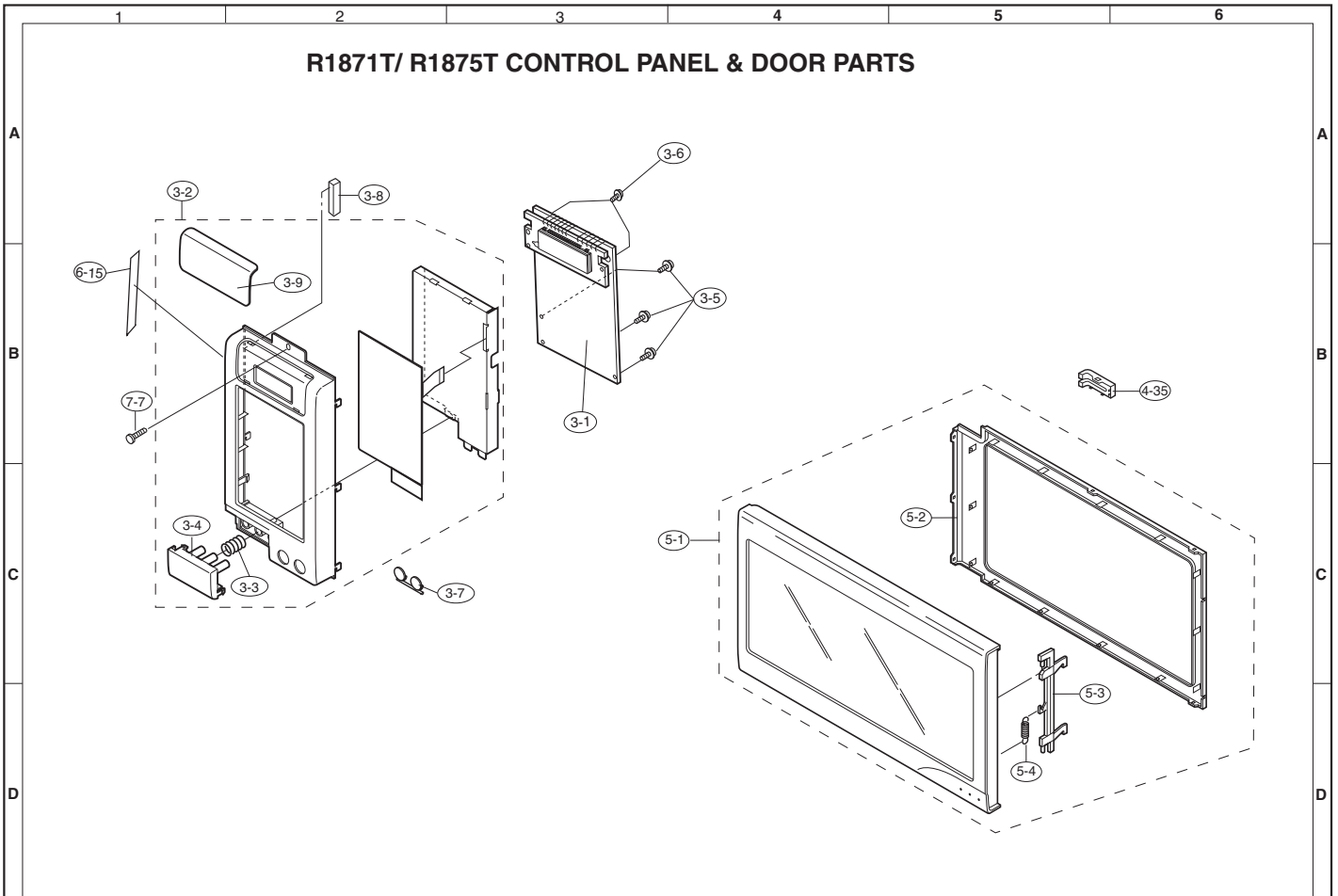

R1874T CONTROL PANEL & DOOR PARTS

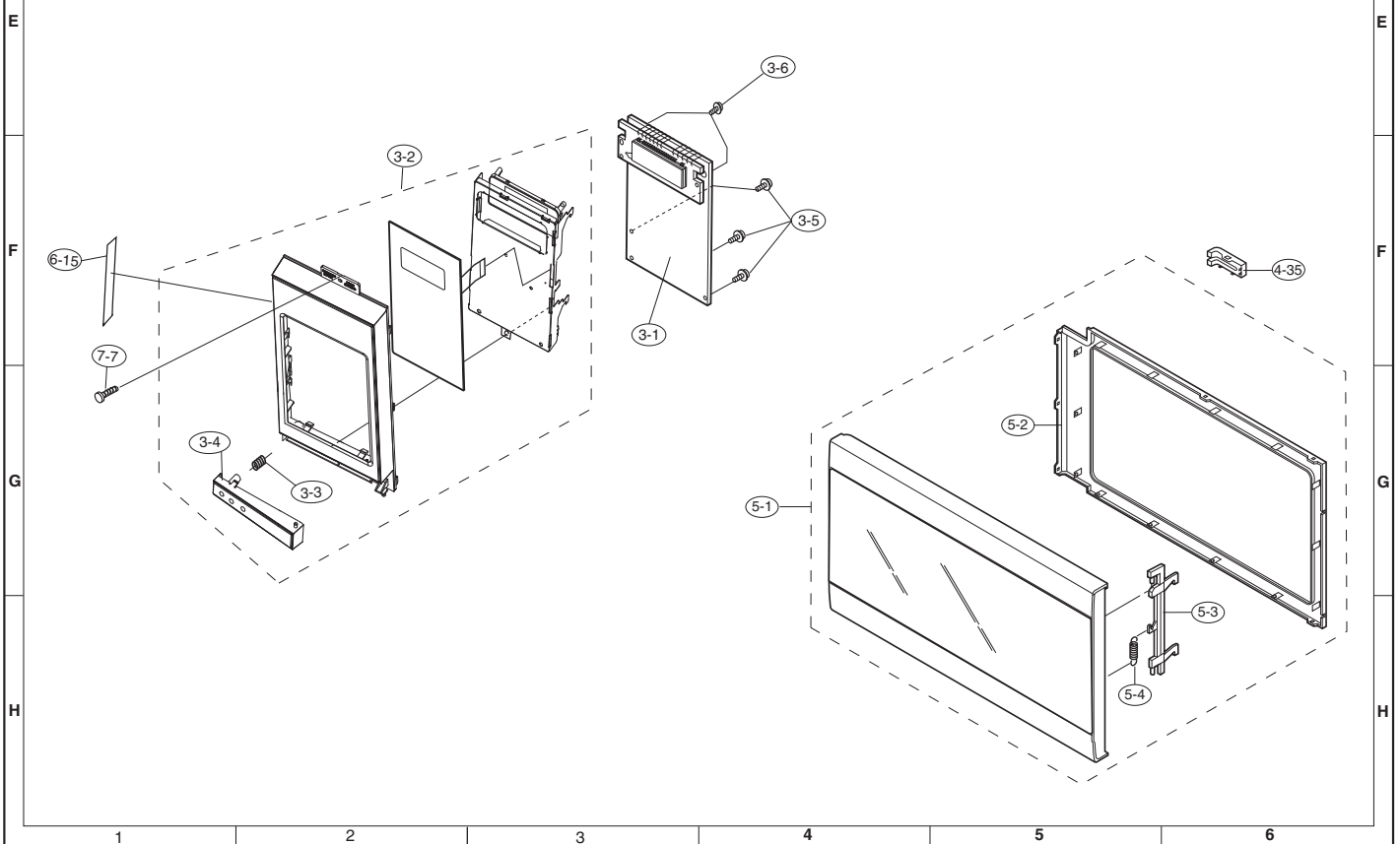

PACKING AND ACCESSORIES

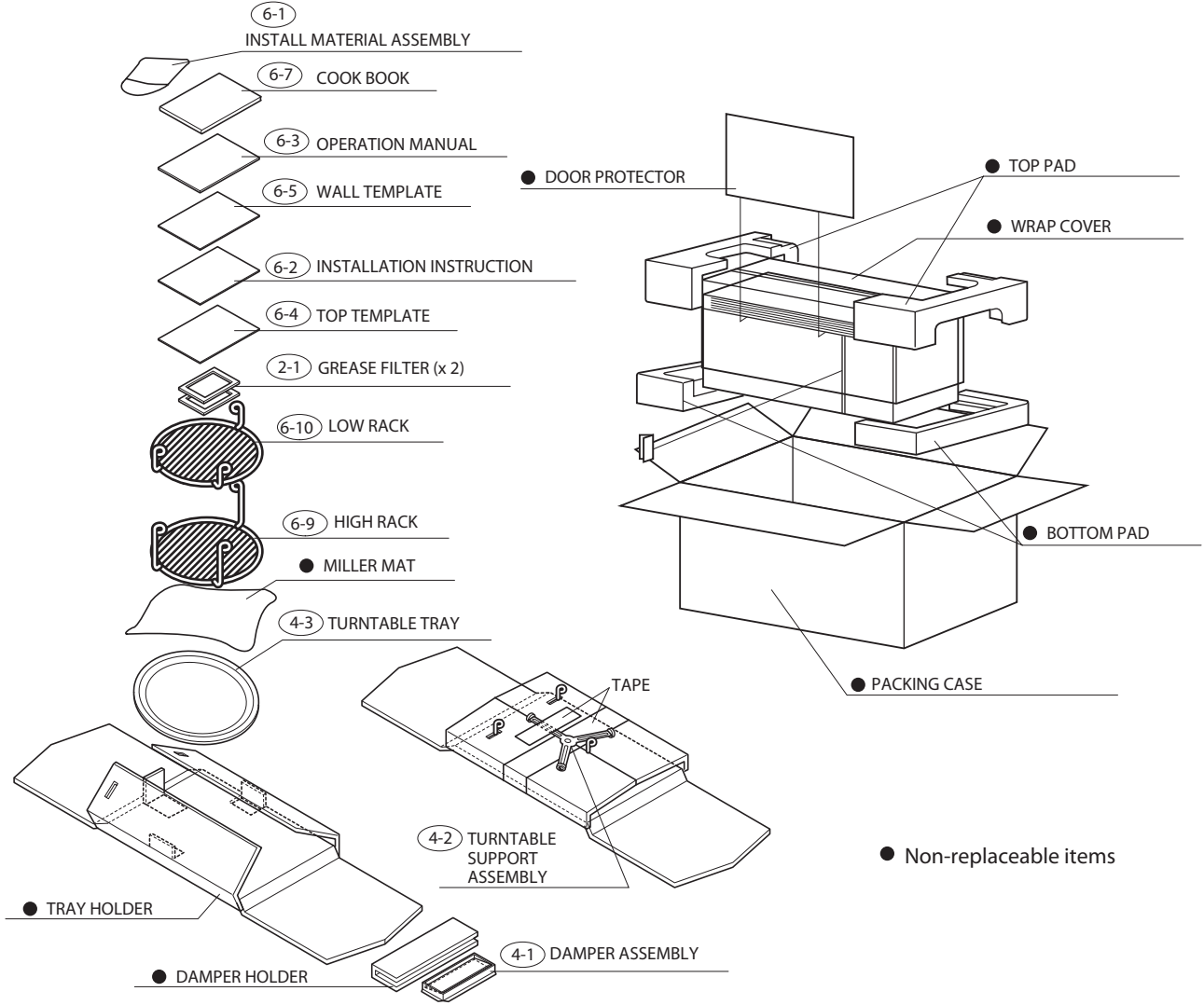

● Non-replaceable items

SHARP

COPYRIGHT © 2016 BY SHARP CORPORATION

ALL RIGHTS RESERVED.

No part of this publication may be reproduced, stored in retrieval systems, or transmitted in any form or by any means, electronic, mechanical, photocopying, recording, or otherwise, without prior written permission of the publisher.