

SHARP SERVICE MANUAL

S9913R930CPST

CONVECTION MICROWAVE OVEN



MODEL **R-930CS**

In the interest of user-safety the oven should be restored to its original condition and only parts identical to those specified should be used.
WARNING TO SERVICE PERSONNEL: Microwave ovens contain circuitry capable of producing very high voltage and current, contact with following parts may result in a severe, possibly fatal, electrical shock. (High Voltage Capacitor, High Voltage Power Transformer, Magnetron, High Voltage Rectifier Assembly, High Voltage Harness etc..)

TABLE OF CONTENTS

	Page
PRECAUTIONS TO BE OBSERVED BEFORE AND DURING SERVICE TO AVOID POSSIBLE EXPOSURE TO EXCESSIVE MICROWAVE ENERGY	INSIDE FRONT COVER
BEFORE SERVICING	INSIDE FRONT COVER
WARNING TO SERVICE PERSONNEL	1
MICROWAVE MEASUREMENT PROCEDURE	2
FOREWORD AND WARNING	3
PRODUCT SPECIFICATIONS	4
GENERAL INFORMATION	4
OPERATION	6
TROUBLESHOOTING GUIDE	12
TEST PROCEDURE	14
TOUCH CONTROL PANEL	25
COMPONENT REPLACEMENT AND ADJUSTMENT PROCEDURE	31
PICTORIAL DIAGRAM	38
CONTROL PANEL CIRCUIT	39
PRINTED WIRING BOARD	40
PARTS LIST	41
PACKING AND ACCESSORIES	44

SHARP CORPORATION

This document has been published to be used for after sales service only.

The contents are subject to change without notice.

PRECAUTIONS TO BE OBSERVED BEFORE AND DURING SERVICING TO AVOID POSSIBLE EXPOSURE TO EXCESSIVE MICROWAVE ENERGY

- (a) Do not operate or allow the oven to be operated with the door open.
- (b) Make the following safety checks on all ovens to be serviced before activating the magnetron or other microwave source, and make repairs as necessary: (1) interlock operation, (2) proper door closing, (3) seal and sealing surfaces (arcing, wear, and other damage), (4) damage to or loosening of hinges and latches, (5) evidence of dropping or abuse.
- (c) Before turning on microwave power for any service test or inspection within the microwave generating compartments, check the magnetron, wave guide or transmission line, and cavity for proper alignment, integrity, and connections.
- (d) Any defective or misadjusted components in the interlock, monitor, door seal, and microwave generation and transmission systems shall be repaired, replaced, or adjusted by procedures described in this manual before the oven is released to the owner.
- (e) A microwave leakage check to verify compliance with the Federal Performance Standard should be performed on each oven prior to release to the owner.

BEFORE SERVICING

Before servicing an operative unit, perform a microwave emission check as per the Microwave Measurement Procedure outlined in this service manual.

If microwave emissions level is in excess of the specified limit, contact SHARP ELECTRONICS CORPORATION immediately @1-800-237-4277.

If the unit operates with the door open, service person should 1) tell the user not to operate the oven and 2) contact SHARP ELECTRONICS CORPORATION and Food and Drug Administration's Center for Devices and Radiological Health immediately.

Service personnel should inform SHARP ELECTRONICS CORPORATION of any certified unit found with emissions in excess of $4\text{mW}/\text{cm}^2$. The owner of the unit should be instructed not to use the unit until the oven has been brought into compliance.

WARNING TO SERVICE PERSONNEL

Microwave ovens contain circuitry capable of producing very high voltage and current, contact with following parts may result in a severe, possibly fatal, electrical shock.

(Example)

High Voltage Capacitor, High Voltage Power Transformer, Magnetron, High Voltage Rectifier Assembly, High Voltage Harness etc..

Read the Service Manual carefully and follow all instructions.

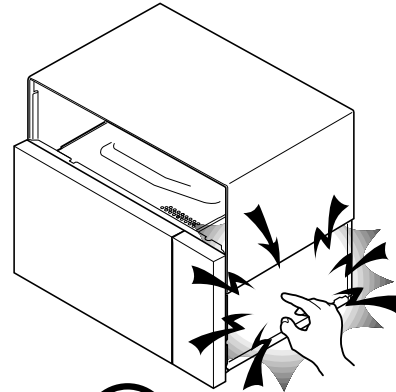

**Don't Touch !
Danger High Voltage**

Before Servicing



1. Disconnect the power supply cord , and then remove outer case.
2. Open the door and block it open.
3. Discharge high voltage capacitor.

WARNING: RISK OF ELECTRIC SHOCK. DISCHARGE THE HIGH-VOLTAGE CAPACITOR BEFORE SERVICING.

The high-voltage capacitor remains charged about 60 seconds after the oven has been switched off. Wait for 60 seconds and then short-circuit the connection of the high-voltage capacitor (that is the connecting lead of the high-voltage rectifier) against the chassis with the use of an insulated screwdriver.

Whenever troubleshooting is performed the power supply must be disconnected. It may, in some cases, be necessary to connect the power supply after the outer case has been removed, in this event,

1. Disconnect the power supply cord, and then remove outer case.
2. Open the door and block it open.
3. Discharge high voltage capacitor.
4. Disconnect the leads to the primary of the power transformer.
5. Ensure that the leads remain isolated from other components and oven chassis by using insulation tape.
6. After that procedure, reconnect the power supply cord.

When the testing is completed,

1. Disconnect the power supply cord, and then remove outer case.
2. Open the door and block it open.
3. Discharge high voltage capacitor.
4. Reconnect the leads to the primary of the power transformer.
5. Reinstall the outer case (cabinet).
6. Reconnect the power supply cord after the outer case is installed.
7. Run the oven and check all functions.

After repairing

1. Reconnect all leads removed from components during testing.
2. Reinstall the outer case (cabinet).
3. Reconnect the power supply cord after the outer case is installed.
4. Run the oven and check all functions.

Microwave ovens should not be run empty. To test for the presence of microwave energy within a cavity, place a cup of cold water on the oven turntable, close the door and set the power to HIGH and set the microwave timer for two (2) minutes. When the two minutes has elapsed (timer at zero) carefully check that the water is now hot. If the water remains cold carry out **Before Servicing** procedure and re-examine the connections to the component being tested.

When all service work is completed and the oven is fully assembled, the microwave power output should be checked and a microwave leakage test should be carried out.

MICROWAVE MEASUREMENT PROCEDURE

A. Requirements:

- 1) Microwave leakage limit (Power density limit): The power density of microwave radiation emitted by a microwave oven should not exceed 1 mW/cm^2 at any point 5cm or more from the external surface of the oven, measured prior to acquisition by a purchaser, and thereafter (through the useful life of the oven), 5 mW/cm^2 at any point 5cm or more from the external surface of the oven.
- 2) Safety interlock switches Primary interlock relay and door sensing switch shall prevent microwave radiation emission in excess of the requirement as above mentioned, secondary interlock switch shall prevent microwave radiation emission in excess of 5 mW/cm^2 at any point 5cm or more from the external surface of the oven.

B. Preparation for testing:

Before beginning the actual measurement of leakage, proceed as follows:

- 1) Make sure that the actual instrument is operating normally as specified in its instruction booklet.

Important:

Survey instruments that comply with the requirement for instrumentation as prescribed by the performance standard for microwave ovens, 21 CFR 1030.10(c)(3)(i), must be used for testing.

- 2) Place the oven tray in the oven cavity.
- 3) Place the load of $275 \pm 15 \text{ ml}$ (9.8 oz) of tap water initially at $20 \pm 5^\circ \text{C}$ (68°F) in the center of the oven cavity.
The water container shall be a low form of 600 ml (20 oz) beaker with an inside diameter of approx. 8.5 cm (3-1/2 in.) and made of an electrically nonconductive material such as glass or plastic.
The placing of this standard load in the oven is important not only to protect the oven, but also to insure that any leakage is measured accurately.
- 4) Set the cooking control on Full Power Cooking Mode.
- 5) Close the door and select a cook cycle of several minutes. If the water begins to boil before the survey is completed, replace it with 275 ml of cool water.

C. Leakage test:

Closed-door leakage test (microwave measurement)

- 1) Grasp the probe of the survey instrument and hold it perpendicular to the gap between the door and the body of the oven.
- 2) Move the probe slowly, not faster than 1 in./sec. (2.5 cm/sec.) along the gap, watching for the maximum indication on the meter.
- 3) Check for leakage at the door screen, sheet metal seams and other accessible positions where the continuity of the metal has been breached (eg., around the switches, indicator, and vents).
While testing for leakage around the door pull the door away from the front of the oven as far as is permitted by the closed latch assembly.
- 4) Measure carefully at the point of highest leakage and make sure that the highest leakage is no greater than 4 mW/cm^2 , and that the secondary interlock switch does turn the oven OFF before any door movement.

NOTE: After servicing, record data on service invoice and microwave leakage report.

SERVICE MANUAL

SHARP

CONVECTION
MICROWAVE OVEN

R-930CS

FOREWORD

This Manual has been prepared to provide Sharp Electronics Corp. Service Personnel with Operation and Service Information for the SHARP CONVECTION MICROWAVE OVEN, R-930CS.

It is recommended that service personnel carefully study the entire text of this manual so that they will be qualified to render satisfactory customer service.

Check the interlock switches and the door seal carefully. Special attention should be given to avoid electrical shock and microwave radiation hazard.

WARNING

Never operate the oven until the following points are ensured.

- (A) The door is tightly closed.
- (B) The door brackets and hinges are not defective.
- (C) The door packing is not damaged.
- (D) The door is not deformed or warped.
- (E) There is no other visible damage with the oven.

Servicing and repair work must be carried out only by trained service personnel.

DANGER

Certain initial parts are intentionally not grounded and present a risk of electrical shock only during servicing. Service personnel - Do not contact the following parts while the appliance is energized;

**High Voltage Capacitor, Power Transformer, Magnetron, High Voltage Rectifier Assembly, High Voltage Harness;
If provided, Vent Hood, Fan assembly, Cooling Fan Motor.**

All the parts marked "*" on parts list are used at voltages more than 250V.

Removal of the outer wrap gives access to voltage above 250V.

All the parts marked "Δ" on parts list may cause undue microwave exposure, by themselves, or when they are damaged, loosened or removed.

SHARP ELECTRONICS CORPORATION

SHARP PLAZA, MAHWAH,
NEW JERSEY 07430-2135

PRODUCT DESCRIPTION

GENERAL INFORMATION

OPERATION

TROUBLESHOOTING GUIDE
AND TEST PROCEDURE

TOUCH CONTROL PANEL

COMPONENT REPLACEMENT AND
ADJUSTMENT PROCEDURE

WIRING DIAGRAM

PARTS LIST

SPECIFICATION

ITEM	DESCRIPTION
Power Requirements	120 Volts 13.0 Amperes (Microwave) / 13.0 Amperes (Convection) 60 Hertz / Single phase, 3 wire grounded
Power Output	900 watts (IEC 705 Test Procedure) Operating frequency of 2450MHz
Convection Power Output	1450 Watts
Case Dimensions	Width 24-5/8" Height 14-7/8" Depth 19"
Cooking Cavity Dimensions (1.5 Cubic Feet)	Width 16-1/8" Height 9-5/8" Depth 16-1/8"
Control Complement	<p>Touch Control System</p> <p>Timer (0 - 99 min. 99 seconds)</p> <p>Microwave Power for Variable Cooking</p> <p>Repetition Rate;</p> <p style="padding-left: 40px;">P-HI Full power throughout the cooking time</p> <p style="padding-left: 40px;">P-90 approx. 90% of Full Power</p> <p style="padding-left: 40px;">P-80 approx. 80% of Full Power</p> <p style="padding-left: 40px;">P-70 approx. 70% of Full Power</p> <p style="padding-left: 40px;">P-60 approx. 60% of Full Power</p> <p style="padding-left: 40px;">P-50 approx. 50% of Full Power</p> <p style="padding-left: 40px;">P-40 approx. 40% of Full Power</p> <p style="padding-left: 40px;">P-30 approx. 30% of Full Power</p> <p style="padding-left: 40px;">P-20 approx. 20% of Full Power</p> <p style="padding-left: 40px;">P-10 approx. 10% of Full Power</p> <p style="padding-left: 40px;">P-0 No power throughout the cooking time</p> <p>Convection Temperature for Variable Cooking</p> <p style="padding-left: 40px;">CONVECTION 100 - 450°F Temp. control</p> <p style="padding-left: 40px;">LOW MIX. BAKE 350°F with 10% microwave power</p> <p style="padding-left: 40px;">HIGH MIX. ROAST 300°F with 30% microwave power</p> <p style="padding-left: 40px;">SLOW COOK 300°F for 4 hours (no preheat)</p> <p style="padding-left: 40px;">BROIL 450°F (preheat)</p> <p>CUSTOM HELP pad, SENSOR REHEAT pad, MINUTE PLUS pad, POPCORN pad COMPU DEFROST pad, SENSOR COOK pad, COMPU BROIL pad COMPU ROAST pad, COMPU BAKE pad, REHEAT pad, CONVEC pad BROIL pad, SLOW COOK pad, HIGH MIX / ROAST pad, LOW MIX / BAKE pad Number and temperature selection pads, KITCHEN TIMER pad, CLOCK pad STOP/CLEAR pad, POWER LEVEL pad, START / TOUCH ON pad</p>
Oven Cavity Light	Yes
Safety Standard	UL Listed FCC Authorized DHHS Rules, CFR, Title 21, Chapter 1, Subchapter J

GENERAL INFORMATION

GROUNDING INSTRUCTIONS

This oven is equipped with a three prong grounding plug. It must be plugged into a wall receptacle that is properly installed and grounded in accordance with the National Electrical Code and local codes and ordinances.

In the event of an electrical short circuit, grounding reduces the risk of electric shock by providing an escape wire for the electric current.

WARNING: Improper use of the grounding plug can result in a risk of electric shock.

Electrical Requirements

The electrical requirements are a 115 -120 volt 60 Hz, AC only, 15 or 20 amp. fused electrical supply. It is recommended that a separate circuit serving only this appliance be provided. When installing this appliance, observe all applicable codes and ordinances.

A short power-supply cord is provided to reduce risks of becoming entangled in or tripping over a longer cord.

Where a two-pronged wall-receptacle is encountered, it is the personal responsibility and obligation of the customer to contact a qualified electrician and have it replaced with a properly grounded three-pronged wall receptacle or have a grounding adapter properly grounded and polarized. If an extension cord must be used, it should be a 3-wire, 15 amp. or more cord. Do not drape over a countertop or table where it can be pulled on by children or tripped over accidentally.

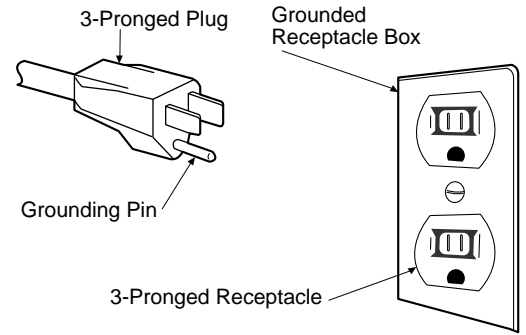

CAUTION: DO NOT UNDER ANY CIRCUMSTANCES CUT OR REMOVE THE ROUND GROUNDING PRONG FROM THIS PLUG.

OVEN DIAGRAM

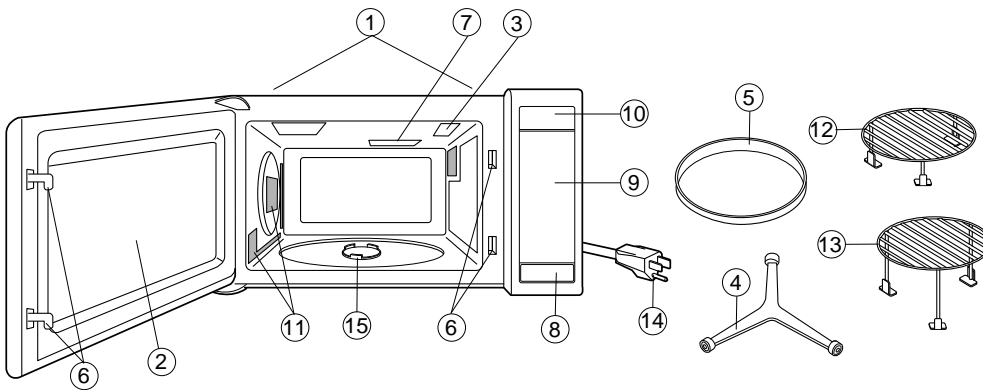

1. Ventilation openings. (Rear side)
2. Oven door with see-through window.
3. Oven lamp.
4. Turntable support.
5. Removable turntable.
The turntable will rotate clockwise or counterclockwise.
6. Safety door latches.
The oven will not operate unless the door is securely closed.
7. Wave guide cover.
8. Door open button.
9. Auto-Touch control panel.
10. Lighted digital display.
11. Convection air openings.
12. Removable low rack. (Broiling trivet)
13. Removable low rack. (Baking rack)
14. Power supply cord.
15. Turntable motor shaft.

TOUCH CONTROL PANEL

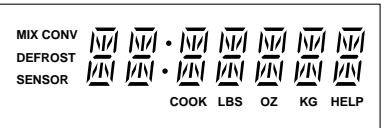

Interactive Custom Help

Sensor Reheat Minute Plus

Popcorn Elevate PKG Compu Defrost

1 Baked potatoes
2 Frozen vegetables
3 Fresh veg-soft
4 Fresh veg-hard
5 Frozen entrees
6 Hot dogs
7 Bacon
8 Fish, seafood

Sensor Cook

Convection

1 Hamburgers
2 Chicken pieces
3 Steaks
4 Fish steaks

Compu Broil

1 Chicken
2 Turkey
3 Turkey breast
4 Pork

Compu Roast

1 Bundt cake
2 Cookies
3 Muffins
4 French fries

Compu Bake

Preheat | Convec | Broil

Slow Cook | Low Mix Bake | High Mix Roast

1 100°F	2 150°F	3 275°F	4 300°F	5 325°F
6 350°F	7 375°F	8 400°F	9 425°F	0 450°F

Kitchen Timer | Clock | Stop Clear

Power Level | Start Touch On

OPERATION

DESCRIPTION OF OPERATING SEQUENCE

The following is a description of component functions during oven operation.

OFF CONDITION

Closing the door activates the door sensing switch and secondary interlock switch. (In this condition, the monitor switch contacts are opened.)

When oven is plugged in, 120 volts A.C. is supplied to the control unit. (Figure O-1).

1. The display will show "SHARP SIMPLY THE BEST PRESS CLEAR AND PRESS CLOCK".

To set any program or set the clock, you must first touch the STOP/CLEAR pad. The display will clear, and " : " will appear.

NOTE: When the door is opened, the oven lamp comes on.

2. A signal is input to the control unit, energizing the coil of shut-off relay (RY-4). RY4 contacts close, completing a circuit to the damper motor. The damper motor now operates moving the damper to the open position, thereby closing the contacts of the damper switch inputs a signal to the control unit. The coil of relay RY-4 is de-energized, opening its contacts, thereby turning off the damper motor.

COOKING CONDITION

Program desired cooking time Variable Cooking Control by touching the NUMBER pads and the power level pad. When the START pad is touched, the following operations occur:

1. The contacts of relays are closed and components connected to the relays are turned on as follows.
(For details, refer to Figure O-2)

RELAY	CONNECTED COMPONENTS
RY-1	Oven lamp/Turntable motor
RY-2	Power transformer
RY-3	Heating element
RY-4	Damper motor
RY-5	Convection motor
RY-6	Fan motor

2. 120 volts A.C. is supplied to the primary winding of the power transformer and is converted to about 3 volts A.C. output on the filament winding, and approximately 2360 volts A.C. on the high voltage winding.
3. The filament winding voltage heats the magnetron filament and the H.V. winding voltage is sent to a voltage doubler circuit.
4. The microwave energy produced by the magnetron is channelled through the waveguide into the cavity feed-box, and then into the cavity where the food is placed to be cooked.
5. Upon completion of the cooking time, the power transformer, oven lamp, etc. are turned off, and the generation of microwave energy is stopped. The oven will revert to the OFF condition.
6. When the door is opened during a cook cycle, monitor switch, door sensing switch, the primary interlock relay

and the secondary interlock switch are activated with the following results. The circuits to the turntable motor, the cooling fan motor, and the high voltage components are de-energized, the oven lamp remains on, and the digital read-out displays the time still remaining in the cook cycle when the door was opened.

7. The monitor switch is electrically monitoring the operation of the primary interlock relay and the secondary interlock switch and is mechanically associated with the door so that it will function in the following sequence.

- (1) When the door opens from a closed position, the primary interlock relay and the secondary interlock switch open their contacts, and then the monitor switch contacts close.
- (2) When the door is closed from the open position, the monitor switch contacts first open, and then the contacts of the primary interlock relay and the secondary interlock switch close.

If the primary interlock relay and the secondary interlock switch fail with their contacts closed when the door is opened, the closing of the monitor switch contacts will form a short circuit through the monitor fuse, primary interlock relay and the secondary interlock switch, causing the monitor fuse to blow.

POWER LEVEL P-0 TO P-90 COOKING

When Variable Cooking Power is programmed, the 120 volts A.C. is supplied to the power transformer intermittently through the contacts of relay (RY-2). RY-2 is operated by the control unit within a varying time base. Microwave power operation is as follows:

VARI-MODE	ON TIME	OFF TIME
Power 10(P-HI) (100% power)	32 sec.	0 sec.
Power 9(P-90) (approx. 90% power)	30 sec.	2 sec.
Power 8(P-80) (approx. 80% power)	26 sec.	6 sec.
Power 7(P-70) (approx. 70% power)	24 sec.	8 sec.
Power 6(P-60) (approx. 60% power)	22 sec.	10 sec.
Power 5(P-50) (approx. 50% power)	18 sec.	14 sec.
Power 4(P-40) (approx. 40% power)	16 sec.	16 sec.
Power 3(P-30) (approx. 30% power)	12 sec.	20 sec.
Power 2(P-20) (approx. 20% power)	8 sec.	24 sec.
Power 1(P-10)(approx. 10% power)	6 sec.	26 sec.
Power 0(P-0) (0% power)	0 sec.	32 sec.

Note: The ON/OFF time ratio does not correspond with the percentage of microwave power, because approx. 2 seconds are needed for heating of the magnetron filament.

CONVECTION COOKING CONDITION

PREHEATING CONDITION

Program desired convection temperature by touching the CONVECTION pad and the Temperature pad. When the START pad is touched, the following operations occur:

1. The coil of shut-off relays (RY1, RY3, RY5 and RY6) are energized, the oven lamp, cooling fan motor, turntable

- motor and convection motor are turned on.
- The coil of relay (RY4) is energized by the control unit. The damper is moved to the closed position, opening the damper switch contacts. The opening of the damper switch contacts sends a signal to the LSI on the control unit de-energizing the relay (RY4) and opening the circuit to the damper motor.
 - The coil of heater relay (RY3) is energized by the control unit and the main supply voltage is applied to the heating element.
 - When the oven temperature reaches the selected preheat temperature, the following operations occur:
 - 4-1 The heater relay is de-energized by the control unit temperature circuit and thermistor, opening the circuit to the heating element.
 - 4-2. The oven will continue to function for 30 minutes, turning the heater on and off, as needed to maintain the selected preheat temperature. The oven will shut-down completely after 30 minutes

CONVECTION COOKING CONDITION

When the preheat temperature is reached, a beep signal will sound indicating that the holding temperature has been reached in the oven cavity. Open the door and place the food to be cooked in the oven. Touch the CONVEC pad first and then touch the Temperature pad. And program desired cooking time by touching the Number pads. When the START pad is touched, the following operations occur:

- The numbers on the digital read-out start to count down to zero.
- The oven lamp, turntable motor, cooling fan motor and convection motor are energized.
- Heater relay (RY3) is energized (if the cavity temperature is lower than the selected temperature) and the main supply voltage is applied to the heating element to return to the selected cooking temperature.
- Upon completion of the cooking time, the audible signal will sound, and oven lamp, turntable motor, cooling fan motor and convection motor are de-energized. At the end of the convection cycle, if the cavity air temperature is above 275°F, the circuit to RY6 will be maintained (by the thermistor circuit) to continue operation of the cooling fan motor until the temperature drops below 245°F, at which time the relay will be de-energized, turning off the fan motor. Relay RY5 will however, open as soon as the convection cycle has ended, turning off the convection fan motor.
- At the end of the convection cook cycle, shut-off relay (RY4) is energized turning on the damper motor. The damper is returned to the open position, closing the damper switch contacts which send a signal to the control unit, de-energizing shut-off relay (RY4).

AUTOMATIC MIX COOKING CONDITION

Touch the HIGH MIX/ROAST or the LOW MIX/BAKE pad first. And then program desired cooking time by touching the Number pads. The LOW MIX/BAKE pad is preprogrammed for 350°F with 10% microwave power, while the HIGH MIX/ROAST pad is preprogrammed for 300°F with 30% microwave power. When the START pad is touched, the following operations occur:

- The numbers on the digital read-out start to count down

to zero.

- The shut-off relays (RY1,RY2,RY3,RY5 and RY6) are energized, turning on the oven lamp, turntable motor, cooling fan motor and convection fan motor.
- The shut-off relay (RY4) is energized. The damper door is closed from the open position.
- The heater relay (RY3) is energized, applying the main supply voltage to the heating element.
- Now, the oven is in the convection cooking condition.
- When the oven temperature reaches the selected temperature, the following operations occur:
 - 6-1. The power supply voltage is alternated to the heating element and power transformer.
 - 6-2. The heating element operates through the heater relay (RY3) contacts and the power transformer operates through the primary interlock relay (RY2) contacts.
 - 6-3. These are operated by the control unit to supply alternately within a 32 second time base, convection heat and microwave energy.

The relationship between the convection and microwave power operations are as follows.

Note: The ON and OFF time ratio does not correspond with the percentage of microwave power, because approx. 2 seconds are needed for heating of the magnetron filament.

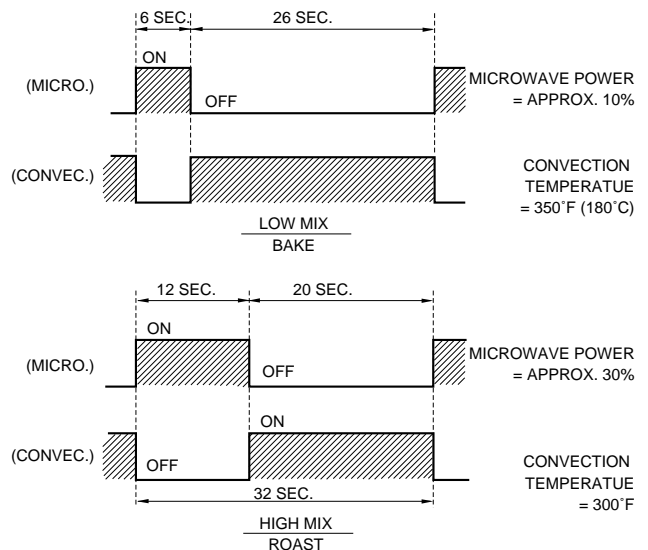

Note: During alternate Microwave/Convection operation, the convection heater is energized only if the cavity temperature drops below the set temperature.

SENSOR COOKING CONDITION

Using the SENSOR COOK function, the foods are cooked without figuring time, power level or quantity. When the oven senses enough steam from the food, it relays the information to its microprocessor which will calculate the remaining cooking time and power level needed for best results. When the food is cooked, water vapor is developed. The sensor "senses" the vapor and its resistance increases gradually. When the resistance reaches the value set according to the menu, supplementary cooking is started. The time of supplementary cooking is determined by experiment with each food category and inputted into the LSI.

An example of how sensor works:

1. Potatoes at room temperature. Vapor is emitted very slowly.



2. Heat potatoes. Moisture and humidity is emitted rapidly. You can smell the aroma as it cooks.

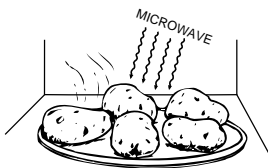

3. Sensor detects moisture and humidity and calculates cooking time and variable power.

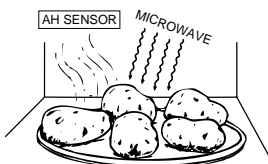

Cooking Sequence.

1. Touch SENSOR COOK pad.

NOTE: The oven should not be operated on SENSOR COOK immediately after plugging in the unit. Wait two minutes before cooking on SENSOR COOK.

2. Select desired Sensor setting.

3. Touch START pad.

The coil of shut-off relay (RY1, RY6) is energized, the oven lamp and cooling fan motor are turned on, but the power transformer is not turned on.

4. After about 16 seconds, the cook relay (RY-2) is energized. The power transformer is turned on, microwave energy is produced and first stage is started. The 16 seconds is the cooling time required to remove any vapor from the oven cavity and sensor.

NOTE: During this first stage, do not open the door or touch STOP/CLEAR pad.

5. When the sensor detects the vapor emitted from the food, the display switches over to the remaining cooking time and the timer counts down to zero. At this time, the door may be opened to stir food, turn it or season, etc.

6. When the timer reaches zero, an audible signal sounds. The shut-off relay and cook relay are de-energized and the power transformer, oven lamp, etc. are turned off.

7. Opening the door or touching the STOP/CLEAR pad, the time of day will reappear on the display and the oven will revert to an OFF condition.

COMPU BROIL/ COMPU ROAST/ COMPU BAKE

COMPU BROIL/ ROAST/ BAKE will automatically compute the oven temperature, microwave power and cooking time for baking, roasting and broiling. Set the desired program by touching the COMPU BROIL/ ROAST/ BAKE pad, and number pad. Enter the weight by touching the Number pads. When the START pad is touched, the following operations occur:

1. The COOK indicator will light and the Convection Fan Symbol will rotate.

2. The cooking time will appear on the display and start counting down to zero. The cooking time is adjusted automatically according to the weight of the food.

3. The shut-off relays (RY1, RY5 and RY6) are energized, turning on the oven lamp, turntable motor, cooling fan motor and convection motor. The power supply voltage is applied to the heating element.

4. Now, the oven is in the convection cooking mode.

5. When the oven temperature has reached the programmed

convection temperature, the oven goes into the programmed cooking mode.

6. At the end of the COMPU BROIL/ ROAST/ BAKE cycle, the damper is returned to the open position and the oven will go to the off condition. The cooling fan will remain on until the oven has cooled.

COMPU DEFROST COOKING

The COMPU DEFROST key is a special function key to defrost meats and poultry faster and better. COMPU DEFROST automatically defrosts roast beef, etc.. When the COMPU DEFROST is selected and the food weight is entered by using the COMPU DEFROST pad, the oven will cook according to the special cooking sequence.

FIRE SENSING FEATURE (MICROWAVE MODE)

This model incorporates a sensing feature which will stop the oven's operation if there is a fire in the oven cavity during microwave cooking. This is accomplished by the LSI repeatedly measuring the voltage across the temperature measurement circuit (thermistor) during its 32-seconds time base comparing the obtained voltage measurements. If the most recent voltage measured is 300mV greater than the previous voltage measured, the LSI judges it as a fire in the oven cavity and switches off the relays to the power transformer, fan motor and convection motor. The LSI also stops counting down and closes the damper door so that no fresh air will enter the oven cavity. Please refer to the following section for a more detailed description.

Operation

Please refer to the timing diagrams below.

- The thermistor operates within a 32-seconds time base and it is energized for three (3) seconds and off for 29 seconds. Two (2) seconds after the thermistor is energized, the voltage across the temperature measurement circuit is sampled by the LSI and twenty one (21) seconds after the thermistor is cut off the LSI turns on the cooling fan for six (6) seconds.
- The above procedure is repeated. If the difference between the first voltage measured (in step 1) and the voltage measured when the procedure is repeated (step 2) is greater than 300mV the LSI makes the judgment that there is a fire in the oven cavity and will switch off the relays to the power transformer, fan motor and convection motor. The LSI also stops counting down and closes the damper door so that no fresh air will enter the oven cavity.
- Once the fire sensor feature has shut the unit down, the programmed cooking cycle may be resumed by pressing the "START" pad or the unit may be reset by pressing the "CLEAR" pad.

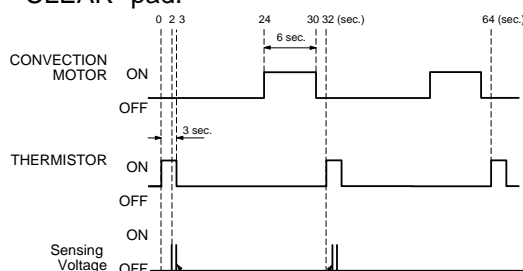

Sensing the voltage across the temperature measurement circuit.

IMPORTANT:
 During sensor cooking operation, the fire sensing operation sequence will not begin until the AH sensor has

detected vapors and initiated a sensor cooking cycle. This is because the operation of the convection fan would interfere with the AH sensor's vapor detection.

SCHEMATIC DIAGRAM

SCHEMATIC
 NOTE: CONDITION OF OVEN
 1. DOOR CLOSED.
 2. CLOCK APPEARS ON DISPLAY.

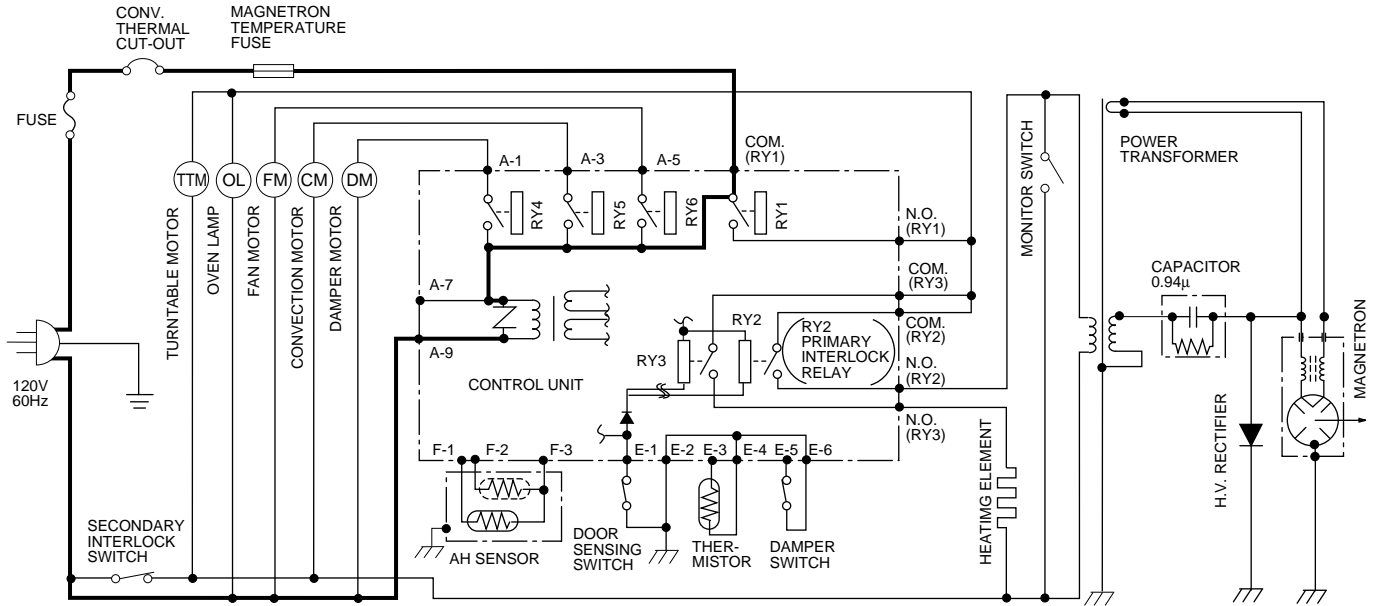

Figure O-1. Oven Schematic-OFF Condition

SCHEMATIC
 1. DOOR CLOSED.
 2. COOKING TIME PROGRAMMED.
 3. "START" PAD TOUCHED.

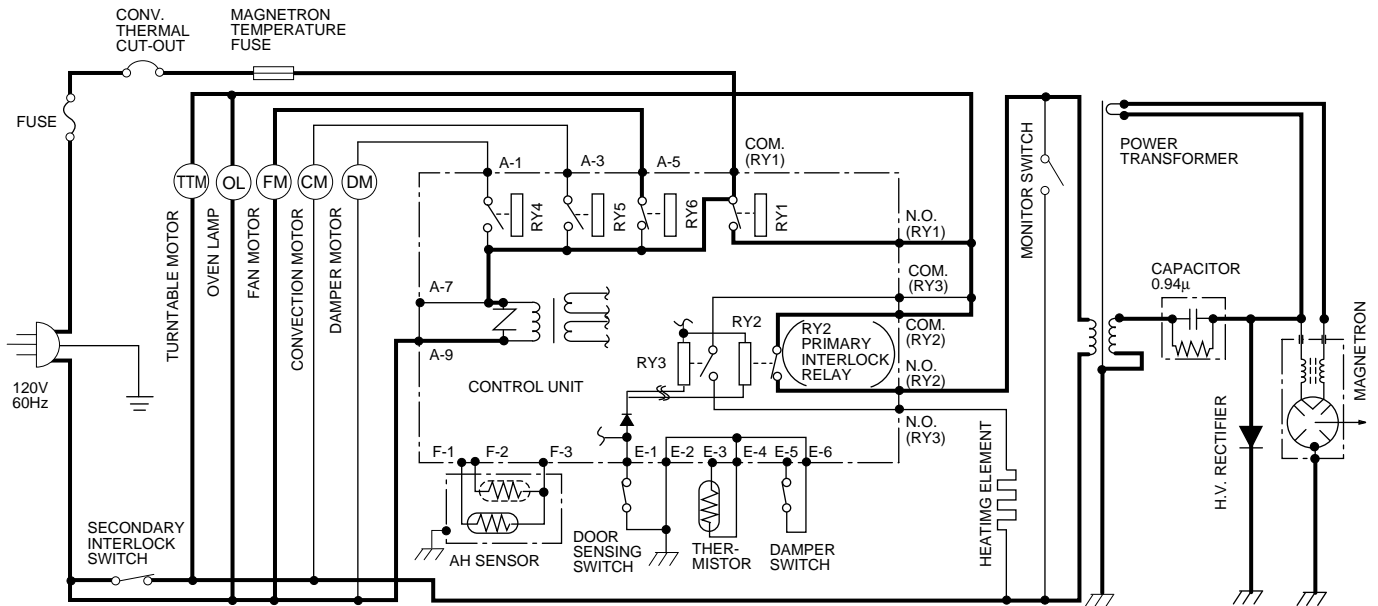

Figure O-2. Oven Schematic-Microwave Cooking Condition

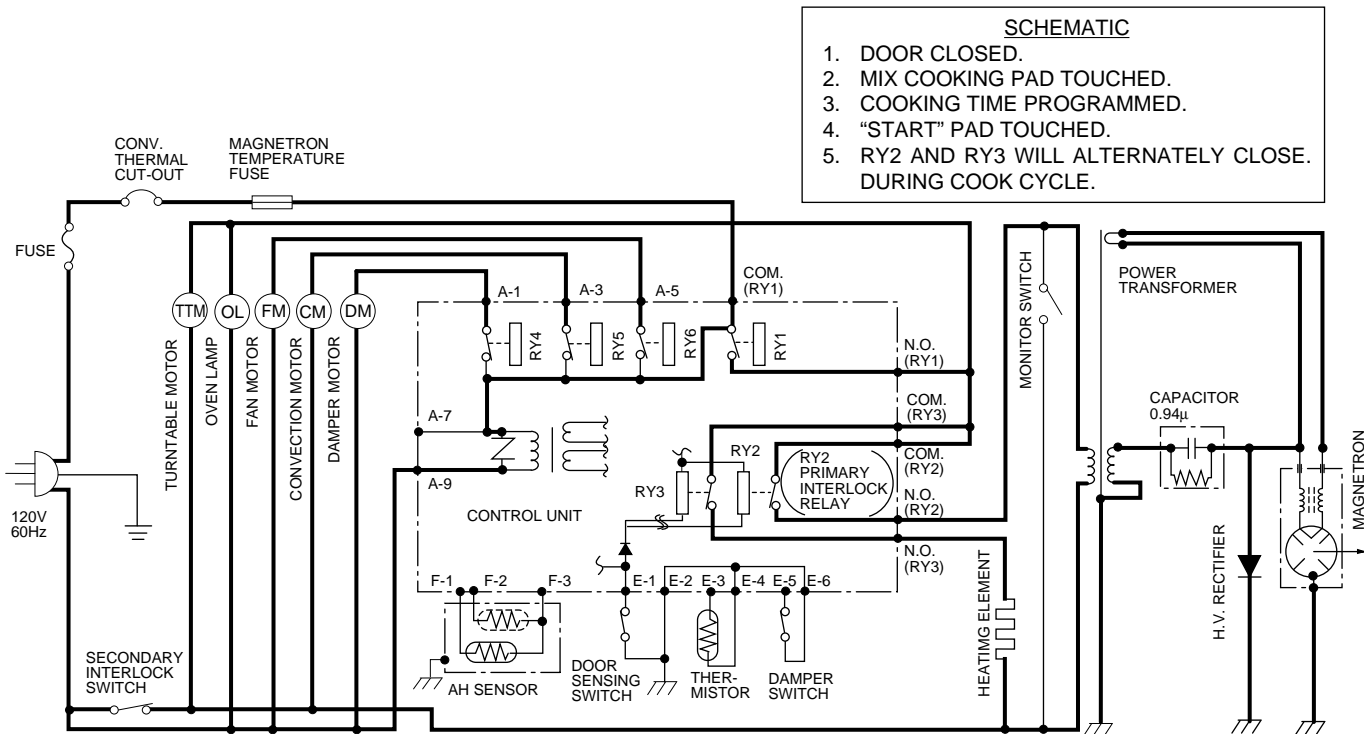

Figure O-3. Oven Schematic-Automatic Mix Cooking Condition

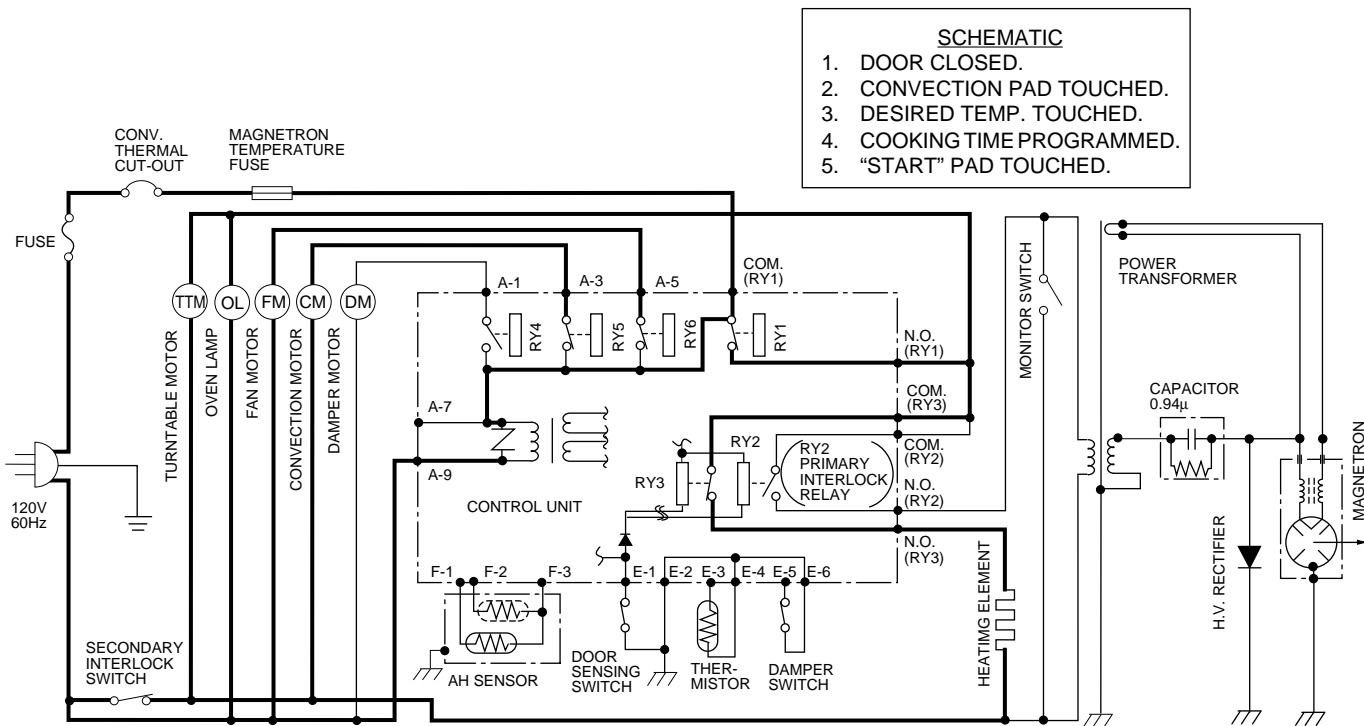

Figure O-4. Oven Schematic-Convection Cooking Condition

DESCRIPTION AND FUNCTION OF COMPONENTS

DOOR SENSING AND SECONDARY INTERLOCK SWITCHES

The door sensing switch in the primary interlock system is mounted in the upper position on the latch hook, the second-

ary interlock switch is mounted in the lower position on the latch hook. They are activated by the latch heads on the door. When the door is opened, the switches interrupt the circuit to all components. A cook cycle cannot take place until the door

is firmly closed thereby activating both interlock switches. The primary interlock system consists of the door sensing switch and primary interlock relay located on the control circuit board.

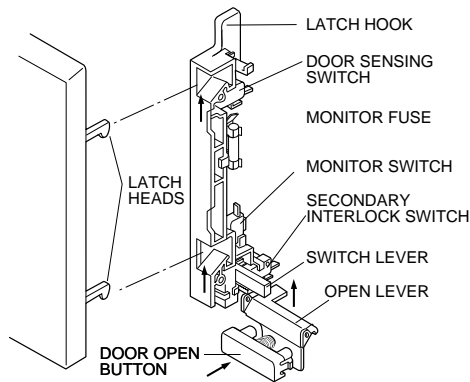

Figure D-1. Door sensing switch, monitor switch and secondary interlock switches

MONITOR SWITCH

The monitor switch is mounted on the middle position of latch hook. It is activated (the contacts opened) by the lower latch head while the door is closed. The switch is intended to render the oven inoperative by means of blowing the monitor fuse when the contacts of the primary interlock relay and secondary interlock switch fail to open when the door is opened.

Functions:

1. When the door is opened, the monitor switch contact close (to the ON condition) due to their being normally closed. At this time the door sensing and secondary interlock switches are in the OFF condition (contacts open) due to their being normally open contact switches.
2. As the door goes to a closed position, the monitor switch contacts are first opened and then the door sensing switch and the secondary interlock switch contacts close. (On opening the door, each of these switches operate inversely.)
3. If the door is opened, and the primary interlock relay and secondary interlock switch contacts fail to open, the monitor fuse blows simultaneously with closing of the monitor switch contacts.

CAUTION: BEFORE REPLACING A BLOWN MONITOR FUSE TEST THE DOOR SENSING SWITCH, PRIMARY INTERLOCK RELAY, SECONDARY INTERLOCK SWITCH AND MONITOR SWITCH FOR PROPER OPERATION. (REFER TO CHAPTER "TEST PROCEDURE").

NOTE: MONITOR FUSE AND MONITOR SWITCH ARE REPLACED AS AN ASSEMBLY.

THERMISTOR

The thermistor is a negative temperature coefficient type. The temperature in the oven cavity is detected through the resistance of the thermistor, and then the control unit causes the heater relay to operate, thus the current to the heating element is turned ON/OFF.

MAGNETRON TEMPERATURE FUSE.

The temperature fuse located on the waveguide is designed to prevent damage to the magnetron if an over heated

condition develops in the magnetron due to cooling fan failure, obstructed air guide, dirty or blocked air intake, etc. Under normal operation, the temperature fuse remains closed. However, when abnormally high temperatures are reached within the magnetron, the temperature fuse will open at 302°F(150°C) causing the oven to shut down.

CONV. THERMAL CUT-OUT

The thermal cut-out located on the left side of the thermal protection plate (left) is designed to prevent damage to the heater unit if an over heated condition develops in the heating unit due to convection fan failure, thermistor failure, obstructed air ducts, dirty or blocked air intake, etc. Under normal operation, the thermal cut-out remains closed. However, when abnormally high temperatures are reached within the heater unit, the thermal cut-out will open at 302°F(150°C) causing the oven to shut down. When the thermal cut-out has cooled, the thermal cut-out closes at 266°F(130°C).

HEATING ELEMENT

The heating element is located at the left side of the oven cavity. It is intended to heat air driven by the convection fan. The heated air is kept in the oven and force-circulated and reheated by the heating element.

CONVECTION COOKING SYSTEM

This oven is designed with a hot air heating system where food is not directly heated by the heating element, but is heated by forced circulation of the hot air produced by the heating element. The air heated by the heating element is circulated through the convection passage provided on the outer casing of the oven cavity by means of the convection fan which is driven by the convection motor. It then enters the inside of the oven through the vent holes provided on the left side of the oven. Next, the hot air heats the food on the turntable and leaves the oven cavity through the vent in the center of the oven cavity left side wall. Without leaving the oven, this hot air is reheated by the heating element, passes through the convection passage and enters the inside of the oven cavity again, in a continuing cycle. In this way, the hot air circulates inside the oven cavity to raise its temperature and, at the same time, comes into contact with the food being cooked. When the temperature inside the oven cavity reaches the selected temperature, the heating element is de-energized. When the temperature inside the oven cavity drops below the selected temperature, the heating element is energized again. In this way, the inside of the oven cavity is maintained at approximately the selected temperature. When the convection time reaches 0, the heating element is de-energized and the convection fan stops operating and the oven shuts off.

DAMPER OPEN-CLOSE MECHANISM

Usually, the damper is in the open position except during convection cooking. Damper position is set automatically by damper motor, damper switch, motor cam and damper shaft. These components are operated by a signal that judges if microwave cooking or convection cooking operation is selected by the control unit.

Microwave Cooking:

Damper is in the open position, because a portion of cooling

air is channelled through the cavity to remove steam and vapors given off from the heating foods. It is then exhausted at the top of the oven cavity into a condensation compartment.

Convection Cooking:

Damper is in the closed position, so that no hot air will be allowed to leak out the oven cavity.

Damper Operation

1. When power supply cord is plugged in:
 - 1-1. When power supply cord is plugged in, a signal is sensed in the control unit, and operates shut-off relay (RY4).
 - 1-2. Contacts of shut-off relay (RY4) close, the damper motor is energized, opening the damper door.
 - 1-3. When the damper is moved to the open position by the damper cam the damper switch is closed (ON position).
 - 1-4. The signal from damper switch is re-sensed in the control unit and shut-off relay (RY4) is turned off.
 - 1-5. The 120 volts A.C. to the damper motor is removed and the motor turns off.
2. When oven is microwave cooking:
Damper is in the open position.
3. When oven is convection cooking:
 - 3-1. Damper motor is energized by touching the convection, temperature and START pads.
 - 3-2. When damper is in the closed position (damper

switch is OFF), its signal is sensed by the control unit, and shut-off relay (RY4) is de-energized.

3-3. The damper is held in the closed position during the convection cooking operation.

3-4. At the end of the convection cooking, shut-off relay (RY4) is energized, and the damper is returned to the open position.

NOTE: If the damper door is not in the proper position, closed during convection or open during microwave, the control unit will stop oven operation after 1 minute.

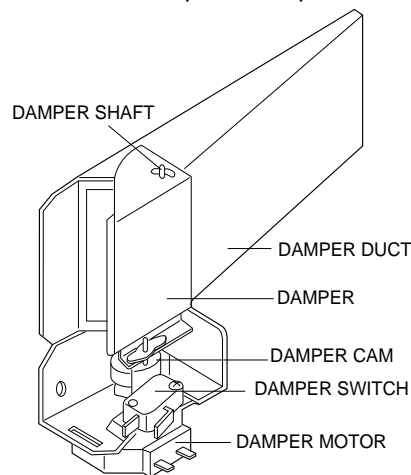

Figure D-2. Damper Mechanism

TROUBLESHOOTING GUIDE

Never touch any part in the circuit with your hand or an uninsulated tool while the power supply is connected.

When troubleshooting the microwave oven, it is helpful to follow the Sequence of Operation in performing the checks. Many of the possible causes of trouble will require that a specific test be performed. These tests are given a procedure letter which will be found in the "Test Procedure" section.

IMPORTANT: If the oven becomes inoperative because of a blown monitor fuse, check the monitor switch, relay (RY1) primary interlock relay (RY2), door sensing switch and secondary interlock switch before replacing the monitor fuse. If the monitor fuse is replaced, the monitor switch must also be replaced. Use part FFS-BA012WRK0 as an assembly.

IMPORTANT: Whenever troubleshooting is performed with the power supply cord disconnected. It may in, some cases, be necessary to connect the power supply cord after the outer case has been removed, in this event,

1. Disconnect the power supply cord, and then remove outer case.
2. Open the door and block it open.
3. Discharge high voltage capacitor.
4. Disconnect the leads to the primary of the power transformer.
5. Ensure that the leads remain isolated from other components and oven chassis by using insulation tape.
6. After that procedure, reconnect the power supply cord.

When the testing is completed

1. Disconnect the power supply cord, and then remove outer case.
2. Open the door and block it open.
3. Discharge high voltage capacitor.
4. Reconnect all leads removed from components during testing.
5. Reinstall the outer case (cabinet).
6. Reconnect the power supply cord after the outer case is installed.
7. Run the oven and check all functions.

TEST PROCEDURE	CONDITION	OFF CONDITION		COOKING CONDITION		(MICROWAVE)			(CONVECTION)			(SENSOR COOKING)	
		PROBLEM											
POSSIBLE CAUSE AND DEFECTIVE PARTS		Home fuse blows when power cord is plugged into wall receptacle. Monitor fuse blows when power cord is plugged into wall receptacle 88:88 does not appear in display when power cord is first plugged into wall receptacle. Display does not operate properly when STOP/CLEAR pad is touched. (The time of day should appear on the display with beep sound.) Oven lamp does not light with door opened. Oven lamp does not light in cook cycle. (It light when door is opened). Cooking cycle runs 1 minute then shuts down. Oven lamp light, but turntable motor does not operate. Turntable motor operates normally but cooling fan motor does not operate. Oven does not go into a cook cycle, when START pad is touched. Low or no power is produced during microwave cooking (The food is heated incompletely or not heated at all) Extremely uneven heating is produced in oven load (food). Function of variable cooking does not operate properly except HIGH power. Function of COMPU DEFROST does not operate properly. CONV indicator lights, but oven does not go into cook cycle when START pad is touched. CONV indicator lights, but heating element does not heat. Temperature in the oven cavity is lower or higher than preset. Cooling fan motor runs intermittently or all the time. Convection cycle runs 4 minutes and 15 seconds then shuts down. Oven in the sensor cooking condition but AH sensor does not end or AH sensor turns off about max. 30 min. after start.											
A	MAGNETRON												
B	POWER TRANSFORMER												
C	H.V. RECTIFIER ASSEMBLY												
D	HIGH VOLTAGE CAPACITOR												
E	SECONDARY INTERLOCK SWITCH												
F	PRIMARY INTERLOCK SYSTEM												
G	MONITOR SWITCH												
H	MONITOR FUSE												
I	MAGNETRON TEMPERATURE FUSE												
J	CONV. THERMAL CUT-OUT												
K	CONVECTION HEATER												
L	THERMISTOR												
M	DAMPER MOTOR												
N	DAMPER SWITCH												
P	TOUCH CONTROL PANEL												
Q	KEY UNIT												
R	RELAY RY-1												
R	RELAY RY-2												
R	RELAY RY-3												
R	RELAY RY-4												
R	RELAY RY-5												
R	RELAY RY-6												
S	COMP. DEFROST												
T	FOIL PATTERN ON PWB.												
U	AH SENSOR												
Replace	OVEN LAMP OR SOCKET												
Replace	FAN MOTOR												
Replace	TURNTABLE MOTOR												
Replace	CONVECTION MOTOR												
Check	LOOSE WIRING												
Check	SHORTED IN POWER CORD												
Check	NO POWER AT OUTLET												
Check	LOW VOLTAGE												

TEST PROCEDURES

PROCEDURE LETTER	COMPONENT TEST
A	<p><u>MAGNETRON ASSEMBLY TEST</u></p> <ol style="list-style-type: none"> 1. Disconnect the power supply cord, and then remove outer case. 2. Open the door and block it open. 3. Discharge high voltage capacitor. 4. To test for an open filament, isolate the magnetron from the high voltage circuit. A continuity check across the magnetron filament leads should indicate less than 1 ohm. 5. To test for a shorted magnetron, connect the ohmmeter leads between the magnetron filament leads and chassis ground. This test should indicate an infinite resistance. If there is little or no resistance the magnetron is grounded and must be replaced. 6. Reconnect all leads removed from components during testing. 7. Reinstall the outer case (cabinet). 8. Reconnect the power supply cord after the outer case is installed. 9. Run the oven and check all functions. <p><u>MICROWAVE OUTPUT POWER</u></p> <p>The following test procedure should be carried out with the microwave oven in a fully assembled condition (outer case fitted).</p> <p>HIGH VOLTAGES ARE PRESENT DURING THE COOK CYCLE, SO EXTREME CAUTION SHOULD BE OBSERVED.</p> <p>Power output of the magnetron can be measured by performing a water temperature rise test. This test should only be used if above tests do not indicate a faulty magnetron and there is no defect in the following components or wiring: silicon rectifier, high voltage capacitor and power transformer. This test will require a 16 ounce (453cc) measuring cup and an accurate mercury thermometer or thermocouple type temperature tester. For accurate results, the following procedure must be followed carefully:</p> <ol style="list-style-type: none"> 1. Fill the measuring cup with 16 oz. (453cc) of tap water and measure the temperature of the water with a thermometer or thermocouple temperature tester. Stir the thermometer or thermocouple through the water until the temperature stabilizes. Record the temperature of the water. 2. Place the cup of water in the oven. Operate oven at POWER 10(HIGH) selecting more than 60 seconds cook time. Allow the water to heat for 60 seconds, measuring with a stop watch, second hand of a watch or the digital read-out countdown. 3. Remove the cup from the oven and again measure the temperature, making sure to stir the thermometer or thermocouple through the water until the maximum temperature is recorded. 4. Subtract the cold water temperature from the hot water temperature. The normal result should be 22 to 43°F(12.2 to 23.8°C) rise in temperature. If the water temperatures are accurately measured and tested for the required time period the test results will indicate if the magnetron tube has low power output (low rise in water temperature) which would extend cooking time or high power output (high rise in water temperature) which would reduce cooking time. Because cooking time can be adjusted to compensate for power output, the magnetron tube assembly should be replaced only if the water temperature rise test indicates a power output well beyond the normal limits. The test is only accurate if the power supply line voltage is 120 volts and the oven cavity is clean.
B	<p><u>POWER TRANSFORMER TEST</u></p> <ol style="list-style-type: none"> 1. Disconnect the power supply cord, and then remove outer case. 2. Open the door and block it open. 3. Discharge high voltage capacitor. 4. Disconnect the primary input terminals and measure the resistance of the transformer with an ohmmeter. Check for continuity of the coils with an ohmmeter. On the R x 1 scale, the resistance of the primary coil should be less than 1 ohm and the resistance of the high voltage coil should be approximately 81.7 ohms; the resistance of the filament coil should be less than 1 ohm. 5. Reconnect all leads removed from components during testing. 6. Reinstall the outer case (cabinet). 7. Reconnect the power supply cord after the outer case is installed. 8. Run the oven and check all functions.

TEST PROCEDURES

**PROCEDURE
LETTER**
COMPONENT TEST

(HIGH VOLTAGES ARE PRESENT AT THE HIGH VOLTAGE TERMINAL, SO DO NOT ATTEMPT TO MEASURE THE FILAMENT AND HIGH VOLTAGE.)

C HIGH VOLTAGE RECTIFIER TEST

1. Disconnect the power supply cord, and then remove outer case.
2. Open the door and block it open.
3. Discharge high voltage capacitor.
4. Isolate the rectifier from the circuit. Using the highest ohm scale of the meter, read the resistance across the terminals and observe, reverse the leads to the rectifier terminals and observe meter reading. If a short is indicated in both directions, or if an infinite resistance is read in both directions, the rectifier is probably defective and should be replaced.
5. Reconnect all leads removed from components during testing.
6. Reinstall the outer case (cabinet).
7. Reconnect the power supply cord after the outer case is installed.
8. Run the oven and check all functions.

NOTE: Be sure to use an ohmmeter that will supply a forward bias voltage of more than 6.3 volts.

D HIGH VOLTAGE CAPACITOR TEST

1. Disconnect the power supply cord, and then remove outer case.
 2. Open the door and block it open.
 3. Discharge high voltage capacitor.
 4. If the capacitor is open, no high voltage will be available to the magnetron. Disconnect input leads and check for short or open between the terminals using an ohmmeter. Checking with a high ohm scale, if the high voltage capacitor is normal, the meter will indicate continuity for a short time and should indicate an open circuit once the capacitor is charged. If the above is not the case, check the capacitor with an ohmmeter to see if it is shorted between either of the terminals and case. If it is shorted, replace the capacitor.
 5. Reconnect all leads removed from components during testing.
 6. Reinstall the outer case (cabinet).
 7. Reconnect the power supply cord after the outer case is installed.
 8. Run the oven and check all functions.
-

E SECONDARY INTERLOCK SWITCH TEST

1. Disconnect the power supply cord, and then remove outer case.
 2. Open the door and block it open.
 3. Discharge high voltage capacitor.
 4. Isolate the switch and connect the ohmmeter to the common (COM.) and normally open (NO) terminal of the switch. The meter should indicate an open circuit with the door open and a closed circuit with the door closed. If improper operation is indicated, replace the secondary interlock switch.
 5. Reconnect all leads removed from components during testing.
 6. Reinstall the outer case (cabinet).
 7. Reconnect the power supply cord after the outer case is installed.
 8. Run the oven and check all functions.
-

F PRIMARY INTERLOCK SYSTEM TEST
DOOR SENSING SWITCH

1. Disconnect the power supply cord, and then remove outer case.
2. Open the door and block it open.
3. Discharge high voltage capacitor.
4. Isolate the switch and connect the ohmmeter to the common (COM.) and normally open (NO) terminal of the switch. The meter should indicate an open circuit with the door open and a closed circuit with the door closed. If improper operation is indicated, replace the door sensing switch.

TEST PROCEDURES

PROCEDURE LETTER	COMPONENT TEST
------------------	----------------

5. Reconnect all leads removed from components during testing.
6. Reinstall the outer case (cabinet).
7. Reconnect the power supply cord after the outer case is installed.
8. Run the oven and check all functions.

NOTE: If the door sensing switch contacts fail in the open position and the door is closed, the turntable motor and oven light will be activated by RY1.

PRIMARY INTERLOCK RELAY (RY2)

1. Disconnect the power supply cord, and then remove outer case.
2. Open the door and block it open.
3. Discharge high voltage capacitor.
4. Disconnect two (2) wire leads from the male tab terminals of the Primary Interlock Relay (RY2). Check the state of the relay contacts using a ohmmeter. The relay contacts should be open. If the relay contacts are closed, replace the circuit board entirely or the relay itself.
5. Reconnect all leads removed from components during testing.
6. Reinstall the outer case (cabinet).
7. Reconnect the power supply cord after the outer case is installed.
8. Run the oven and check all functions.

G MONITOR SWITCH

1. Disconnect the power supply cord, and then remove outer case.
2. Open the door and block it open.
3. Discharge high voltage capacitor.
4. Before performing this test, make sure that the secondary interlock switch and the primary interlock relay are operating properly, according to the above Switch Test Procedure. Disconnect the wire lead from the monitor switch (COM) terminal. Check the monitor switch operation by using the ohmmeter as follows. When the door is open, the meter should indicate a closed circuit. When the monitor switch actuator is pushed by a screw driver through the lower latch hole on the front plate of the oven cavity with the door opened (in this condition the plunger of the monitor switch is pushed in), the meter should indicate an open circuit. If improper operation is indicated, the switch may be defective. After testing the monitor switch, reconnect the wire lead to the monitor switch (COM) terminal and check the continuity of the monitor circuit.
5. Reconnect all leads removed from components during testing.
6. Reinstall the outer case (cabinet).
7. Reconnect the power supply cord after the outer case is installed.
8. Run the oven and check all functions.

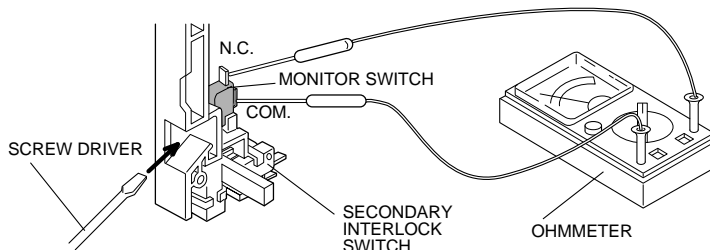

H BLOWN MONITOR FUSE

1. Disconnect the power supply cord, and then remove outer case.
2. Open the door and block it open.
3. Discharge high voltage capacitor.
4. If the monitor fuse is blown when the door is opened, check the primary interlock relay, secondary interlock switch and monitor switch according to the "TEST PROCEDURE" for those switches before replacing the blown monitor fuse.

CAUTION: BEFORE REPLACING A BLOWN MONITOR FUSE, TEST THE PRIMARY INTERLOCK RELAY, SECONDARY INTERLOCK SWITCH, DOOR SENSING SWITCH AND MONITOR SWITCH FOR PROPER OPERATION.

If the monitor fuse is blown by improper switch operation, the monitor fuse and monitor switch must be replaced with "monitor fuse and monitor switch assembly" part number FFS-BA012WRK0, even if the monitor switch operates normally. The monitor fuse and monitor switch assembly is comprised of a 20 ampere fuse and switch.

TEST PROCEDURES

**PROCEDURE
LETTER**
COMPONENT TEST

5. Reconnect all leads removed from components during testing.
 6. Reinstall the outer case (cabinet).
 7. Reconnect the power supply cord after the outer case is installed.
 8. Run the oven and check all functions.
-

I MAGNETRON TEMPERATURE FUSE TEST

1. Disconnect the power supply cord, and then remove outer case.
2. Open the door and block it open.
3. Discharge high voltage capacitor.
4. A continuity check across the temperature fuse terminals should indicate a closed circuit unless the temperature of the magnetron reaches approximately 302°F(150°C). An open temperature fuse indicates overheating of the magnetron. Check for restricted air flow to the magnetron, especially the cooling duct and cooling fan.
5. Reconnect all leads removed from components during testing.
6. Reinstall the outer case (cabinet).
7. Reconnect the power supply cord after the outer case is installed.
8. Run the oven and check all functions.

CAUTION: IF THE TEMPERATURE FUSE INDICATES AN OPEN CIRCUIT AT ROOM TEMPERATURE, REPLACE TEMPERATURE FUSE.

J CONV. THERMAL CUT-OUT TEST

1. Disconnect the power supply cord, and then remove outer case.
2. Open the door and block it open.
3. Discharge high voltage capacitor.
4. A continuity check across the thermal cut-out terminals should indicate a closed circuit unless the temperature of the thermal cut-out reaches approximately 302°F(150°C). The thermal cut-out resets automatically at approximately 266°F(130°C). If thermal cut-out has opened under normal condition, replace the same item as in the parts list.
An open thermal cut-out indicates overheating of the heater unit. Check for restricted air flow to the heater unit through the vent holes of the oven cavity, especially the heater duct and convection fan.
5. Reconnect all leads removed from components during testing.
6. Reinstall the outer case (cabinet).
7. Reconnect the power supply cord after the outer case is installed.
8. Run the oven and check all functions.

CAUTION: IF THE THERMAL CUT-OUT INDICATES AN OPEN CIRCUIT AT ROOM TEMPERATURE, REPLACE THERMAL CUT-OUT.

K HEATING ELEMENT TEST

1. Disconnect the power supply cord, and then remove outer case.
2. Open the door and block it open.
3. Discharge high voltage capacitor.
4. Make sure the heating element is fully cooled and test as follows;
 - a. Disconnect wire leads from the heating element and measure the resistance with an ohmmeter. On the R x 1 scale, the resistance between the heating element terminals should be approximately 10.2Ω.
 - b. Disconnect wire leads from the heating element and measure the insulation resistance with 500V - 100MΩ insulation resistance meter. The insulation resistance between heating element terminal and cavity should be more than 0.5MΩ.
5. If the meter does not indicate above resistance, replace the thermistor
6. Reconnect all leads removed from components during testing.
7. Reinstall the outer case (cabinet).
8. Reconnect the power supply cord after the outer case is installed.
9. Run the oven and check all functions.

TEST PROCEDURES

PROCEDURE LETTER	COMPONENT TEST
------------------	----------------

L THERMISTOR TEST

1. Disconnect the power supply cord, and then remove outer case.
2. Open the door and block it open.
3. Discharge high voltage capacitor.
4. Disconnect connector-E from the control unit. Measure the resistance of the thermistor with an ohmmeter. Connect the ohmmeter leads to Pin No's E-3 and E-4.

Room Temperature	Resistance
68°F(20°C) - 86°F(30°C)	Approx. 350kΩ - 155KΩ

5. If the meter does not indicate above resistance, replace the thermistor.
6. Reconnect all leads removed from components during testing.
7. Reinstall the outer case (cabinet).
8. Reconnect the power supply cord after the outer case is installed.
9. Run the oven and check all functions.

M DAMPER MOTOR TEST

When the power cord is plugged into the wall receptacle and 120 volts A.C. is supplied to the damper motor, the motor operates until the damper is opened and the damper switch closes. Then the damper motor stops operation.

If the damper motor does not operate, check for A.C. voltage with a voltmeter at the motor.

1. Disconnect the power supply cord, and then remove outer case.
2. Open the door and block it open.
3. Discharge high voltage capacitor.
4. Disconnect the leads to the primary of the power transformer.
5. Ensure that the leads remain isolated from other components and oven chassis by using insulation tape.
6. Disconnect the wire leads of motor and connect the meter leads to the wire leads of main wire harness.
7. Re-connect the power cord into the wall receptacle.
8. If 120 volts A.C. is indicated at the wire leads, replace the motor and if 120 volts A.C. is not indicated, check the wire harness and control unit.
9. Disconnect the power supply cord, and then remove outer case.
10. Open the door and block it open.
11. Discharge high voltage capacitor.
12. Reconnect all leads removed from components during testing.
13. Re-install the outer case (cabinet).
14. Reconnect the power supply cord after the outer case is installed.
15. Run the oven and check all functions.

N DAMPER SWITCH TEST

1. Disconnect the power supply cord, and then remove outer case.
2. Open the door and block it open.
3. Discharge high voltage capacitor.
4. Disconnect the leads to the primary of the power transformer.
5. Ensure that the leads remain isolated from other components and oven chassis by using insulation tape.
6. Disconnect the wire leads from the switch terminals and connect ohmmeter leads to the common (COM.) and normally open (N.O.) terminals of the switch.
- 6-1. When switch actuator is pushed by the damper motor cam, the meter should be indicated a closed circuit.
- 6-2. When power cord is plugged into the wall receptacle, the damper motor operates and damper cam will start to rotate. When the switch actuator is released, the meter should be indicated an open circuit.
7. If improper operation is indicated, replace the damper switch.
8. Disconnect the power supply cord, and then remove outer case.

TEST PROCEDURES

PROCEDURE LETTER	COMPONENT TEST
	9. Open the door and block it open. 10. Discharge high voltage capacitor. 11. Reconnect all leads removed from components during testing. 12. Re-install the outer case (cabinet). 13. Reconnect the power supply cord after the outer case is installed. 14. Run the oven and check all functions.

O CHECKING TEMPERATURE IN THE CONVECTION MODE

The following test procedure should be carried out with the microwave oven in a fully assembled condition (outer case fitted).

It is difficult to measure the exact temperature in the convection oven. An accurate thermocouple type temperature tester must be used. A low priced bi-metal type thermometer is not reliable or accurate. The temperature should be checked with outer case cabinet installed, approx. 5 minutes after preheat temperature is reached (audible signal sounds four times). The temperature experienced may be approx. 30°F more or less than indicated on the display, however, in most cases the food cooking results will be satisfactory.

Difference in power supply voltage will also affect the oven temperature. The Household power supply voltage may sometimes become lower than the rated voltage (120 V) and cause under-cooking. If the power supply voltage is 10% lower than the rated voltage, longer cooking time is required by 10% to 20%.

P TOUCH CONTROL PANEL ASSEMBLY TEST

The touch control panel consists of circuits including semiconductors such as LSI, ICs, etc. Therefore, unlike conventional microwave ovens, proper maintenance cannot be performed with only a voltmeter and ohmmeter.

In this service manual, the touch control panel assembly is divided into two units, Control Unit and Key Unit, and troubleshooting by unit replacement is described according to the symptoms indicated.

Before testing,

- 1) Disconnect the power supply cord, and then remove outer case.
- 2) Open the door and block it open.
- 3) Discharge high voltage capacitor.
- 4) Disconnect the leads to the primary of the power transformer.
- 5) Ensure that these leads remain isolated from other components and oven chassis by using insulation tape.

1. Key Unit.

NOTE ;

- 1) Check Key unit ribbon connection before replacement.
- 2) Reconnect all leads removed from components during testing.
- 3) Re-install the outer case (cabinet).
- 4) Reconnect the power supply cord after the outer case is installed.
- 5) Run the oven and check all functions.

The following symptoms indicate a defective key unit.

- a) When touching the pads, a certain pad produces no signal at all.
- b) When touching a number pad, two figures or more are displayed.
- c) When touching the pads, sometimes a pad produces no signal.

If the Key unit is defective.

- 1) Disconnect the power supply cord, and then remove outer case.
- 2) Open the door and block it open.
- 3) Discharge high voltage capacitor.
- 4) Replace the Key unit.
- 5) Reconnect all leads removed from components during testing.
- 6) Re-install the outer case (cabinet).
- 7) Reconnect the power supply cord after the outer case is installed.
- 8) Run the oven and check all functions.

TEST PROCEDURES

PROCEDURE
LETTER

COMPONENT TEST

2. Control Unit
The following symptoms indicate a defective control unit. Before replacing the control unit, perform the Key unit test (Procedure Q) to determine if control unit is faulty. Reconnect the power supply cord. And check for followings.
- 2-1 In connection with pads.
- When touching the pads, a certain group of pads do not produce a signal.
 - When touching the pads, no pads produce a signal.
- 2-2 In connection with indicators
- At a certain digit, all or some segments do not light up.
 - At a certain digit, brightness is low.
 - Only one indicator does not light.
 - The corresponding segments of all digits do not light up; or they continue to light up.
 - Wrong figure appears.
 - A certain group of indicators do not light up.
 - The figure of all digits flicker.
- 2-3 Other possible problems caused by defective control unit.
- Buzzer does not sound or continues to sound.
 - Clock does not operate properly.
 - Cooking is not possible.
- When testing is completed,
- Disconnect the power supply cord, and then remove outer case.
 - Open the door and block it open.
 - Discharge high voltage capacitor.
 - Reconnect all leads removed from components during testing.
 - Re-install the outer case (cabinet).
 - Reconnect the power supply cord after the outer case is installed.
 - Run the oven and check all functions.

Q

KEY UNIT TEST

- Disconnect the power supply cord, and then remove outer case.
- Open the door and block it open.
- Discharge high voltage capacitor.
- If the display fails to clear when the STOP/CLEAR pad is depressed, first verify the flat ribbon cable is making good contact, verify that the door sensing switch (stop switch) operates properly; that is the contacts are closed when the door is closed and open when the door is open. If the door sensing switch (stop switch) is good, disconnect the flat ribbon cable that connects the key unit to the control unit and make sure the door sensing switch is closed (either close the door or short the door sensing switch connector). Use the Key unit matrix indicated on the control panel schematic and place a jumper wire between the pins that correspond to the STOP/CLEAR pad making momentary contact. If the control unit responds by clearing with a beep the key unit is faulty and must be replaced. If the control unit does not respond, it is faulty and must be replaced. If a specific pad does not respond, the above method may be used (after clearing the control unit) to determine if the control unit or key pad is at fault.
- Reconnect all leads removed from components during testing.
- Re-install the outer case (cabinet).
- Reconnect the power supply cord after the outer case is installed.
- Run the oven and check all functions.

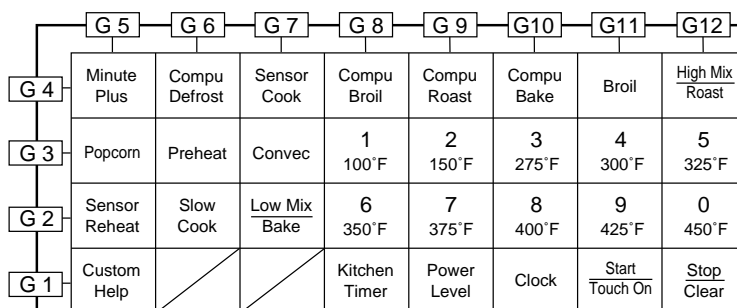

TEST PROCEDURES

PROCEDURE LETTER	COMPONENT TEST
------------------	----------------

R RELAY TEST

1. Disconnect the power supply cord, and then remove outer case.
2. Open the door and block it open.
3. Discharge high voltage capacitor.
4. Disconnect the leads to the primary of the power transformer.
5. Ensure that these leads remain isolated from other components and oven chassis by using insulation tape.
6. After that procedure, re-connect the power supply cord.
7. Remove the outer case and check voltage between Pin Nos. 7 and 9 of the 9 pin connector (A) on the control unit with an A.C. voltmeter. The meter should indicate 120 volts, if not check oven circuit.

Shut-off, Cook and Heater Relays Test

These relays are operated by D.C. voltage

Check voltage at the relay coil with a D.C. voltmeter during the microwave cooking operation or convection cooking condition.

DC. voltage indicated Defective relay.

DC. voltage not indicated Check diode which is connected to the relay coil. If diode is good, control unit is defective.

RELAY SYMBOL	OPERATIONAL VOLTAGE	CONNECTED COMPONENTS
RY1	Approx. 19.0V D.C.	Oven lamp / Turntable motor
RY2 (COOK)	Approx. 18.0V D.C.	Power transformer
RY3 (HEATER)	Approx. 18.0V D.C.	Heating element
RY4	Approx. 19.0V D.C.	Damper motor
RY5	Approx. 19.0V D.C.	Convection motor
RY6	Approx. 19.0V D.C.	Cooling fan motor

8. Disconnect the power supply cord, and then remove outer case.
9. Open the door and block it open.
10. Discharge high voltage capacitor.
11. Reconnect all leads removed from components during testing.
12. Re-install the outer case (cabinet).
13. Reconnect the power supply cord after the outer case is installed.
14. Run the oven and check all functions.

S COMPU DEFROST TEST

WARNING : The oven should be fully assembled before following procedure.

- (1) Place one cup of water in the center of the turntable tray in the oven cavity.
- (2) Close the door, touch the Compu Defrost pad twice and touch the number pad 5. And then touch the start pad.
- (3) The oven is in Compu Defrost cooking condition.
- (4) The oven will operate as follows

WEIGHT	1ST STAGE		2ND STAGE		3RD STAGE		4TH STAGE	
	LEVEL	TIME	LEVEL	TIME	LEVEL	TIME	LEVEL	TIME
0.5lbs	70%	47sec.	0%	52sec.	50%	32sec.	30%	40sec.

- (5) If improper operation is indicated, the control unit is probably defective and should be checked.

T PROCEDURES TO BE TAKEN WHEN THE FOIL PATTERN ON THE PRINTED WIRING BOARD (PWB) IS OPEN.

To protect the electronic circuits, this model is provided with a fine foil pattern added to the primary on the PWB, this foil pattern acts as a fuse.

1. Foil pattern check and repairs.
 - 1) Disconnect the power supply cord, and then remove outer case.
 - 2) Open the door and block it open.

TEST PROCEDURES

PROCEDURE
LETTER

COMPONENT TEST

- 3) Discharge high voltage capacitor.
- 4) Follow the troubleshooting guide given below for repair.

STEPS	OCCURRENCE	CAUSE OR CORRECTION
1	Only pattern at "a" is broken.	*Insert jumper wire J1 and solder.
2	Pattern at "a" and "b" are broken.	*Insert the coil RCILF2003YAZZ between "c" and "d".

- 5) Make a visual inspection of the varistor. Check for burned damage and examine the transformer with a tester for the presence of layer short-circuit (check the primary coil resistance which is approximately $175\Omega \pm 10\%$). If any abnormal condition is detected, replace the defective parts.

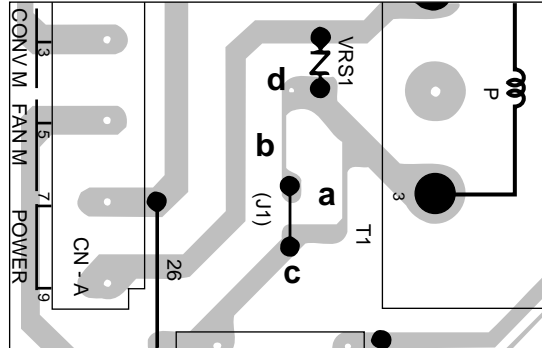

- 6) Reconnect all leads removed from components during testing.
 - 7) Re-install the outer case (cabinet).
 - 8) Reconnect the power supply cord after the outer case is installed.
 - 9) Run the oven and check all functions.
2. Follow the troubleshooting guide given below, if indicator does not light up after above check and repairs are finished.
 - 1) Disconnect the power supply cord, and then remove outer case.
 - 2) Open the door and block it open.
 - 3) Discharge high voltage capacitor.
 - 4) Disconnect the leads to the primary of the power transformer.
 - 5) Ensure that these leads remain isolated from other components and oven chassis by using insulation tape.
 - 6) After that procedure, re-connect the power supply cord.
 - 7) Follow the troubleshooting guide given below for repair.

STEPS	OCCURRENCE	CAUSE OR CORRECTION
1	The rated AC voltage is not present to power terminal of CPU connector (CN-A).	Check supply voltage and oven power cord.
2	The rated AC voltage is present at primary side of low voltage transformer.	Low voltage transformer or secondary circuit defective. Check and repair.

- 8) Disconnect the power supply cord, and then remove outer case.
- 9) Open the door and block it open.
- 10) Discharge high voltage capacitor.
- 11) Reconnect all leads removed from components during testing.
- 12) Re-install the outer case (cabinet).
- 13) Reconnect the power supply cord after the outer case is installed.
- 14) Run the oven and check all functions.

U

AH SENSOR TEST**Checking the initial sensor cooking condition**

WARNING : The oven should be fully assembled before following procedure.

- (1) The oven should be plugged in at least two minutes before sensor cooking.
- (2) Room temperature should not exceed 95°F (35°C).
- (3) The unit should not be installed in any area where heat and steam are generated. The unit should not be installed, for example, next to a conventional surface unit. Refer to the "INSTALLATION INSTRUCTIONS" of the operation manual.
- (4) Exhaust vents are provided on the back of the unit for proper cooling and air flow in the cavity. To

TEST PROCEDURES

PROCEDURE LETTER	COMPONENT TEST
	<p>permit adequate ventilation, be sure to install so as not to block these vents. There should be some space for air circulation.</p> <ol style="list-style-type: none"> (5) Be sure the exterior of the cooking container and the interior of the oven are dry. Wipe off any moisture with a dry cloth or paper towel. (6) The Sensor works with food at normal storage temperature. For example, chicken pieces would be at refrigerator temperature and canned soup at room temperature. (7) Avoid using aerosol sprays or cleaning solvents near the oven while using Sensor settings. The sensor will detect the vapor given off by the spray and turn off before food is properly cooked. (8) If the sensor has not detected the vapor of the food, ERROR will appear and the oven will shut off. <p>Water load cooking test</p> <p>WARNING : The oven should be fully assembled before following procedure. Make sure the oven has been plugged in at least two minutes before checking sensor cook operation. The cabinet should be installed and screws tightened.</p> <ol style="list-style-type: none"> (1) Fill approximately 200 milliliters (7.2 oz) of tap water in a 1000 milliliter measuring cup. (2) Place the container on the center of tray in the oven cavity. (3) Close the door. (4) Touch SENSOR COOK pad and then touch the number pad 1. And touch Start pad. Now, the oven is in the sensor cooking condition and "BAKED POTATO" will appear in the display. (5) The oven will operate for the first 16 seconds, without generating microwave energy. When the AH sensor is defective (open or short), Error will appear in the display after 16 seconds cleaning time. If ERROR appears, check sensor wire connecting and/or AH sensor. <p>NOTE: ERROR will appear if the door is opened or STOP/CLEAR pad is touched during first stage of sensor cooking.</p> <ol style="list-style-type: none"> (6) After approximately 16 seconds, microwave energy is produced, and the display should start to count down the remaining cooking time and oven should turn off after water is boiling (bubbling). If the oven does not turn off, replace the AH sensor or check the control unit, refer to explanation below. <p style="text-align: center;"><u>TESTING METHOD FOR AH SENSOR AND/OR CONTROL UNIT</u></p> <p>To determine if the sensor is defective, the simplest method is to replace it with a new replacement sensor.</p> <ol style="list-style-type: none"> (1) Disconnect the power supply cord, and then remove outer case. (2) Open the door and block it open. (3) Discharge high voltage capacitor. (4) Remove the AH sensor. (5) Install the new AH sensor. (6) Reconnect all leads removed from components during testing. (7) Re-install the outer case (cabinet). (8) Reconnect the power supply cord after the outer case is installed. (9) Check the sensor cook operation as follows: <ol style="list-style-type: none"> 9-1. Fill approximately 200 milliliters (7.2 oz) of tap water in a 1000 milliliter measuring cup. 9-2. Place the container on the center of tray in the oven cavity. 9-3. Close the door. 9-4. Touch SENSOR COOK pad and then touch the number pad 1. And touch Start pad. 9-5. The control panel is in automatic Sensor operation. 9-6. The display will start to count down the remaining cooking time, and the oven will turn off automatically after the water is boiling (bubbling). <p>If new sensor does not operate properly, the problem is with the control unit, and refer to explanation below.</p> <p style="text-align: center;"><u>CHECKING CONTROL UNIT</u></p> <ol style="list-style-type: none"> (1) Disconnect the power supply cord, and then remove outer case. (2) Open the door and block it open. (3) Discharge high voltage capacitor. (4) Disconnect the sensor connector that is mounted to control panel. (5) Then connect the dummy resistor circuit (see fig.) to the sensor connector of control panel. (6) Disconnect the leads to the primary of the power transformer. (7) Ensure that these leads remain isolated from other components and oven chassis by using insulation tape.

TEST PROCEDURES

PROCEDURE
LETTER

COMPONENT TEST

- (8) After that procedure, re-connect the power supply cord.
- (9) Check the sensor cook operation proceed as follows:
- 9-1. Touch SENSOR COOK pad and then touch the number pad 1. And touch Start pad.
 - 9-2. The control panel is in the sensor cooking operation.
 - 9-3. After approximately 20 seconds, push plunger of select switch for more than 3 seconds. This condition is same as judgement by AH sensor.
 - 9-4. After approximately 3 seconds, the display shows " X X . X X " which is the remaining cooking time, and the display count down.
- If the above is not the case, the control unit is probably defective.
If the above is proper, the AH sensor is probably defective.
- (10) Disconnect the power supply cord, and then remove outer case.
- (11) Open the door and block it open.
- (12) Discharge high voltage capacitor.
- (13) Disconnect the dummy resistor circuit from the sensor connector of control panel.
- (14) Carry out necessary repair.
- (15) Reconnect all leads removed from components during testing and repairing.
- (16) Re-install the outer case (cabinet).
- (17) Reconnect the power supply cord after the outer case is installed. Run the oven and check all functions.
- (18) Carry out "Water load cooking test" again and ensure that the oven works properly.

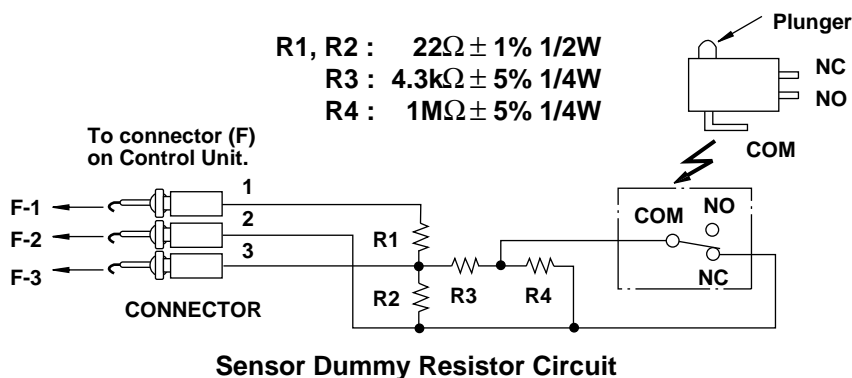

TOUCH CONTROL PANEL ASSEMBLY

OUTLINE OF TOUCH CONTROL PANEL

The touch control section consists of the following units as shown in the touch control panel circuit.

- (1) Key Unit
- (2) Control Unit

The principal functions of these units and the signals communicated among them are explained below.

Key Unit

The key unit is composed of a matrix, signals P10 - P17 generated in the LSI are sent to the key unit. When a key pad is touched, a signal is completed through the key unit and passed back to the LSI through R24 - R27 to perform the function that was requested.

Control Unit

Control unit consists of LSI, power source circuit, synchronizing signal circuit, ACL circuit, buzzer circuit, temperature measurement circuit, absolute humidity sensor circuit and indicator circuit.

1) LSI

This LSI controls the temperature measurement signal, AH sensor signal, key strobe signal, relay driving signal for oven function and indicator signal.

2) Power Source Circuit

This circuit generates the voltages necessary for the control unit from the AC line voltage.

3) Synchronizing Signal Circuit

The power source synchronizing signal is available in order to compose a basic standard time in the clock circuit. It incorporates a very small error because it works on commercial frequency.

4) ACL Circuit

A circuit to generate a signals which resetting the LSI to the initial state when power is applied.

5) Buzzer Circuit

The buzzer is responds to signals from the LSI to emit noticing sounds (key touch sound and completion sound).

6) Temperature Measurement Circuit : (OVEN THERMISTOR)

The temperature in the oven cavity is sensed by the thermistor. The variation of resistance according to sensed temperature is detected by the temperature measurement circuit and the result applied to LSI. The LSI uses this information to control the relay and display units.

7) Absolute Humidity Sensor Circuit

This circuit detects the humidity of a food which is being cooked, to control its automatic cooking.

8) Door Sensing Switch

A switch to inform the LSI if the door is open or closed.

9) Relay Circuit

To drive the magnetron, heating element, fan motor, convection motor, damper motor, turntable motor and light the oven lamp.

10) Indicator Circuit

Indicator element is a Fluorescent Display. Basically, a Fluorescent Display is triode having a cathode, a grid and an anode. Usually, the cathode of a Fluorescent Display is directly heated and the filament serves as cathode.

The Fluorescent Display has 8-digits, 16-segments are used for displaying figures.

DESCRIPTION OF LSI

LSI(IZA797DR):

The I/O signals of the LSI(IZA797DR) are detailed in the following table.

Pin No.	Signal	I/O	Description
1	VCC	IN	Connected to GND.
2	VEE	IN	Anode (segment) of Fluorescent Display light-up voltage: -30V. Vp voltage of power source circuit input.
3	AVSS	IN	Power source voltage: -5V. VC voltage of power source circuit input.
4	VREF	IN	Reference voltage input terminal. A reference voltage applied to the A/D converter in the LSI. Connected to GND.(0V)

Pin No.	Signal	I/O	Description																																				
5	AN7	IN	Used for initial balancing of the bridge circuit (absolute humidity sensor). This input is an analog input terminal from the AH sensor circuit, and connected to the A/D converter built into the LSI.																																				
6	AN6	IN	AH sensor input. This input is an analog input terminal from the AH sensor circuit, and connected to the A/D converter built into the LSI.																																				
7-9	AN5-AN3	IN	Heating constant compensation terminal.																																				
10	AN2	IN	Input signal which communicates the door open/close information to LSI. Door closed; "H" level signal(0V). Door opened; "L" level signal(-5V).																																				
11	AN1	IN	Input signal which communicates the damper open/close information to LSI. Damper opened; "H" level signal(0V:GND). Damper closed; "L" level signal(-5V).																																				
12	AN0	IN	Temperature measurement input: OVEN THERMISTOR. By inputting DC voltage corresponding to the temperature detected by the thermistor, this input is converted into temperature by the A/D converter built into the LSI.																																				
13	P55	OUT	<p>Digit selection signal. The relationship between digit signal and digit are as follows;</p> <table border="1"> <thead> <tr> <th>Digit signal</th> <th>Digit</th> </tr> </thead> <tbody> <tr> <td>P03.....</td> <td>1st.</td> </tr> <tr> <td>P02.....</td> <td>2nd.</td> </tr> <tr> <td>P01.....</td> <td>3rd.</td> </tr> <tr> <td>P00.....</td> <td>4th.</td> </tr> <tr> <td>P37.....</td> <td>5th.</td> </tr> <tr> <td>P36.....</td> <td>6th.</td> </tr> <tr> <td>P35.....</td> <td>7th.</td> </tr> <tr> <td>P55.....</td> <td>8th.</td> </tr> </tbody> </table> <p>Normally, one pulse is output in every β period, and input to the grid of the Fluorescent Display.</p>	Digit signal	Digit	P03.....	1st.	P02.....	2nd.	P01.....	3rd.	P00.....	4th.	P37.....	5th.	P36.....	6th.	P35.....	7th.	P55.....	8th.																		
Digit signal	Digit																																						
P03.....	1st.																																						
P02.....	2nd.																																						
P01.....	3rd.																																						
P00.....	4th.																																						
P37.....	5th.																																						
P36.....	6th.																																						
P35.....	7th.																																						
P55.....	8th.																																						
14	P54	OUT	<p>Oven lamp and turntable motor driving signal. (Square Waveform : 60Hz) To turn on and off the shut-off relay(RY1). The square waveform voltage is delivered to the relay(RY1) driving circuit.</p>																																				
15	P53	OUT	<p>Convection motor driving signal. To turn on and off shut-off relay(RY5). "L" level during CONVECTION; "H" level otherwise.</p>																																				
16	P52	OUT	<p>Cooling fan motor driving signal. To turn on and off shut-off relay(RY6). "L" level during both microwave and convection cooking; "H" level otherwise.</p>																																				
17	P51	OUT	<p>Magnetron high-voltage circuit driving signal.</p> <p>To turn on and off the cook relay(RY2). In P-HI operation, the signals holds "L" level during microwave cooking and "H" level while not cooking. In other cooking modes (P-90, P-80, P-70, P-60, P-50, P-40, P-30, P-20, P-10, P-0) the signal turns to "H" level and "L" level in repetition according to the power level.</p> <table border="1"> <thead> <tr> <th>VARI MODE</th> <th>ON TIME</th> <th>OFF TIME</th> </tr> </thead> <tbody> <tr> <td>P-HI (100% power)</td> <td>32 sec.</td> <td>0 sec.</td> </tr> <tr> <td>P-90 (approx. 90% power)</td> <td>30 sec.</td> <td>2 sec.</td> </tr> <tr> <td>P-80 (approx. 80% power)</td> <td>26 sec.</td> <td>6 sec.</td> </tr> <tr> <td>P-70 (approx. 70% power)</td> <td>24 sec.</td> <td>8 sec.</td> </tr> <tr> <td>P-60 (approx. 60% power)</td> <td>22 sec.</td> <td>10 sec.</td> </tr> <tr> <td>P-50 (approx. 50% power)</td> <td>18 sec.</td> <td>14 sec.</td> </tr> <tr> <td>P-40 (approx. 40% power)</td> <td>16 sec.</td> <td>16 sec.</td> </tr> <tr> <td>P-30 (approx. 30% power)</td> <td>12 sec.</td> <td>20 sec.</td> </tr> <tr> <td>P-20 (approx. 20% power)</td> <td>8 sec.</td> <td>24 sec.</td> </tr> <tr> <td>P-10 (approx. 10% power)</td> <td>6 sec.</td> <td>26 sec.</td> </tr> <tr> <td>P-0 (0% power)</td> <td>0 sec.</td> <td>32 sec.</td> </tr> </tbody> </table>	VARI MODE	ON TIME	OFF TIME	P-HI (100% power)	32 sec.	0 sec.	P-90 (approx. 90% power)	30 sec.	2 sec.	P-80 (approx. 80% power)	26 sec.	6 sec.	P-70 (approx. 70% power)	24 sec.	8 sec.	P-60 (approx. 60% power)	22 sec.	10 sec.	P-50 (approx. 50% power)	18 sec.	14 sec.	P-40 (approx. 40% power)	16 sec.	16 sec.	P-30 (approx. 30% power)	12 sec.	20 sec.	P-20 (approx. 20% power)	8 sec.	24 sec.	P-10 (approx. 10% power)	6 sec.	26 sec.	P-0 (0% power)	0 sec.	32 sec.
VARI MODE	ON TIME	OFF TIME																																					
P-HI (100% power)	32 sec.	0 sec.																																					
P-90 (approx. 90% power)	30 sec.	2 sec.																																					
P-80 (approx. 80% power)	26 sec.	6 sec.																																					
P-70 (approx. 70% power)	24 sec.	8 sec.																																					
P-60 (approx. 60% power)	22 sec.	10 sec.																																					
P-50 (approx. 50% power)	18 sec.	14 sec.																																					
P-40 (approx. 40% power)	16 sec.	16 sec.																																					
P-30 (approx. 30% power)	12 sec.	20 sec.																																					
P-20 (approx. 20% power)	8 sec.	24 sec.																																					
P-10 (approx. 10% power)	6 sec.	26 sec.																																					
P-0 (0% power)	0 sec.	32 sec.																																					

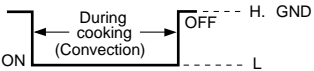
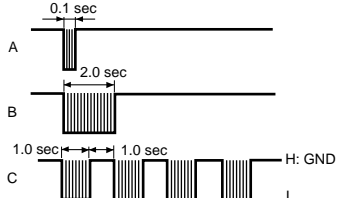
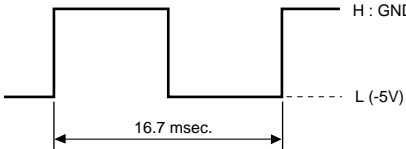
Pin No.	Signal	I/O	Description
18	P50	OUT	<p>Damper motor relay driving signal.</p> <p>To turn on and off shut-off relay(RY4).</p> 
19	P47	OUT	<p>Heating element driving signal.</p> <p>To turn on and off shut-off relay(RY3). "L" level during convection cooking; "H" level otherwise. During convection cooking, the signal becomes "H" level when the temperature of the oven cavity exceeds the predetermined temperature.</p> 
20-21	P46-P45	OUT	Terminal not used.
22	P44	OUT	<p>Timing signal output terminal for temperature measurement(OVEN THERMISTOR).</p> <p>"H" level (GND) : Thermistor OPEN timing. "L" level (-5V) : Temperature measuring timing.(Convection cooking)</p>
23	P43	OUT	<p>Signal to sound buzzer.</p> <p>A: key touch sound. B: Completion sound. C: When the temperature of the oven cavity reaches the preset temperature in the preheating mode, or when the preheating hold time (30 minutes) is elapsed.</p> 
24	P42	OUT	<p>Timing signal output terminal for temperature measurement(OVEN).</p> <p>"H" level (GND) : Thermistor OPEN timing. "L" level (-5V) : Temperature measuring timing.(Convection cooking)</p>
25	INT1	IN	<p>Signal to synchronize LSI with commercial power source frequency.</p> <p>This is the basic timing for all real time processing of LSI.</p> 
26	P40	IN	Connected to GND.
27	RST	IN	<p>Auto clear terminal.</p> <p>Signal is input to reset the LSI to the initial state when power is applied. Temporarily set to "L" level the moment power is applied, at this time the LSI is reset. Thereafter set at "H" level.</p>
28/29	XCIN/XCOUT	OUT	Terminal not used.
30	XIN	IN	<p>Internal clock oscillation frequency setting input.</p> <p>The internal clock frequency is set by inserting the ceramic filter oscillation circuit with respect to XOUT terminal.</p>
31	XOUT	OUT	<p>Internal clock oscillation frequency control output.</p> <p>Output to control oscillation input of XIN.</p>
32	VSS	IN	<p>Power source voltage: -5V.</p> <p>VC voltage of power source circuit input.</p>
33	P27	IN	<p>Signal coming from touch key.</p> <p>When any one of G-1 line keys on key matrix is touched, a corresponding signal from P10 - P17 will be input into P27. When no key is touched, the signal is held at "L" level.</p>
34	P26	IN	<p>Signal similar to P27.</p> <p>When any one of G-2 line key on key matrix is touched, a corresponding signal will be input into P26.</p>
35	P25	IN	<p>Signal similar to P27.</p> <p>When any one of G-3 line key on key matrix is touched, a corresponding signal will be input into P25.</p>
36	P24	IN	<p>Signal similar to P27.</p> <p>When any one of G-4 line key on key matrix is touched, a corresponding signal will be input into P24.</p>

Pin No.	Signal	I/O	Description																																								
37	P23	OUT	<p>Segment data signals. The relation between signals and indicators are as follows:</p> <table border="0"> <tr> <td><u>Signal</u></td> <td><u>Segment</u></td> <td><u>Signal</u></td> <td><u>Segment</u></td> <td><u>Signal</u></td> <td><u>Segment</u></td> <td><u>Signal</u></td> <td><u>Segment</u></td> </tr> <tr> <td>P23</td> <td>P1</td> <td>P17</td> <td>P5</td> <td>P13</td> <td>P9</td> <td>P07</td> <td>P13</td> </tr> <tr> <td>P22</td> <td>P2</td> <td>P16</td> <td>P6</td> <td>P12</td> <td>P10</td> <td>P06</td> <td>P14</td> </tr> <tr> <td>P21</td> <td>P3</td> <td>P15</td> <td>P7</td> <td>P11</td> <td>P11</td> <td>P05</td> <td>P15</td> </tr> <tr> <td>P20</td> <td>P4</td> <td>P14</td> <td>P8</td> <td>P10</td> <td>P12</td> <td>P04</td> <td>P16</td> </tr> </table>	<u>Signal</u>	<u>Segment</u>	<u>Signal</u>	<u>Segment</u>	<u>Signal</u>	<u>Segment</u>	<u>Signal</u>	<u>Segment</u>	P23	P1	P17	P5	P13	P9	P07	P13	P22	P2	P16	P6	P12	P10	P06	P14	P21	P3	P15	P7	P11	P11	P05	P15	P20	P4	P14	P8	P10	P12	P04	P16
<u>Signal</u>	<u>Segment</u>	<u>Signal</u>	<u>Segment</u>	<u>Signal</u>	<u>Segment</u>	<u>Signal</u>	<u>Segment</u>																																				
P23	P1	P17	P5	P13	P9	P07	P13																																				
P22	P2	P16	P6	P12	P10	P06	P14																																				
P21	P3	P15	P7	P11	P11	P05	P15																																				
P20	P4	P14	P8	P10	P12	P04	P16																																				
38-40	P22-P20	OUT	<p>Segment data signal. Signal similar to P23.</p>																																								
41	P17	OUT	<p>Segment data signal. Signal similar to P23. Key strobe signal. Signal applied to touch-key section. A pulse signal is input to P24-P27 terminal while one of G-12 line keys on key matrix is touched.</p>																																								
42	P16	OUT	<p>Segment data signal. Signal similar to P23. Key strobe signal. Signal applied to touch-key section. A pulse signal is input to P24-P27 terminal while one of G-11 line keys on key matrix is touched.</p>																																								
43	P15	OUT	<p>Segment data signal. Signal similar to P23. Key strobe signal. Signal applied to touch-key section. A pulse signal is input to P24-P27 terminal while one of G-10 line keys on key matrix is touched.</p>																																								
44	P14	OUT	<p>Segment data signal. Signal similar to P23. Key strobe signal. Signal applied to touch-key section. A pulse signal is input to P24-P27 terminal while one of G-9 line keys on key matrix is touched.</p>																																								
45	P13	OUT	<p>Segment data signal. Signal similar to P23. Key strobe signal. Signal applied to touch-key section. A pulse signal is input to P24-P27 terminal while one of G-8 line keys on key matrix is touched.</p>																																								
46	P12	OUT	<p>Segment data signal. Signal similar to P23. Key strobe signal. Signal applied to touch-key section. A pulse signal is input to P24-P27 terminal while one of G-7 line keys on key matrix is touched.</p>																																								
47	P11	OUT	<p>Segment data signal. Signal similar to P23. Key strobe signal. Signal applied to touch-key section. A pulse signal is input to P24-P27 terminal while one of G-6 line keys on key matrix is touched.</p>																																								
48	P10	OUT	<p>Segment data signal. Signal similar to P23. Key strobe signal. Signal applied to touch-key section. A pulse signal is input to P24-P27 terminal while one of G-5 line keys on key matrix is touched.</p>																																								
49-53	P07-P03	OUT	<p>Segment data signal. Signal similar to P23.</p>																																								
54-56	P02-P00	OUT	<p>Digit selection signal. Signal similar to P55.</p>																																								
57-59	P37-P35	OUT	<p>Digit selection signal. Signal similar to P55.</p>																																								
60-64	P34-P30	OUT	Used for initial balancing of the bridge circuit (absolute humidity sensor).																																								

ABSOLUTE HUMIDITY SENSOR CIRCUIT

(1) Structure of Absolute Humidity Sensor

The absolute humidity sensor includes two thermistors as shown in the illustration. One thermistor is housed in the closed vessel filled with dry air while another in the open vessel. Each sensor is provided with the protective cover made of metal mesh to be protected from the external airflow.

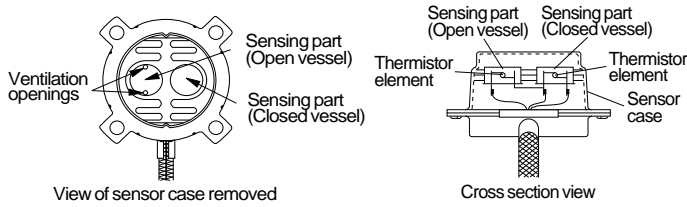

(2) Operational Principle of Absolute Humidity Sensor

The figure below shows the basic structure of an absolute humidity sensor. A bridge circuit is formed by two thermistors and two resistors (R1 and R2). The output of the bridge circuit is to be amplified by the operational amplifier.

Each thermistor is supplied with a current to keep it heated at about 150°C (302°F), the resultant heat is dissipated in the air and if the two thermistors are placed in different humidity conditions they show different degrees of heat conductivity leading to a potential difference between them causing an output voltage from the bridge circuit, the intensity of which is increased as the absolute humidity of the air increases. Since the output is very minute, it is amplified by the operational amplifier.

Each thermistor is supplied with a current to keep it heated at about 150°C (302°F), the resultant heat is dissipated in the air and if the two thermistors are placed in different humidity conditions they show different degrees of heat conductivity leading to a potential difference between them causing an output voltage from the bridge circuit, the intensity of which is increased as the absolute humidity of the air increases. Since the output is very minute, it is amplified by the operational amplifier.

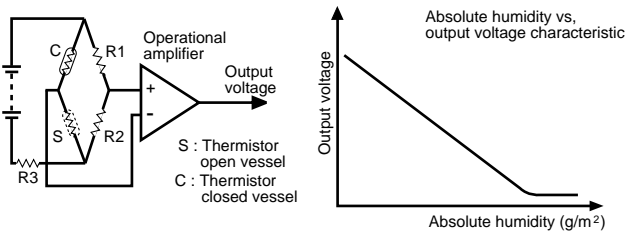

(3) Detector Circuit of Absolute Humidity Sensor Circuit

This detector circuit is used to detect the output voltage of the absolute humidity circuit to allow the LSI to control sensor cooking of the unit. When the unit is set in the sensor cooking mode, 16 seconds clearing cycle occurs than the detector circuit starts to function and the LSI observes the initial voltage available at its AN6 terminal.

With this voltage given, the switches SW1 to SW5 in the LSI are turned on in such a way as to change the resistance values in parallel with R50-1. Changing the resistance values results in that there is the same potential at both F-3 terminal of the absolute humidity sensor and AN7 terminal of the LSI. The voltage of AN6 terminal will indicate about -2.5V. This initial balancing is set up about 16 seconds after the unit is put in the Sensor Cooking mode. As the sensor cooking proceeds, the food is heated to generate moisture by which the resistance balance the bridge circuit is deviated to increase the voltage available at AN6 terminal of the LSI.

Then the LSI observes that voltage at AN6 terminal and compares it with its initial value, and when the comparison rate reaches the preset value (fixed for each menu to be cooked), the LSI causes the unit to stop sensor cooking; thereafter, the unit goes in the next operation automatically.

When the LSI starts to detect the initial voltage at AN6 terminal 16 seconds after the unit has been put in the Sensor Cooking mode, if it is not possible to balance, of the bridge circuit due to disconnection of the absolute humidity sensor, ERROR will appear on the display and the cooking is stopped.

1) Absolute humidity sensor circuit

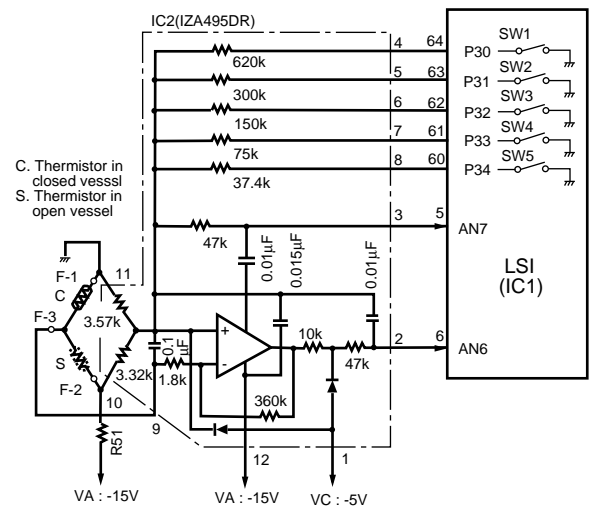

TOUCH CONTROL PANEL SERVICING

1. Precautions for Handling Electronic Components

This unit uses CMOS LSI in the integral part of the circuits. When handling these parts, the following precautions should be strictly followed. CMOS LSI have extremely high impedance at its input and output terminals. For this reason, it is easily influenced by the surrounding high voltage power source, static electricity charge in clothes, etc. and sometimes it is not fully protected by the built-in protection circuit. In order to protect CMOS LSI.

- 1) When storing and transporting, thoroughly wrap them in aluminium foil. Also wrap all PW boards containing them in aluminium foil.
- 2) When soldering, ground the technician as shown in the figure and use grounded soldering iron and work table.

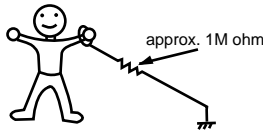

2. Shapes of Electronic Components

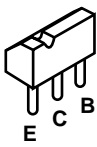

Transistor
2SB910M

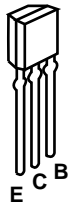

Transistor
DTA123ES
KRA101M
KRA223M
KRC243M

3. Servicing of Touch Control Panel

We describe the procedures to permit servicing of the touch control panel of the microwave oven and the precautions you must take when doing so. To perform the servicing, power to the touch control panel is available either from the power line of the oven itself or from an external power source.

(1) Servicing the touch control panel with power supply of the oven:

CAUTION:

THE HIGH VOLTAGE TRANSFORMER OF THE MICROWAVE OVEN IS STILL LIVE DURING SERVICING AND PRESENTS A HAZARD.

Therefore, before checking the performance of the touch control panel,

- 1) Disconnect the power supply cord, and then remove outer case.
- 2) Open the door and block it open.
- 3) Discharge high voltage capacitor.
- 4) Disconnect the leads to the primary of the power transformer.
- 5) Ensure that these leads remain isolated from other components and oven chassis by using insulation tape.
- 6) After that procedure, re-connect the power supply cord. After checking the performance of the touch control panel,
 - 1) Disconnect the power supply cord.
 - 2) Open the door and block it open.
 - 3) Re-connect the leads to the primary of the power transformer.
 - 4) Re-install the outer case (cabinet).

5) Re-connect the power supply cord after the outer case is installed.

6) Run the oven and check all functions.

- A. On some models, the power supply cord between the touch control panel and the oven itself is so short that the two can't be separated. For those models, check and repair all the controls (sensor-related ones included) of the touch control panel while keeping it connected to the oven.
- B. On some models, the power supply cord between the touch control panel and the oven proper is long enough that they may be separated from each other. For those models, it is possible to check and repair the controls of the touch control panel while keeping it apart from the oven proper; in this case you must short both ends of the door sensing switch (on PWB) of the touch control panel with a jumper, which activates an operational state that is equivalent to the oven door being closed. As for the sensor-related controls of the touch control panel, checking them is possible if dummy resistor(s) with resistance equal to that of the controls are used.

(2) Servicing the touch control panel with power supply from an external power source:

Disconnect the touch control panel completely from the oven proper, and short both ends of the door sensing switch (on PWB) of the touch control panel, which activates an operational state that is equivalent to the oven door being closed. Connect an external power source to the power input terminal of the touch control panel, then it is possible to check and repair the controls of the touch control panel it is also possible to check the sensor-related controls of the touch control panel by using the dummy resistor(s).

4. Servicing Tools

Tools required to service the touch control panel assembly.

- 1) Soldering iron: 30W
(It is recommended to use a soldering iron with a grounding terminal.)
- 2) Oscilloscope: Single beam, frequency range: DC-10MHz type or more advanced model.
- 3) Others: Hand tools

5. Other Precautions

- 1) Before turning on the power source of the control unit, remove the aluminium foil applied for preventing static electricity.
- 2) Connect the connectors of the key unit to the control unit being sure that the lead wires are not twisted.
- 3) After aluminium foil is removed, be careful that abnormal voltage due to static electricity etc. is not applied to the input or output terminals.
- 4) Attach connectors, electrolytic capacitors, etc. to PWB, making sure that all connections are tight.
- 5) Be sure to use specified components where high precision is required.

COMPONENT REPLACEMENT AND ADJUSTMENT PROCEDURE

WARNING AGAINST HIGH VOLTAGE:

Microwave ovens contain circuitry capable of producing very high voltage and current, contact with following parts may result in severe, possibly fatal, electric shock.

(Example)

High Voltage Capacitor, Power Transformer, Magnetron, High Voltage Rectifier Assembly, High Voltage Harness etc..

WARNING: Avoid possible exposure to microwave energy. Please follow the instructions below before operating the oven.

1. Disconnect the power supply cord.
2. Make sure that a definite "click" can be heard when the microwave oven door is unlatched. (Hold the door in a closed position with one hand, then push the door open button with the other, this causes the latch leads to rise, it is then possible to hear a "click" as the door switches operate.)
3. Visually check the door and cavity face plate for damage (dents, cracks, signs of arcing etc.).
1. Door does not close firmly.
2. Door hinge, support or latch hook is damaged.
3. The door gasket or seal is damaged.
4. The door is bent or warped.
5. There are defective parts in the door interlock system.
6. There are defective parts in the microwave generating and transmission assembly.
7. There is visible damage to the oven.

Carry out any remedial work that is necessary before operating the oven.

Do not operate the oven if any of the following conditions exist;

Do not operate the oven:

1. Without the RF gasket (Magnetron).
2. If the wave guide or oven cavity are not intact.
3. If the door is not closed.
4. If the outer case (cabinet) is not fitted.

WARNING FOR WIRING

To prevent an electric shock, take the following precautions.

1. Before wiring,
 - 1) Disconnect the power supply cord.
 - 2) Open the door block it open.
 - 3) Discharge the high voltage capacitor and wait for 60 seconds.
2. Don't let the wire leads touch to the following parts:
 - 1) High voltage parts:
Magnetron, High voltage transformer, High voltage capacitor and High voltage rectifier assembly.
 - 2) Hot parts:
Oven lamp, Magnetron, High voltage transformer, Oven cavity and Heating element.
- 3) Sharp edge:
Bottom plate, Oven cavity, Waveguide flange, Chassis support and other metallic plate.
- 4) Moveable parts (to prevent a fault)
Fan blade, Fan motor, Switch, Switch lever, Open button, Convection motor, Convection fan, Convection fan belt, Pulley, Turntable motor, Damper motor, Damper door assembly.
3. Do not catch the wire leads in the outer case cabinet.
4. Insert the positive lock connector until its pin is locked and make sure that the wire leads do not come off even if the wire leads are pulled.
5. To prevent an error function, connect the wire leads correctly, referring to the Pictorial Diagram.

Please refer to 'OVEN PARTS, CABINET PARTS, CONTROL PANEL PARTS, DOOR PARTS', when carrying out any of the following removal procedures:

OUTER CASE REMOVAL

To remove the outer case, proceed as follows.

1. Disconnect the power supply cord.
2. Open the oven door and block it open.
3. Remove the two (2) screws from the lower portion of the rear cabinet using a T20H Torx type or GTXH20-100 screw driver.
4. Remove the remaining two (2) screws from rear and one (1) screw along the right side of outer case.
5. Slide the entire outer case back out about 1 inch (3 cm) to free it from retaining clips on the cavity face plate.
6. Lift entire outer case from the unit.

- CAUTION:** 1. DISCONNECT OVEN FROM POWER SUPPLY BEFORE REMOVING OUTER CASE.
2. DISCHARGE THE HIGH VOLTAGE CAPACITOR BEFORE TOUCHING ANY OVEN COMPONENTS OR WIRING.

NOTE: When replacing the outer case, the 2 special Torx screws must be reinstalled in the same locations.

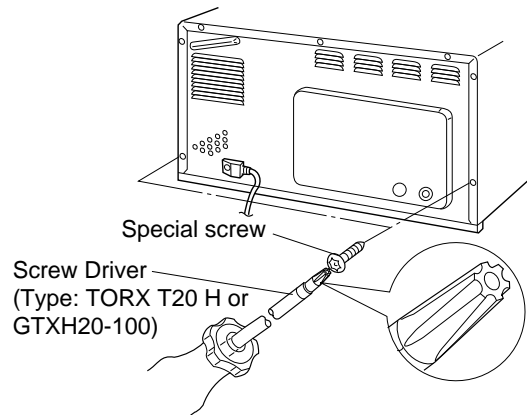

POWER TRANSFORMER REMOVAL

1. Disconnect the power supply cord and then remove outer case.
2. Open the oven door and block it open.
3. Discharge high voltage capacitor.
4. Disconnect filament leads of transformer from the magnetron and capacitor.
5. Disconnect high voltage lead of capacitor from the transformer.
6. Disconnect wire leads from the transformer.
7. Remove two (2) screws holding the transformer to the base cabinet.
3. Make sure the transformer is mounted correctly to the corners underneath those tabs.
4. After re-installing the transformer, secure the transformer with two screws to the base cabinet, one is with outer tooth washer and the other is without outer-tooth washer.
5. Re-connect the wire leads (primary and high voltage) and high voltage lead to the transformer and filament leads of transformer to the magnetron and capacitor, referring to the "Pictorial Diagram".
6. Re-install the outer case and check that the oven is operating properly.

Re-install

1. Rest the transformer on the base cabinet with its primary terminals toward rear cabinet.
2. Insert the two edges of the transformer into two metal tabs of the base cabinet.

NOTE HOT (ORANGE) WIRE MUST BE CONNECTED TO THE POWER TRANSFORMER TERMINAL NEAREST TO THE TRANSFORMER MOUNTING SCREW.

MAGNETRON REMOVAL

1. Disconnect the power supply cord and then remove outer case.
2. Open the oven door and block it open.
3. Discharge high voltage capacitor.
4. Disconnect filament lead of transformer from magnetron.
5. Disconnect high voltage wire lead from magnetron.
6. Carefully remove four (4) mounting screws hold the magnetron to waveguide, when removing the screws holding the magnetron to prevent it from falling.
7. Remove the magnetron from the unit with care so the magnetron tube should not hit by any metal object around the tube.

CAUTION: WHEN REPLACING THE MAGNETRON, BE SURE THE R.F. GASKET IS IN PLACE AND THE MAGNETRON MOUNTING SCREWS ARE TIGHTENED SECURELY.

HIGH VOLTAGE RECTIFIER ASSEMBLY REMOVAL

1. Disconnect the power supply cord and then remove outer case.
2. Open the oven door and block it open.
3. Discharge high voltage capacitor.
4. Remove one (1) screw holding the rectifier assembly to the capacitor holder.
5. Disconnect the rectifier assembly from the capacitor and magnetron.

CAUTION: WHEN REPLACING THE SILICON RECTIFIER ASSEMBLY, THE GROUND SIDE TERMINAL MUST BE SECURED FIRMLY WITH A GROUNDING SCREW.

HIGH VOLTAGE CAPACITOR REMOVAL

1. Disconnect the power supply cord and then remove outer case.
2. Open the oven door and block it open.
3. Discharge high voltage capacitor.
4. Disconnect the high voltage wire leads and rectifier assembly from high voltage capacitor and magnetron.
5. Disconnect filament lead of transformer from high voltage capacitor.
6. Disconnect high voltage wire lead of capacitor from transformer.

7. Remove one (1) screw and washer holding the rectifier from the capacitor holder.
8. Remove one (1) screw holding the capacitor holder to

- the rear cabinet.
9. Remove the capacitor from the holder.

POSITIVE LOCK® CONNECTOR (NO-CASE TYPE) REMOVAL

1. Disconnect the power supply cord and then remove outer case.
2. Open the oven door and block it open.
3. Discharge high voltage capacitor.
4. Push the lever of positive lock® connector.
5. Pull down on the positive lock® connector.

CAUTION: WHEN YOU CONNECTING THE POSITIVE LOCK® CONNECTORS TO THE TERMINALS, INSTALL THE POSITIVE LOCK® SO THAT THE LEVER FACES YOU.

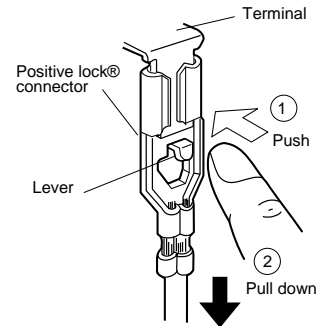

Figure C-2. Positive lock® connector

CONVECTION MOTOR REMOVAL

1. Disconnect the power supply cord and then remove outer case.
2. Open the oven door and block it open.
3. Discharge high voltage capacitor.
4. Disconnect wire leads from the convection motor.
5. Remove the convection fan belt.
6. Remove two (2) screws holding the convection motor

- mounting angle to the heater duct and base cabinet.
7. Take out the convection motor assembly from the unit. The convection motor assembly is now free.
8. Remove two (2) screws and nuts holding the motor to mounting angle.
9. Remove pulley (M) from the motor shaft. Convection motor is now free.

TURNTABLE MOTOR REMOVAL

1. Disconnect the power supply cord.
2. Remove the turntable tray, and the turntable support out of the oven cavity.
3. Turn the oven upside down and remove one (1) screw holding the turntable motor cover to the base plate and take off the turntable motor cover.

4. Disconnect wire lead from the turntable motor.
5. Remove the two (2) screws holding the turntable motor and coupling mounting plate to the oven cavity bottom.
6. Turntable motor, Coupling mounting plate and Thermal protection plate bottom will be free.

DAMPER ASSEMBLY REMOVAL

1. Disconnect the power supply cord and then remove outer case.
2. Open the oven door and block it open.
3. Discharge high voltage capacitor.
4. Disconnect wire leads from damper motor and damper switch.
5. Remove two (2) oven side screws holding damper motor

- angle to thermal protection plate (right).
6. Damper assembly is free.
7. Remove one (1) screw holding damper motor to damper motor angle and one (1) screw holding damper switch to damper motor angle.
8. Damper motor and switch are free.

OVEN LAMP AND LAMP SOCKET REMOVAL

1. Disconnect the power supply cord and then remove outer case.
2. Open the oven door and block it open.
3. Discharge high voltage capacitor.
4. Bend the tab of the air guide holding the lamp socket.
5. Lift up the oven lamp socket.
6. Pull the wire leads from the oven lamp socket by pushing the terminal hole of the oven lamp socket with the small flat type screw driver.
7. Now, the oven lamp socket is free.

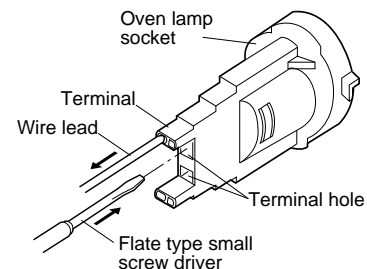

Figure C-3. Oven lamp socket

HEATER UNIT ASSEMBLY REMOVAL

(HEATING ELEMENT/CONVECTION FAN/CONVECTION MOTOR/THERMISTOR)

THERMISTOR REMOVAL

1. Disconnect the power supply cord and then remove outer case.
2. Open the oven door and block it open.
3. Discharge high voltage capacitor.
4. Disconnect wire leads from H.V. capacitor and remove four (4) screws holding rear cabinet to bottom plate and three (3) screws holding to heater unit assembly and two (2) screws holding steam duct to top of oven cavity. Disconnect wire leads from power supply cord terminals.
5. Disconnect wire leads from thermistor. Remove two (2) screws from thermistor.
6. Disconnect wire leads from convection motor, thermal cut-out and heater element.
7. Remove nine (9) screws holding heater duct to the oven cavity.
8. Remove two (2) screws holding heater duct to base cabinet. Release two (2) snap bands holding wire harness to the thermal cover (convection).
9. The heater unit is now free.

HEATING ELEMENT REMOVAL

10. Remove two (2) screws holding heating element to heater duct.
11. Loosen two (2) screws holding holders to heater duct and take heating element out of heating element holders.
12. Heating element is free.

NOTE: After installed the heating element completely, bent top of the heating element holder to inside using by long nose pliers as shown following illustration.

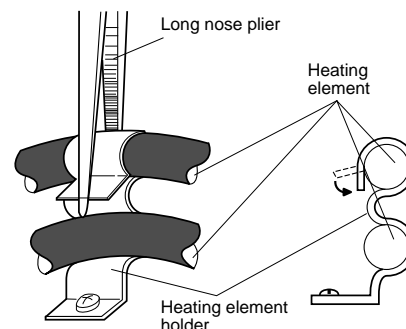

CONTROL PANEL ASSEMBLY AND CONTROL UNIT REMOVAL

To remove the control panel, procedure as follows:

1. Disconnect the power supply cord and then remove outer case.
2. Open the oven door and block it open.
3. Discharge high voltage capacitor.
4. Disconnect connector CN-A, CN-E and CN-F from the control unit.
5. Disconnect the wire leads from the relays RY1, RY2 and RY3.
6. Remove one (1) screw holding the control panel back plate to the chassis support.
7. Remove two (2) screws holding the bottom edge of the back plate to the cabinet base.
8. Remove one (1) screw holding the back plate to the oven cavity flange.
9. Lift up and pull the control panel assembly forward.

Replacement of individual component is as follows;

CONTROL UNIT AND KEY UNIT

1. Disconnect the wire connector from the control unit.
2. Remove the four (4) screws holding the panel frame to the back plate.
3. Separate the panel frame and back plate.
4. Remove the three (3) screws holding the control unit to the panel frame.
5. Lift up the control unit and disconnect the key connector from the control unit.
6. Now, the control unit and frame assembly are separated.

NOTE:

1. Before attaching a new key unit, remove remaining adhesive on the control panel frame surfaces completely with a soft cloth soaked in alcohol.
2. When attaching the key unit to the control panel frame, adjust the lower edge and right edge of the key unit to the correct position of the control panel frame.
3. Stick the key unit firmly to the control panel frame by rubbing with soft cloth not to scratch.

FAN MOTOR REMOVAL

1. Disconnect the power supply cord and then remove outer case.
2. Open the oven door and block it open.
3. Discharge high voltage capacitor.
4. Disconnect the wire leads from the fan motor.
5. Remove one (1) screw holding the fan motor grounding wire to the air guide (Right).
6. Remove three (3) screws holding the chassis support to the rear cabinet, waveguide and control panel back plate.
7. Remove the chassis support from the oven.
8. Remove one (1) screw holding the magnetron air guide

- to the waveguide.
9. Remove the magnetron air guide from the waveguide.
10. Disconnect wire leads from the fan motor.
11. Release the main harness from the hole of the fan duct.
12. Release the thermistor harness from the hole of the fan duct.
13. Release one (1) tab holding the fan duct to the rear cabinet.
14. Release one (1) tab holding the fan duct to the air guide (Right).
15. Remove the fan duct assembly from the oven.

16. Remove the fan blade from the fan motor shaft according the following procedure.
17. Hold the edge of the rotor of the fan motor by using a pair of groove joint pliers.

CAUTION:

- * **Make sure that no metal pieces enter the gap between the rotor and the stator of the fan motor because the rotor is easily shaven by pliers and metal pieces may be produced.**
 - * **Do not touch the pliers to the coil of the fan motor because the coil may be cut or injured.**
 - * **Do not disfigure the bracket by touching with the pliers.**
18. Remove the fan blade from the shaft of the fan motor by pulling and rotating the fan blade with your hand.
 19. Now, the fan blade will be free.

CAUTION:

- * **Do not reuse the removed fan blade because the hole (for shaft) may be larger than normal.**
20. Remove the two (2) screws and nuts holding the fan motor to the fan duct.
 21. Now, the fan motor is free.

INSTALLATION

1. Install the fan motor to the fan duct with the two (2) screws and nuts.
2. Install the fan blade to the fan motor shaft according the following procedure.

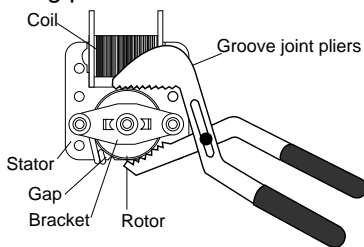
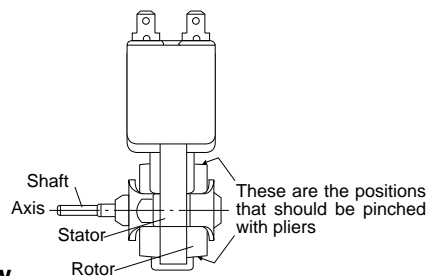
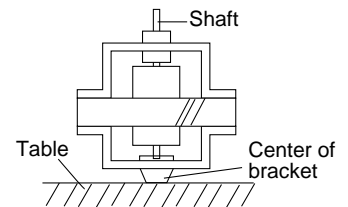
**Rear View****Side View**

3. Hold the center of the bracket which supports the shaft of the fan motor on the flat table.
4. Apply the screw lock tight into the hole (for shaft) of the fan blade.
5. Install the fan blade to the shaft of fan motor by pushing the fan blade with a small, light weight, ball peen hammer or rubber mallet.

CAUTION:

- * **Do not hit the fan blade strongly when installed because the bracket may be disfigured.**
 - * **Make sure that the fan blade rotates smooth after installation.**
 - * **Make sure that the axis of the shaft is not slanted.**
6. Reset the fan duct assembly to its place.
 7. Install the tabs of fan duct to the rear cabinet and air guide.
 8. Install the magnetron air guide with the one (1) screw.
 9. Reinstall the main harness and thermistor harness to each hole of the fan duct.
 10. Reinstall the chassis support to the control panel back plate, waveguide and rear cabinet with the three (3) screws.
 11. Re-connect the wire leads to the fan motor, referring to the pictorial diagram.
 12. Re-install the fan motor grounding wire to the air guide (Right) with one (1) screw.

DOOR SENSING SWITCH/SECONDARY INTERLOCK SWITCH AND MONITOR SWITCH REMOVAL

1. Disconnect the power supply cord and then remove outer case.
2. Open the oven door and block it open.
3. Discharge high voltage capacitor.
4. Remove the control panel assembly, refer to "Control Panel Removal".
5. Disconnect wire leads from each of the switches and fuse holder.
6. Remove two (2) screws holding latch hook to oven flange.
7. Remove latch hook assembly from oven flange.
8. Push outward on the one (1) stopper tabs holding each of switches place.
9. Switch is now free.

At this time switch lever will be free, do not lose it.

Re-install

1. Re-install switch lever and each interlock switch in its place. The secondary interlock switch is in the lower position and the door sensing switch is in the upper position and the monitor switch is in the middle position.
2. Re-connect wire leads to each switches and fuse holder. Refer to pictorial diagram.
3. Secure latch hook (with two (2) mounting screws) to oven flange.
4. Make sure that the monitor switch is operating properly and check continuity of the monitor circuit. Refer to chapter "Test Procedure" and Adjustment procedure.

DOOR SENSING SWITCH/SECONDARY INTERLOCK SWITCH AND MONITOR SWITCH ADJUSTMENT

1. Disconnect the power supply cord and then remove outer case.
2. Open the oven door and block it open.

3. Discharge high voltage capacitor.
If the door sensing switch, secondary interlock switch and monitor switch do not operate properly due to a

misadjustment, the following adjustment should be made.

- Loosen the two (2) screws holding latch hook to the oven cavity front flange.
- With door closed, adjust latch hook by moving it back and forth, and up and down. In and out play of the door allowed by the latch hook should be less than 0.5mm.
- Secure the screws with washers firmly.

After adjustment, check the following.

- In and out play of door remains less than 0.5mm at the latched position.
- The door sensing switch and secondary interlock switch interrupt the circuit before the door can be opened.
- Monitor switch contacts close when door is opened.
- Re-install outer case and check for microwave leakage around door with an approved microwave survey meter. (Refer to Microwave Measurement Procedure.)

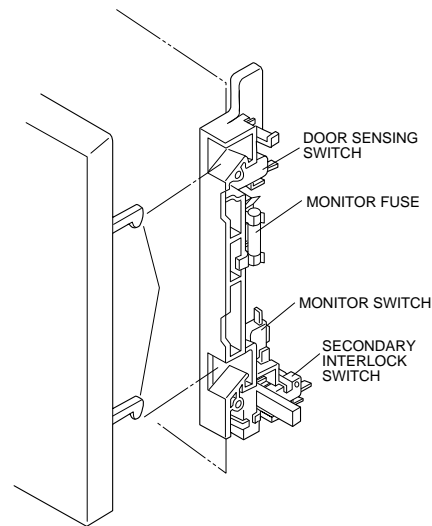

Figure C-4. Latch Switch Adjustments

DOOR REPLACEMENT AND ADJUSTMENT

REMOVAL

- Disconnect the power supply cord and then remove outer case.
- Open the oven door and block it open.
- Discharge high voltage capacitor.
- Remove turntable tray and turntable support from oven cavity.
- Remove three (3) screws holding lower oven hinge.
- Remove the lower oven hinge from oven cavity bottom flange.
- Remove door assembly from upper oven hinge on the oven.
- Door assembly is now free.

Note: When the individual parts are replaced, refer to "Door Disassembly".

- On re-installing door, insert the upper oven hinge into the door hinge pin. Then while holding door in place.
- Make sure the door is parallel with oven face lines (left and upper side lines) and door latch heads pass through latch holes correctly.
- Insert the lower oven hinge into oven cavity bottom flange and then engaged the door hinge pin. Then secure the lower oven hinge firmly with three (3) mounting screws.

Note: After any service to the door;

(A) Make sure that door sensing switch and secondary interlock switch are operating properly. (Refer to chapter "Test Procedures").

(B) An approved microwave survey meter should be used to assure compliance with proper microwave radiation emission limitation standards.

DOOR ADJUSTMENT

The door can be adjusted by keeping screws of each hinge loose.

After adjustment, make sure of the following :

- Door latch heads smoothly catch latch hook through

- latch holes and that latch head goes through center of latch hole.
- Deviation of door alignment from horizontal line of cavity face plate is to be less than 1.0mm.
- Door is positioned with its face pressed toward cavity face plate.
- Re-install outer case and check for microwave leakage around door with an approved microwave survey meter. (Refer to Microwave Measurement Procedure.)

Note: The door on a microwave oven is designed to act as an electronic seal preventing the leakage of microwave energy from oven cavity during cook cycle. This function does not require that door be airtight, moisture (condensation)-tight or light-tight. Therefore, occasional appearance of moisture, light or sensing of gentle warm air movement around oven door is not abnormal and do not of themselves indicate a leakage of microwave energy from oven cavity. If such were the case, your oven could not be equipped with a vent, the very purpose of which is to exhaust the vapor-laden air from the oven cavity.

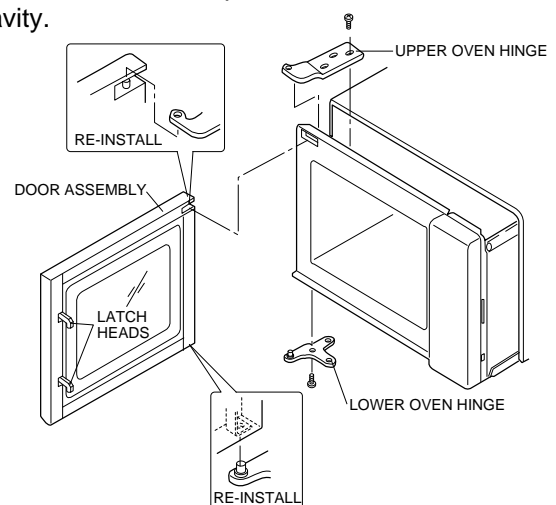

Figure C-5. Door Replacement and adjustment

DOOR DISASSEMBLY

Remove door assembly, refer to "Door Replacement".

Replacement of door components are as follows:

CHOKE COVER

1. Place door assembly on a soft cloth with latches facing up.

Note: As the engaging part of choke cover and door panel are provided at several places, do not force any particular part.

2. Insert an putty knife (thickness of about 0.5mm) into the gap between the choke cover and corner portion of door panel as shown Figure C-6 to free engaging parts.
3. Lift up choke cover.
4. Now choke cover is free from door panel.

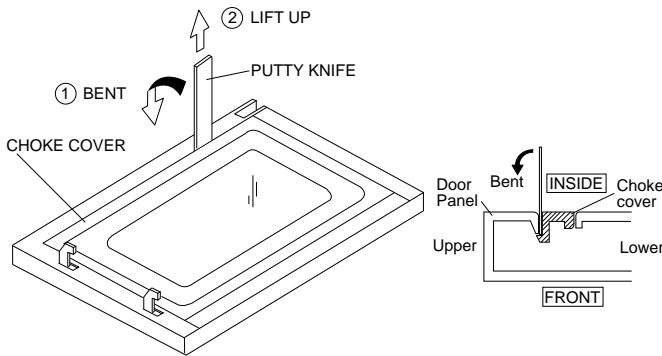

Figure C-6. Door Disassembly

DOOR PANEL

5. Remove the twelve (12) screws holding the door panel to the door frame.

NOTE: The one (1) screw of the twelve (12) screws also holds the earth terminal of the door decoration to the door frame.

6. Remove the door panel from the door frame. Now the door panel is free.

DOOR GLASS

7. Remove the two (2) screws holding the thermal plate U to the door frame.
8. Remove the two (2) screws holding the thermal plate R to the door frame.
9. Remove the thermal plate U and the thermal plate R from the door frame.
10. Slide the door glass leftward.
11. Slide the door glass upward.
12. Remove the door glass from the door frame. Now the door glass is free.

DOOR DECORATION AND DOOR FRAME

13. Straighten all tabs of the door decoration.
14. Remove the door decoration from the door frame.
15. Now the door decoration and door frame are free.

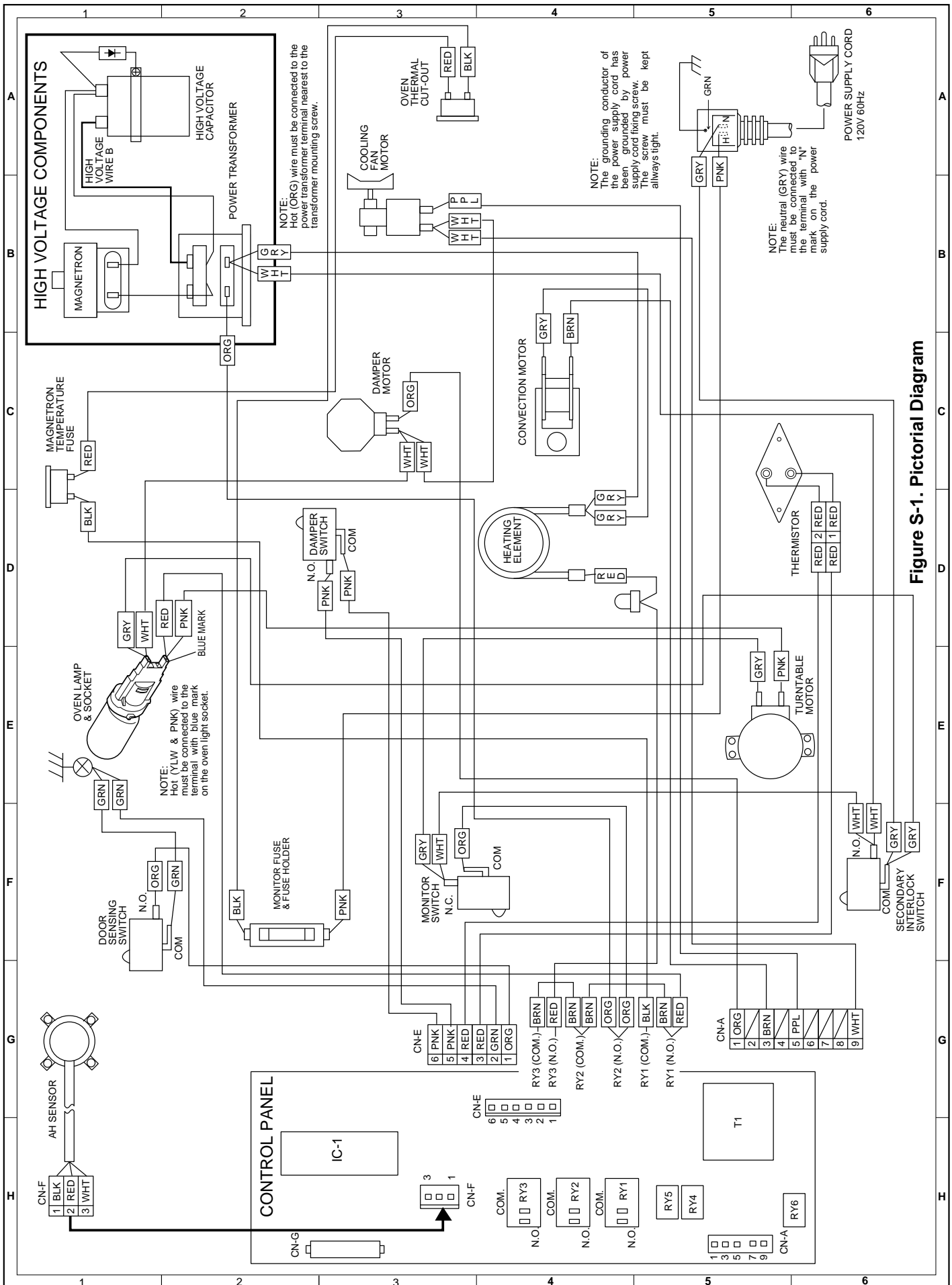

Figure S-1. Pictorial Diagram

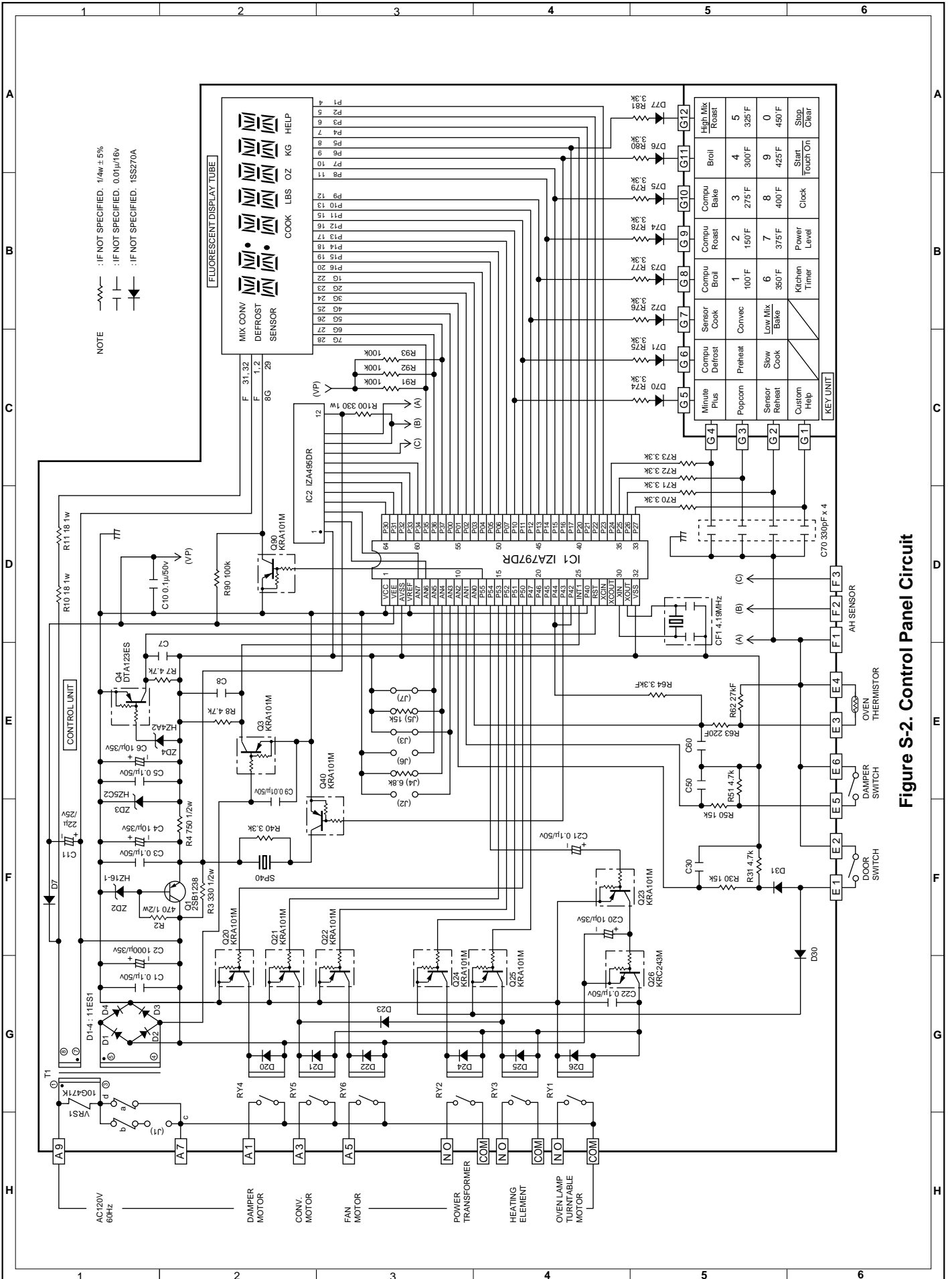

Figure S-2. Control Panel Circuit

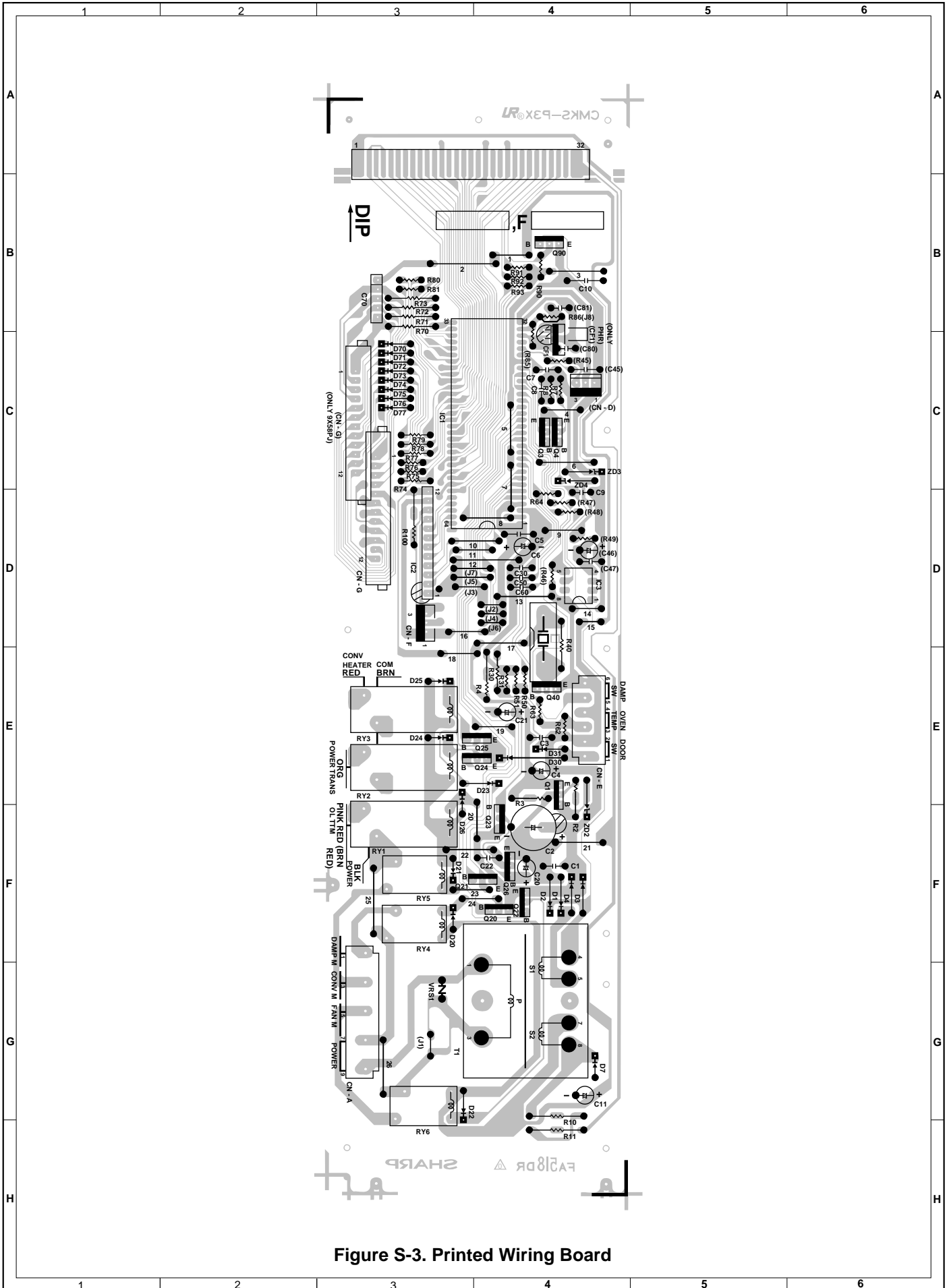

Figure S-3. Printed Wiring Board

PARTS LIST

**Note: The parts marked "Δ" may cause undue microwave exposure.
The parts marked "*" are used in voltage more than 250V.**

REF. NO.	PART NO.	DESCRIPTION	Q'TY	CODE
ELECTRICAL PARTS				
1- 1	FACCDAA075WRE0	Power supply cord	1	AN
1- 1	FACCDAA048WRE0	Power supply cord (Interchangeable)	1	AT
1- 2	FFS-BA012WRK0	Monitor fuse 20A and monitor switch (V-5220D-070) assembly	1	AH
1- 3	QFSHDA009WRE0	Fuse holder	1	AF
1- 4	QSW-MA131WRE0	Secondary interlock switch & door sensing switch	2	AG
1- 4	QSW-MA110WRE0	Secondary interlock switch & door sensing switch (Interchangeable)	2	AK
1- 5	FH-HZA041WRE0	Thermistor	1	AN
1- 6	QSW-MA110WRE0	Damper aswitch	1	AK
1- 7	QFS-TA013WRE0	Magnetron temperature fuse 150°C	1	AG
1- 8	RTHM-A085WRE0	Oven thermal cut-out 150°C	1	AL
1- 9	RMOTDA192WRE0	Damper motor	1	AS
1-10	RLMPTA071WRE0	Oven lamp	1	AK
1-11	QSOCLA021WRE0	Oven lamp socket	1	AG
1-13	RMOTEA283WRE0	Convection fan motor	1	AZ
1-14	RMOTEA300WRE0	Fan motor	1	AZ
1-15	RHET-A136WRE0	Heating element	1	AW
* 1-16	RTRN-A535WRE0	Power transformer	1	BL
* 1-16	RTRN-A527WRE0	Power transformer (Interchangeable)	1	BP
* 1-17	RC-QZA173WRE0	H.V.capacitor	1	AX
* 1-17	RC-QZA211WRE0	H.V.capacitor (Interchangeable)	1	AV
* 1-18	FH-DZA053WRK0	H.V.rectifier assembly	1	AP
Δ* 1-19	RV-MZA256WRE0	Magnetron	1	BL
1-20	RMOTDA222WRE0	Turntable motor	1	AY
1-21	FDTCTA183WRK0	AH sensor assembly	1	AY

CABINET PARTS

2- 1	GCABUA728WRP0	Outer case cabinet	1	BK
2- 2	TMAPCA763WRR0	Schematic diagram	1	AC
2- 3	FDAI-A198WRY0	Base cabinet	1	AM
2- 3-1	GCOVHA156WRP0	Turntable motor cover	1	AB
2- 3-2	XHTSD40P08RV0	Screw; 4mm x 8mm	1	AA
2- 4	GLEGPA019WRE0	Foot	4	AD
2- 5	GCABDA095WRW0	Rear cabinet	1	AH
2- 6	LHLDKA009WRF0	Cord holder	1	AG
2- 7	LBNDKA036WRP0	Capacitor holder	1	AG
Δ 2- 8	FHNG-A092WRM0	Oven hinge (Lower)	1	AF
Δ 2- 9	PHOK-A112WRF0	Latch hook	1	AM
2-10	MLEVPA231WRF0	Switch lever	1	AE

CONTROL PANEL PARTS

3- 1	CPWBFA748WRK0	Control unit	1	BU
3- 1A	QCNCMA227DRE0	5-pin connector(A)	1	AC
3- 1B	QCNCMA267DRE0	6-pin connector(E)	1	AC
3- 1C	QCNCMA237DRE0	3-pin connector(F)	1	AD
3- 1D	QCNCWA057DRE0	12-pin connector(G)	1	AF
3- 1E	RV-KXA077DRE0	Fluorescent display tube	1	AY
3- 1F	PCUSGA381WRP0	Cushion	2	AG
C1	RC-KZA087DRE0	Capacitor 0.1μF 50V	1	AA
C2	VCEAB31VW108M	Capacitor 1000μF 35V	1	AF
C3	RC-KZA087DRE0	Capacitor 0.1μF 50V	1	AA
C4	VCEAB31VW106M	Capacitor 10μF 35V	1	AA
C5	RC-KZA087DRE0	Capacitor 0.1μF 50V	1	AA
C6	VCEAB31VW106M	Capacitor 10μF 35V	1	AA
C7-8	VCKYD11CY103N	Capacitor 0.01μF 16V	2	AA
C9	VCTYF31HF103Z	Capacitor 0.01μF 50V	1	AB
C10	RC-KZA087DRE0	Capacitor 0.1μF 50V	1	AA
C11	VCEAB31EW226M	Capacitor 22μF 25V	1	AA
C20	VCEAB31VW106M	Capacitor 10μF 35V	1	AA
C21	VCEAB31HW104M	Capacitor 0.1μF 50V	1	AM
C22	RC-KZA087DRE0	Capacitor 0.1μF 50V	1	AA
C30	VCKYD11CY103N	Capacitor 0.01μF 16V	1	AA
C50	VCKYD11CY103N	Capacitor 0.01μF 16V	1	AA
C60	VCKYD11CY103N	Capacitor 0.01μF 16V	1	AA
C70	RMPTEA009DRE0	Capacitor array 330pF x 4	1	AE
CF1	RCRS-A035DRE0	Ceramic resonator (CST4.19MGW)	1	AG
D1-4	VHD11ESI///-1	Diode (11ESI)	4	AB
D7	VHD1SS270A/-1	Diode (1SS270ATA)	1	AA

REF. NO.	PART NO.	DESCRIPTION	Q'TY	CODE
D20-26	VHD1SS270A/-1	Diode (1SS270ATA)	7	AA
D30-31	VHD1SS270A/-1	Diode (1SS270ATA)	2	AA
D70-77	VHD1SS270A/-1	Diode (1SS270ATA)	8	AA
IC1	RH-IZA797DRE0	LSI	1	AX
IC2	RH-IZA495DRE0	IC	1	AL
Q1	VS2SB910MR/-4	Transistor (2SB910M)	1	AE
Q3	VSKRA101M//-3	Transistor (KRA101M)	1	AB
Q4	VSDTA123ES/-3	Transistor (DTA123E)	1	AA
Q20-23	VSKRA101M//-3	Transistor (KRA101M)	4	AB
Q24-25	VSKRA223M//-3	Transistor (KRA223M)	2	AB
Q26	VSKRC243M//-3	Transistor (KRC243M)	1	AB
Q40	VSKRA101M//-3	Transistor (KRA101M)	1	AB
Q90	VSKRA101M//-3	Transistor (KRA101M)	1	AB
R2	VRD-B12HF471J	Resistor 470 ohm 1/2W	1	AA
R3	VRD-B12HF331J	Resistor 330 ohm 1/2W	1	AA
R4	VRD-B12HF751J	Resistor 750 ohm 1/2W	1	AA
R7-8	VRD-B12EF472J	Resistor 4.7k ohm 1/4W	2	AA
R10-11	VRS-B13AA180J	Resistor 18 ohm 1W	2	AA
R30	VRD-B12EF153J	Resistor 15k ohm 1/4W	1	AA
R31	VRD-B12EF472J	Resistor 4.7k ohm 1/4W	1	AA
R40	VRD-B12EF332J	Resistor 3.3k ohm 1/4W	1	AA
R50	VRD-B12EF153J	Resistor 15k ohm 1/4W	1	AA
R51	VRD-B12EF472J	Resistor 4.7k ohm 1/4W	1	AA
R62	VRN-B12EK273F	Resistor 27k ohm(F) 1/4W	1	AA
R63	VRN-B12EK221F	Resistor 220 ohm(F) 1/4W	1	AB
R64	VRN-B12EK332F	Resistor 3.3k ohm(F) 1/4W	1	AA
R70-81	VRD-B12EF332J	Resistor 3.3k ohm 1/4W	12	AA
R90-93	VRD-B12EF104J	Resistor 100k ohm 1/4W	4	AA
R100	VRS-B13AA331J	Resistor 330 ohm 1W	1	AA
(J4)	VRD-B12EF682J	Resistor 6.8k ohm 1/4W	1	AA
(J5)	VRD-B12EF153J	Resistor 15k ohm 1/4W	1	AA
RY1-3	RRLY-A083DRE0	Relay (OMIF-S-118LM)	3	AK
RY4-6	RRLY-A078DRE0	Relay (OJ-SH-118LM)	3	AG
SP40	RALM-A014DRE0	Buzzer (PKM22EPT)	1	AG
T1	RTRNPA022DRE0	Transformer	1	AN
VRS1	RH-VZA032DRE0	Varistor (10G471K)	1	AE
ZD2	VHEHZ161///-1	Zener diode (HZ16-1)	1	AA
ZD3	VHEHZ5C2///-1	Zener diode (HZ5C-2)	1	AA
ZD4	VHEHZ4A2///-1	Zener diode (HZ4A2)	1	AA
3- 2	DPNLCB575WRK0	Control panel frame with key unit	1	BD
3- 2-1	FUNTKA958WRE0	Key unit	1	AW
3- 2-2	JBTN-B110WRF0	Open button	1	AF
3- 2-3	MSPRCA050WRE0	Open button spring	1	AB
3- 2-4	GCOVAA274WRP0	C/P decoration	1	AR
3- 2-5	GMADIA110WRF0	Display window	1	AF
3- 3	LANGTA340WRW0	Control panel back plate	1	AK
3- 4	MLEVFA057WRW0	Open lever	1	AE
3- 5	NSFTTA042WRE0	Open shaft	1	AE
3- 6	XEPSD30P10XS0	Screw ; control unit mtg.	3	AA
3- 7	XCPSD40P12000	Screw ; control panel back plate mtg.	3	AA
3- 8	XOTSD40P12RV0	Screw ; 4mm x 12mm	1	AA

OVEN PARTS

△ 4- 1	*****	Oven cavity assembly (Not a replaceable part)	1	--
4- 2	FROLPA072WRK0	Turntable support	1	AL
4- 3	NTNT-A019WRH0	Turntable tray	1	AT
4- 4	FBRGMA002WRE0	Bearing ass'y	1	AQ
4- 5	PREFHA028WRW0	Thermal protection plate (left)	1	AR
4- 6	LANGTA196WRW0	Bearing mounting plate	1	AD
4- 7	LBNDK0054WRE0	Heater element holder	2	AB
4- 8	LFIX-A013WRW0	Bearing holder plate	1	AB
4- 9	NFANMA019WRW0	Convection fan	1	AE
4-10	NPLYBA020WRF0	Pulley (F)	1	AC
4-11	FDUC-A279WRK0	Heater duct assembly	1	AT
4-12	PFPF-A138WRE0	Thermal protection sheet (left)	1	AK
4-13	LANGKA723WRP0	Glass mounting plate	1	AE
4-14	PCUSUA167WRP0	Cushion	2	AF
4-15	PCUSUA424WRP0	Cushion	1	AG
4-16	FDUC-A322WRW0	Steam duct assembly	1	BB
4-17	MCAMPA030WRF0	Damper cam	1	AC
4-18	NSFTTA114WRE0	Damper shaft	1	AB
4-19	FFTA-A034WRK0	Damper door ass'y	1	AM
4-20	PDUC-A269WRW0	Damper duct	1	AK
4-21	PCUSGA398WRP0	Cushion	1	AC

REF. NO.	PART NO.	DESCRIPTION	Q'TY	CODE
4-22	NCPL-A021WRF0	Turntable coupling	1	AE
4-23	PCOVPA301WRE0	Waveguide cover	1	AE
4-24	PCUSUA197WRP0	Cushion	2	AD
4-25	PGLSPA455WRE0	Light glass	1	AD
4-26	PFPF-A139WRE0	Thermal protection sheet (Right)	1	AF
4-27	PREFHA053WRW0	Thermal protection plate (Right)	1	AP
4-28	PSKR-A153WRW0	Air guide (Bottom)	1	AK
4-29	PSKR-A323WRW0	Air guide (Right)	1	AF
4-30	LANGQA407WRW0	Convection motor mounting plate	1	AG
4-31	NPLYBA021WRF0	Pulley (M)	1	AC
4-32	NFANJA020WRE0	Fan blade	1	AE
4-33	PDUC-A270WRF0	Cooling fan duct	1	AL
4-34	LANGFA089WRW0	Chassis support	1	AE
4-35	MHNG-A165WRM0	Oven hinge (Upper)	1	AE
4-36	NBLTKA005WRE0	Convection fan belt	1	AF
4-37	PFPF-A064WRE0	Thermal protection sheet	1	AF
4-38	PCUSUA196WRP0	Cushion	2	AD
4-39	PCUSUA425WRP0	Damper duct cushion	1	AG
4-40	PCUSGA353WRP0	Cushion	1	AH
4-41	PSKR-A171WRW0	Magnetron air guide	1	AE

DOOR PARTS

5	CDORFA844WRK0	Door panel assembly complete	1	BS
5- 1	DDORFA820WRY0	Door panel	1	BD
5- 2	PGLSPA534WRE0	Door glass	1	AZ
5- 3	GCOVHA155WRF0	Choke cover	1	AP
5- 4	GWAKPA665WRF0	Door frame	1	AX
5- 5	GCOVAA273WRP0	Door decoration	1	BA
5- 6	LANGKA851WRT0	Latch angle	1	AF
5- 7	LSTPPA169WRF0	Latch head	1	AH
5- 8	MSPRTA192WRE0	Latch head spring	1	AC
5- 9	LANGKA918WRW0	Thermal plate U	1	AH
5-10	LANGKA919WRW0	Thermal plate R	1	AF
5-11	XCPD40P08000	Screw; 4mm x 8mm	6	AA
5-12	XEBSD30P08000	Screw; 3mm x 8mm	12	AA
5-13	PCUSGA537WRPZ	Cushion	1	AD

MISCELLANEOUS

6- 1	FAMI-A088WRM0	Low rack (Broiling trivet)	1	AW
6- 2	FAMI-A087WRM0	High rack (Baking rack)	1	AW
6- 3	TCADCA522WRR0	Cook book	1	BA
6- 4	FW-VZB342WRE0	Thermistor harness	1	AN
6- 5	FW-VZB668WRE0	Main wire harness	1	AZ
6- 6	QW-QZA198WRE0	High voltage wire B	1	AN
6- 7	QW-VZA108WRE0	Grounding wire (Cooling fan motor)	1	AF
6- 8	TCAUAA240WRR0	Screw caution label	1	AC
6- 9	TCAUAA200WRR0	Monitor caution label	1	AB
6-10	TCAUAA209WRR0	DHHS caution label	1	AD
6-11	TINSEA815WRR0	Operation manual	1	AG

SCREWS NUTS AND WASHERS

7- 1	XOTWW40P10000	Screw; 4mm x 10mm	14	AA
7- 2	XOTSE40P12000	Screw; 4mm x 12mm	4	AA
7- 3	XCTWW40P08000	Screw; 4mm x 8mm	2	AA
7- 4	XHTSD40P08RV0	Screw; 4mm x 8mm	1	AA
7- 5	LX-CZ0052WRE0	Special screw	2	AA
7- 6	XWVSD60-07000	Washer; 6mm x 0.7 mm	1	AA
7- 7	LX-WZA004WRE0	Washer	1	AA
7- 8	LX-CZA074WRE0	Special screw	6	AC
7- 9	XBPSD30P14K00	Screw; 3mm x 14mm	1	AA
7-10	XBPSD40P25000	Screw; 4mm x 25mm	2	AA
7-11	XBTWW40P06000	Screw; 4mm x 6mm	7	AA
7-12	XCTSD40P08000	Screw; 4mm x 8mm	7	AA
7-13	XCPD40P10000	Screw; 4mm x 10mm	1	AA
7-14	XBPSD40P06KS0	Screw; 4mm x 6mm	2	AA
7-15	LX-WZA022WRE0	Washer	1	AB
7-16	XCPD40P08000	Screw; 4mm x 8mm	6	AA
7-17	XCPD30P06000	Screw; 3mm x 6mm	3	AA
7-18	LX-CZA070WRE0	Special screw (Torx tamper proof screw)	2	AC
7-19	XHPSD40P08K00	Screw; 4mm x 8mm	2	AC
7-20	XHTSD40R12RV0	Screw; 4mm x 12mm	1	AA
7-21	XCBWW30P06000	Screw; 3mm x 6mm	4	AA
7-22	XFPSD40P08000	Screw; 4mm x 8mm	6	AA
7-23	XFPSD60P14JS0	Screw; 6mm x 14mm	2	AB

REF. NO.	PART NO.	DESCRIPTION	Q'TY	CODE
7-24	XOTSD40P12000	Screw; 4mm x 12mm	16	AA
7-25	XHPSD30P08000	Screw; 3mm x 8mm	2	AA
7-26	XNESD40-32000	Nut; 4mm x 3.2mm	2	AA
7-27	XNEUW40-32000	Nut; 4mm x 3.2mm	1	AA
7-28	XWSUW40-10000	Washer; 4mm x 1mm	1	AA
7-29	XOTSD40P12RV0	Screw; 4mm x 12mm	5	AA

HOW TO ORDER REPLACEMENT PARTS

To have your order filled promptly and correctly, please furnish the following information.

1. MODEL NUMBER
2. REF. NO.
3. PART NO.
4. DESCRIPTION

Order Parts from the authorized SHARP parts Distributor for your area.

Defective parts required return should be returned as indicated in the Service Policy.

PACKING AND ACCESSORIES

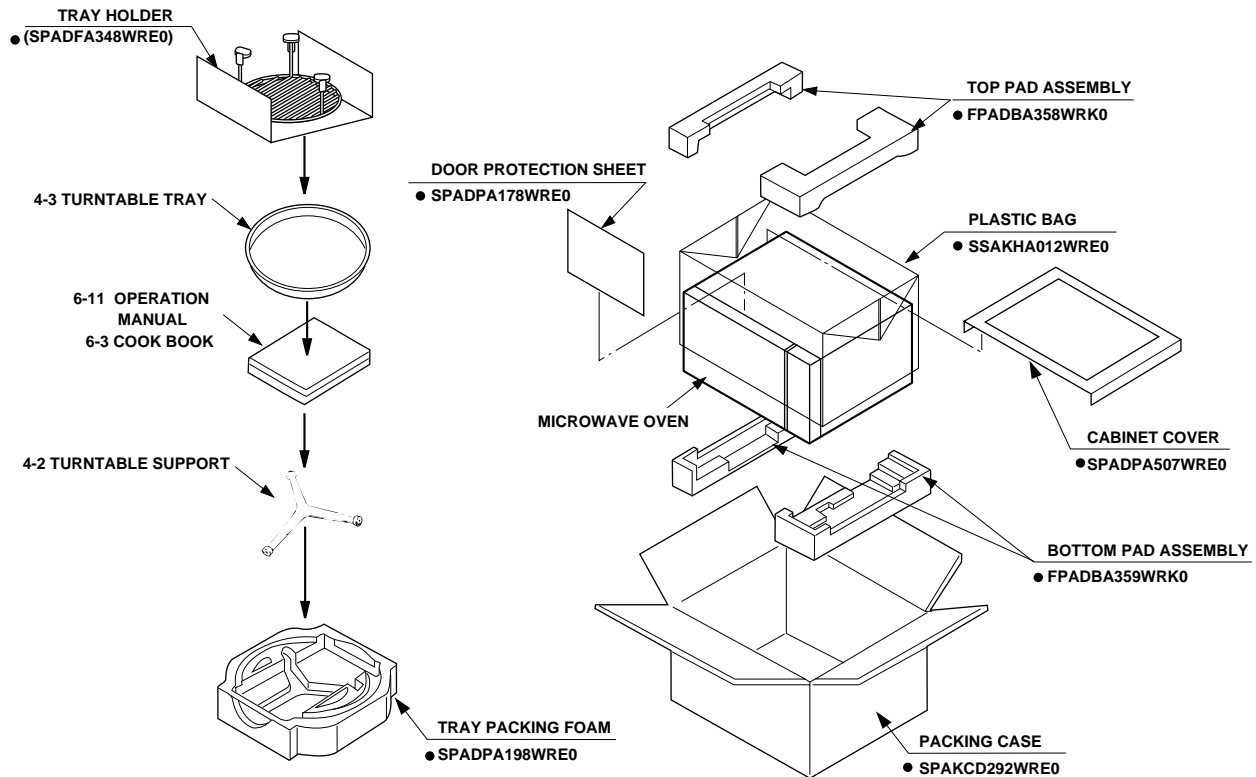

• Not replaceable items.

OVEN AND CABINET PARTS

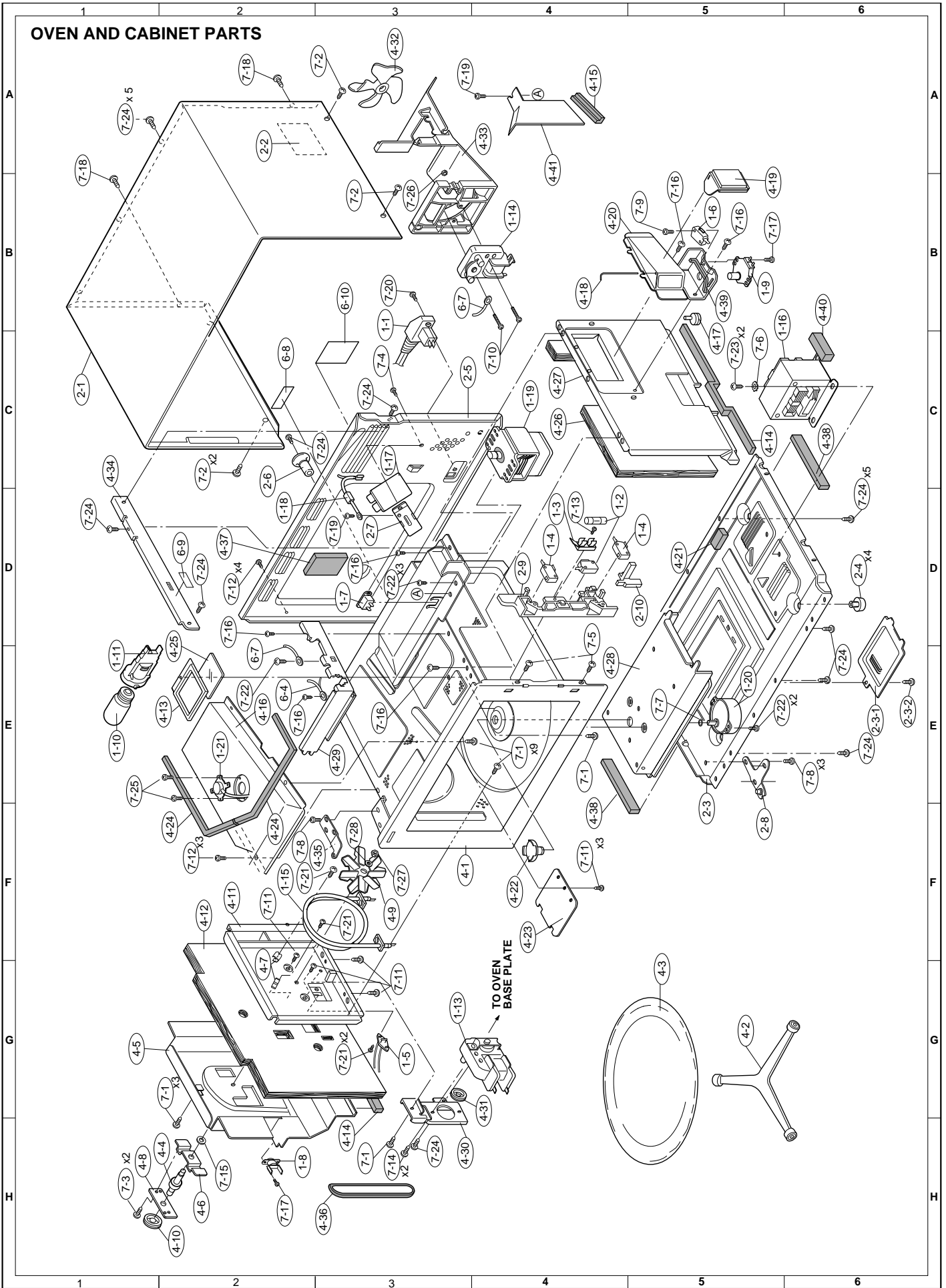

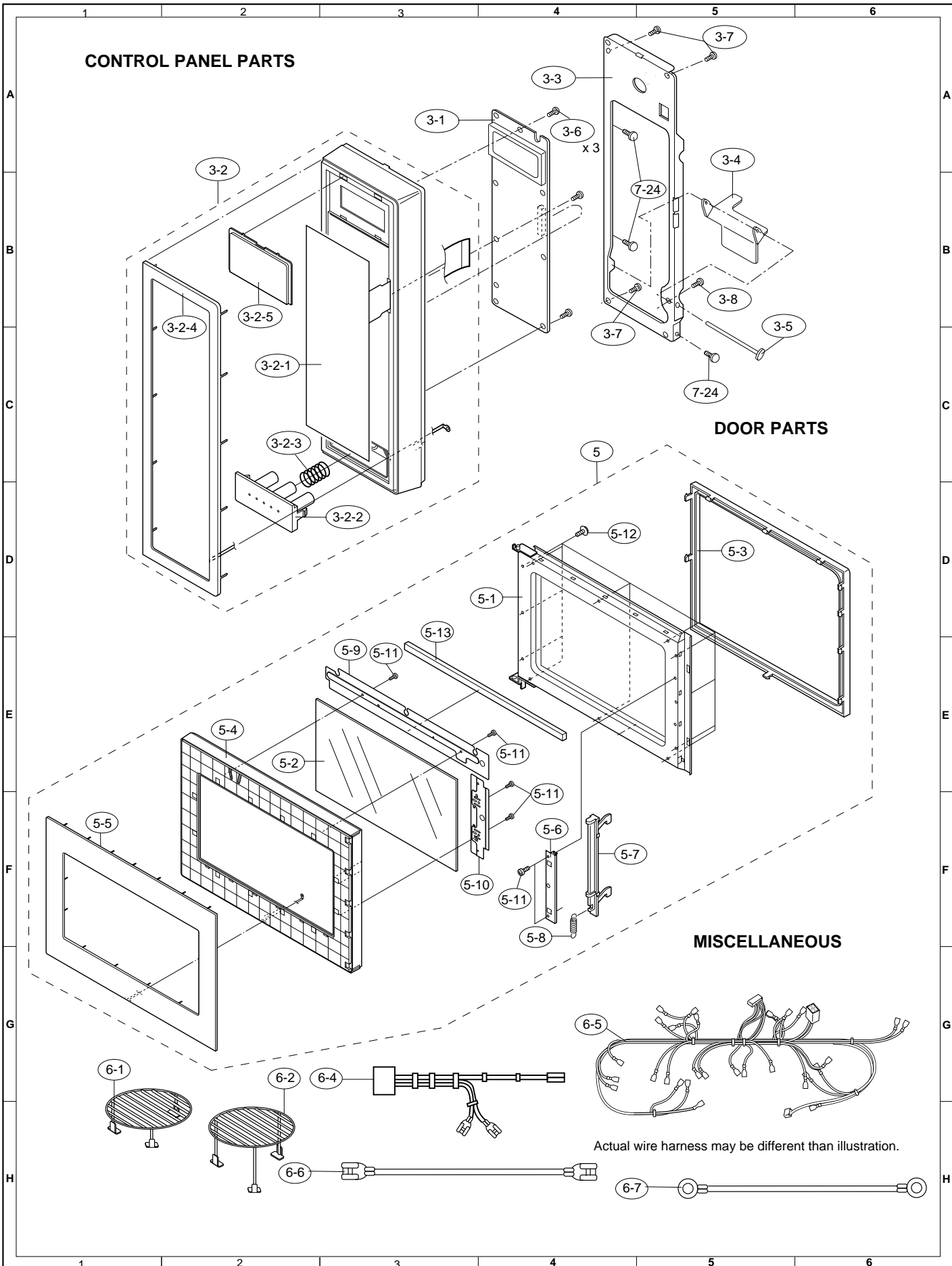

SHARP

COPYRIGHT © 1999 BY SHARP CORPORATION

ALL RIGHTS RESERVED.

No part of this publication may be reproduced, stored in retrieval systems, or transmitted in any form or by any means, electronic, mechanical, photocopying, recording, or otherwise, without prior written permission of the publisher.