

SHARP

SERVICE MANUAL

S17M398SMD0AH

MICROWAVE DRAWER MODEL

SMD2470AH



In the interest of user-safety the unit should be restored to its original condition and only parts identical to those specified should be used.

WARNING TO SERVICE PERSONNEL:

This service manual is intended for use by persons having electrical and mechanical training and a level of knowledge of these subjects generally considered acceptable in the appliance repair trade. SHARP ELECTRONICS CORPORATION cannot be responsible, nor assume any liability, for injury or damage of any kind arising from the use of this manual.

TABLE OF CONTENTS

	Page
PRECAUTIONS TO BE OBSERVED BEFORE AND DURING SERVICING TO AVOID POSSIBLE EXPOSURE TO EXCESSIVE MICROWAVE ENERGY	INSIDE FRONT COVER
BEFORE SERVICING	INSIDE FRONT COVER
WARNING TO SERVICE PERSONNEL	3
MICROWAVE MEASUREMENT PROCEDURE	4
FOREWORD AND WARNING	5
PRODUCT SPECIFICATIONS	6
SCHEMATICS	10
TROUBLE SHOOTING GUIDE	11
TEST PROCEDURES	13
MICROWAVE DRAWER DISASSEMBLY	25
WIRING DIAGRAMS	32
PARTS LIST	33
PACKING AND ACCESSORIES	39

SHARP ELECTRONICS CORPORATION

This document has been published to be used for after sales service only. The contents are subject to change without notice.

PRECAUTIONS TO BE OBSERVED BEFORE AND DURING SERVICING TO AVOID POSSIBLE EXPOSURE TO EXCESSIVE MICROWAVE ENERGY

- (a) Do not operate or allow the oven to be operated with the door open.
- (b) Make the following safety checks on all ovens to be serviced before activating the magnetron or other microwave source, and make repairs as necessary: (1) interlock operation, (2) proper door closing, (3) seal and sealing surfaces (arcing, wear, and other damage), (4) damage to or loosening of hinges and latches, (5) evidence of dropping or abuse.
- (c) Before turning on microwave power for any service test or inspection within the microwave generating compartments, check the magnetron, wave guide or transmission line, and cavity for proper alignment, integrity, and connections.
- (d) Any defective or misadjusted components in the interlock, monitor, door seal, and microwave generation and transmission systems shall be repaired, replaced, or adjusted by procedures described in this manual before the oven is released to the owner.
- (e) A microwave leakage check to verify compliance with the Federal Performance Standard should be performed on each oven prior to release to the owner.

BEFORE SERVICING

Before servicing an operative unit, perform a microwave emission check as per the Microwave Measurement Procedure outlined in this service manual.

If microwave emissions level is in excess of the specified limit, contact SHARP ELECTRONICS CORPORATION immediately @ 1-800-237-4277.

TO ACCESS INTERNET: <http://www.sharpusa.com/Support.aspx>

If the unit operates with the door open, service person should 1) tell the user not to operate the oven and 2) contact SHARP ELECTRONICS CORPORATION and Food and Drug Administration's Center for Devices and Radiological Health immediately.

Service personnel should inform SHARP ELECTRONICS CORPORATION of any certified unit found with emissions in excess of $4\text{mW}/\text{cm}^2$. The owner of the unit should be instructed not to use the unit until the oven has been brought into compliance.

WARNING TO SERVICE PERSONNEL

Microwave Oven units contain circuitry capable of producing very high voltage and current, contact with following parts may result in a severe, possibly fatal, electrical shock.

(Example)

High Voltage Capacitor, High Voltage Power Transformer, Magnetron, High Voltage Rectifier Assembly, High Voltage Harness, Heating Elements, etc..

Read the Service Manual carefully and follow all instructions.

Before Servicing

1. Disconnect the power supply cord , and then remove cabinet.
2. Open the drawer and keep it open.
3. Discharge high voltage capacitor.

**WARNING: RISK OF ELECTRIC SHOCK.
DISCHARGE THE HIGH-VOLTAGE
CAPACITOR BEFORE SERVICING.**

The high-voltage capacitor remains charged about 60 seconds after the oven has been switched off. Wait for 60 seconds and then short-circuit the connection of the high-voltage capacitor (that is the connecting lead of the high-voltage rectifier) against the chassis with the use of an insulated screwdriver.

Whenever troubleshooting is performed the power supply must be disconnected. It may, in some cases, be necessary to connect the power supply after the outer case has been removed, in this event:

1. Disconnect the power supply cord, and then remove necessary covers.
2. Open the drawer and keep it open.
3. Discharge high voltage capacitor.
4. Disconnect the leads to the primary of the power transformer.
5. Ensure that the leads remain isolated from other components and oven chassis by using insulation tape.
6. After that procedure, reconnect the power supply cord.

When the testing is completed,

1. Disconnect the power supply cord, and then remove covers.
2. Open the drawer and keep it open.
3. Discharge high voltage capacitor.
4. Reconnect the leads to the primary of the power transformer.
5. Reinstall the covers.
6. Reconnect the power supply cord.
7. Run the unit and check all functions.

After repairing

1. Reconnect all leads removed from components during testing.
2. Reinstall the covers.
3. Reconnect the power supply cord.
4. Run the oven and check all functions.

Microwave ovens should not be operated empty. To test for the presence of microwave energy within a cavity, place a cup of cold water on the oven tray, close the drawer and set the power to HIGH and set the microwave timer for two (2) minutes. When the two minutes has elapsed (timer at zero) carefully check that the water is now hot. If the water remains cold carry out **Before Servicing** procedure and re-examine the connections to the component being tested.

When all service work is completed and the oven is fully assembled, the microwave power output should be checked and a microwave leakage test should be carried out.

MICROWAVE MEASUREMENT PROCEDURE

A. Requirements:

- 1) Microwave leakage limit (Power density limit): The power density of microwave radiation emitted by a microwave oven should not exceed $1\text{mW}/\text{cm}^2$ at any point 5cm or more from the external surface of the oven, measured prior to acquisition by a purchaser, and thereafter (through the useful life of the oven), $5\text{mW}/\text{cm}^2$ at any point 5cm or more from the external surface of the oven.
- 2) Safety interlock switches:
Primary interlock relay switch shall prevent microwave radiation emission in excess of the requirement as above mentioned. Secondary interlock relay and door sensing switch shall prevent microwave radiation emission in excess of $5\text{mW}/\text{cm}^2$ at any point 5cm or more from the external surface of the oven.

B. Preparation for testing:

Before beginning the actual measurement of leakage, proceed as follows:

- 1) Make sure that the actual instrument is operating normally as specified in its instruction booklet.

Important:

Survey instruments that comply with the requirement for instrumentation as prescribed by the performance standard for microwave ovens, 21 CFR 1030.10(c)(3)(i), must be used for testing.

- 2) Place the load of 275 ± 15 ml (9.8 oz) of tap water initially at $20\pm 5^\circ\text{C}$ (68°F) in the center of the oven cavity.
The water container shall be a low form of 600 ml (20 oz) beaker with an inside diameter of approx. 8.5 cm (3-1/2 in.) and made of an electrically nonconductive material such as glass or plastic.
The placing of this standard load in the oven is important not only to protect the oven, but also to insure that any leakage is measured accurately.
- 3) Set the cooking control on Full Power Cooking Mode.
- 4) Close the drawer and select a cook cycle of several minutes. If the water begins to boil before the survey is completed, replace it with 275 ml of cool water.

C. Leakage test:

Closed-drawer leakage test (microwave measurement):

- 1) Grasp the probe of the survey instrument and hold it perpendicular to the gap between the drawer and the body of the oven.
- 2) Move the probe slowly, not faster than 1 in./sec. (2.5 cm/sec.) along the gap, watching for the maximum indication on the meter.
- 3) Check for leakage at the drawer screen, sheet metal seams and other accessible positions where the continuity of the metal has been breached (eg., around the switches, indicator, and vents).
While testing for leakage around the drawer, pull the drawer away from the front of the oven as far as is permitted by the closed latch assembly.
- 4) Measure carefully at the point of highest leakage and make sure that the highest leakage is no greater than $4\text{mW}/\text{cm}^2$, and that the primary interlock switch/secondary interlock relay does turn the oven OFF before any door movement.

NOTE: After servicing, record data on service invoice and microwave leakage report.

SERVICE MANUAL

SHARP

MICROWAVE DRAWER

SMD2470AH

FOREWORD

This Manual has been prepared to provide Sharp Electronics Corp. Service Personnel and Service Information for the MICROWAVE DRAWER.

It is recommended that service personnel carefully study the entire text of this manual so that they will be qualified to render satisfactory customer service.

Check the interlock switches and the door seal carefully. Special attention should be given to avoid electrical shock and microwave radiation hazard.

WARNING

Never operate the oven until the following points are ensured.

- (A) The door is tightly closed.
- (B) The door brackets and hinges are not defective.
- (C) The door packing is not damaged.
- (D) The door is not deformed or warped.
- (E) There is not any other visible damage with the oven.

Servicing and repair work must be carried out only by trained service personnel.

DANGER

Certain initial parts are intentionally not grounded and present a risk of electrical shock only during servicing. Service personnel - Do not contact the following parts while the appliance is energized;

**High Voltage Capacitor, Power Transformer, Magnetron, High Voltage Rectifier Assembly, High Voltage Harness;
If provided, Vent Hood, Fan assembly, Cooling Fan Motor.**

All the parts marked “*” on parts list are used at voltages more than 250V.

Removal of the outer wrap gives access to voltage above 250V.

All the parts marked “Δ” on parts list may cause undue microwave exposure, by themselves, or when they are damaged, loosened or removed.

PRODUCT DESCRIPTION

SCHEMATICS

TEST PROCEDURE

MICROWAVE DRAWER
DISSASSEMBLY AND
ADJUSTMENT PROCEDURE

WIRING DIAGRAM

PARTS LIST

SHARP ELECTRONICS CORPORATION

100 PARAGON DRIVE SUITE 100,
MONTVALE NJ 07645

MICROWAVE DRAWER SPECIFICATION

ITEM	DESCRIPTION
Power Requirements	120 Volts 14.5 Amperes, 1000 watts 60 Hz Single phase, 3 wire grounded Standby power: 1 Watt
Power Output	1000 watts (IEC TEST PROCEDURE) Operating frequency of 2450MHz
Cooking Cavity Dimensions 1.2 Cubic Feet	Width 17-11/32 Height 7-7/8" Depth 16-1/2"
Outside Dimensions	Width 23-7/8" Height 15-3/4" Depth 23-1/16"
Packing Case Dimensions (Packed unit)	Width 27-11/16" Height 21-1/2" Depth 29-1/16" 86 Lbs
Control Complement	Touch Control System Clock (1:00 - 12:59) Timer (0 - 99 min. 99 seconds) Microwave Power for Variable Cooking Repetition Rate; P-HI Full power throughout the cooking time P-90 approx. 90% of Full Power P-80 approx. 80% of Full Power P-70 approx. 70% of Full Power P-60 approx. 60% of Full Power P-50 approx. 50% of Full Power P-40 approx. 40% of Full Power P-30 approx. 30% of Full Power P-20 approx. 20% of Full Power P-10 approx. 10% of Full Power P-0 No power throughout the cooking time SENSOR: Popcorn, Reheat, Potatoes, Vegetables, Cook SETTINGS: Beverage, Defrost, Melt/Soften, Keep Warm, Help/Settings, Open/Close, Start/+30 sec, Stop/Clear, Power Level, Timer/Clock, Number Pad
Oven Cavity Light	Yes
Safety Standard	UL Listed FCC Authorized DHHS Rules, CFR, Title 21, Chapter 1, Subchapter J

GENERAL INFORMATION

GROUNDING INSTRUCTIONS

This oven is equipped with a three prong grounding plug. It must be plugged into a wall receptacle that is properly installed and grounded in accordance with the National Electrical Code and local codes and ordinances.

In the event of an electrical short circuit, grounding reduces the risk of electric shock by providing an escape wire for the electric current.

WARNING: Improper use of the grounding plug can result in a risk of electric shock.

Electrical Requirements

The electrical requirements are a 120 volt 60 Hz, AC only, 15 or 20 amp. fused electrical supply. It is recommended that a separate circuit serving only this appliance be provided. When installing this appliance, observe all applicable codes and ordinances.

Where a two-pronged wall-receptacle is encountered, it is the personal responsibility and obligation of the customer to contact a qualified electrician and have it replaced with a properly grounded three-pronged wall receptacle or have a grounding adapter properly grounded and polarized. If an extension cord must be used, it should be a 3-wire, 15 amp. or higher rated cord. Do not drape over a counter top or table where it can be pulled on by children or tripped over accidentally.

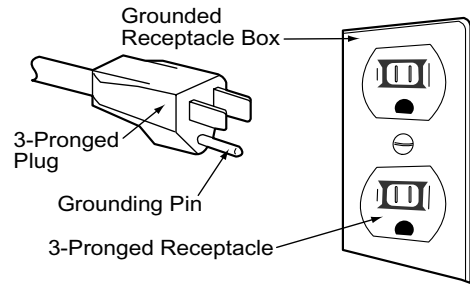

CAUTION: DO NOT UNDER ANY CIRCUMSTANCES CUT OR REMOVE THE ROUND GROUNDING PRONG FROM THIS PLUG. ALSO, "DO NOT USE AN EXTENSION CORD".

OVEN DIAGRAM

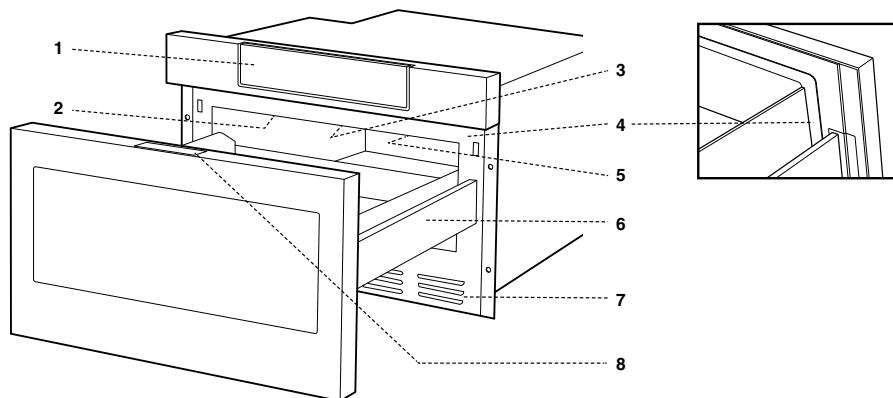

- 1 Hidden control panel & key sheet
- 2 Waveguide cover DO NOT REMOVE
- 3 Name plate: open the Microwave Drawer fully. The label is beyond the back wall of the microwave cavity facing up from the flat surface.
- 4 Drawer sealing surfaces
- 5 Drawer light
- 6 Microwave Drawer guides
- 7 Vent
- 8 Menu label
- 9 Keysheet

KEY SHEET

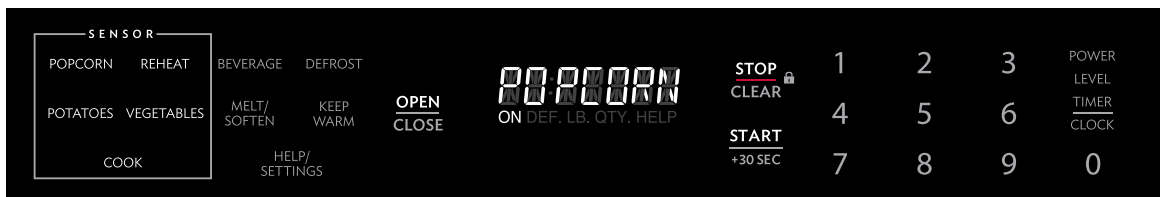

NOTE:

The directed features are disabled after one minute when the oven is not in use. These features are automatically enabled when the door is opened and closed or the STOP/ CLEAR pad is pressed.

OPERATION

DESCRIPTION OF OPERATING SEQUENCE

The following is a description of component functions during oven operation.

OFF CONDITION

Closing the drawer activates the door sensing switch and secondary interlock switch. (In this condition, the monitor switch contacts are opened.)

When oven is plugged in, 120 volts A.C. is supplied to the control unit. (Page 10).

1. The display will show flashing "Enjoy Your Drawer Touch Clear and Touch Clock".

To set any program or set the clock, you must first touch the STOP/CLEAR pad. The display will clear, and " : " will appear.

COOKING CONDITION

Program desired cooking time by touching the NUMBER pads. Program the power level by touching the POWER LEVEL pad and then a Number pad.

When the START pad is touched, the following operations occur:

1. The contacts of relays are closed and components connected to the relays are turned on as follows. (For details, refer to Page 10)

RELAY	CONNECTED COMPONENTS
RY-1	Oven lamp/stir fan motor/fan motor
RY-2	Power transformer
RY-3	Stirrer motor
RY-4	Fan motor

2. 120 volts A.C. is supplied to the primary winding of the power transformer and is converted to about 3.3 volts A.C. output on the filament winding, and approximately 2370 volts A.C. on the high voltage winding.
3. The filament winding voltage heats the magnetron filament and the H.V. winding voltage is sent to a voltage doubler circuit.
4. The microwave energy produced by the magnetron is channelled through the waveguide into the cavity feed-box, and then into the cavity where the food is placed to be cooked.
5. Upon completion of the cooking time, the power transformer, oven lamp, etc. are turned off, and the generation of microwave energy is stopped. The oven will revert to the OFF condition.
6. When the drawer is opened during a cook cycle, the monitor switch, door sensing switch, secondary interlock switch, relay (RY1) and primary interlock relay are activated with the following results. The circuits to the stir fan motor, the cooling fan motor, and the high voltage components are de-energized, the oven lamp remains on, and the digital read-out displays the time still remaining in the cook cycle when the door was opened.

7. The monitor switch electrically monitors the operation of the secondary interlock switch and secondary interlock relay and is mechanically associated with the drawer so that it will function in the following sequence.
8. When the drawer opens from the closed position, the primary interlock relay (RY2) and secondary interlock switch open their contacts. And contacts of the relay (RY1) remains closed. Then the monitor switch contacts close.
9. When the drawer is closed from the open position, the monitor switch contacts open first. Then the contacts of the secondary interlock switch and door sensing switch close. And contacts of the relay (RY1) open.

If the secondary interlock switch and primary interlock relay (RY2) fail with the contacts closed when the drawer is opened, the closing of the monitor switch contacts will form a short circuit through the fuse, secondary interlock switch, relay (RY1) and secondary interlock relay (RY2), causing the fuse to blow.

POWER LEVEL P-0 TO P-90 COOKING

When Variable Cooking Power is programmed, the 120 volts A.C. is supplied to the power transformer intermittently through the contacts of relay (RY-2) which is operated by the control unit within a 32 second time base. Microwave power operation is as follows:

VARI-MODE	ON TIME	OFF TIME
Power 10(P-HI) (100% power)	32 sec.	0 sec.
Power 9(P-90) (approx. 90% power)	30 sec.	2 sec.
Power 8(P-80) (approx. 80% power)	26 sec.	6 sec.
Power 7(P-70) (approx. 70% power)	24 sec.	8 sec.
Power 6(P-60) (approx. 60% power)	22 sec.	10 sec.
Power 5(P-50) (approx. 50% power)	18 sec.	14 sec.
Power 4(P-40) (approx. 40% power)	16 sec.	16 sec.
Power 3(P-30) (approx. 30% power)	12 sec.	20 sec.
Power 2(P-20) (approx. 20% power)	8 sec.	24 sec.
Power 1(P-10) (approx. 10% power)	6 sec.	26 sec.
Power 0(P-0) (0% power)	0 sec.	32 sec.

Note: The ON/OFF time ratio does not correspond with the percentage of microwave power, because approx. 2 seconds are needed for heating of the magnetron filament.

SENSOR COOKING CONDITION

Using the SENSOR function, food is cooked without figuring time, power level or quantity. When the oven senses enough steam from the food, it relays the information to its microprocessor which will calculate the remaining cooking time and power level needed for best results. When the food is cooked, water vapor is developed. the sensor "senses" the vapor and its resistance increase gradually. When the resistance reaches the value set according to the menu, supplementary cooking is started.

The time of supplementary cooking is determined by experiment with each food category and inputted into the LSI. An example of how sensor works: (Potatoes)



1. Potatoes at room temperature. Vapor is emitted very slowly.

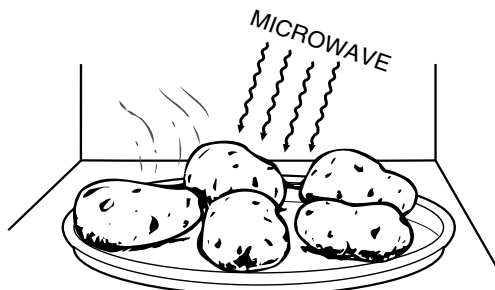

2. Heat Potatoes. Moisture and humidity is emitted very rapidly. You can smell the aroma as it cooks.

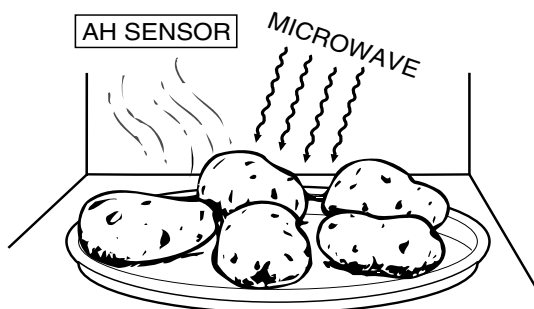

3. Sensor detects moisture and humidity and calculates cooking time and variable power.

Cooking Sequence.

1. Touch one of the SENSOR pads.

NOTE: The oven should not be operated on sensor immediately after plugging in the unit. Wait two minutes before cooking on SENSOR.

2. The coil of shut-off relay (RY-1) is energized, but the power transformer is not turned on.
3. After about 16 seconds, the cook relay (RY-2) is energized. The power transformer is turned on, microwave energy is produced and first stage is started. The 16 seconds is the cooling time required to remove any vapor from the oven cavity and sensor.

NOTE: During this first stage, do not open the drawer or touch STOP/CLEAR pad.

4. When the sensor detects the vapor emitted from the food, the display switches over to the remaining cooking time and the timer counts down to zero. At this time, the drawer may be opened to stir, turn or season food.
5. When the timer reaches zero, an audible signal sounds. The shut-off relay and cook relay are de-energized and the power transformer, oven lamp, etc. are turned off.
6. Opening the drawer or touching the STOP/CLEAR pad, the time of the day will reappear on the display and the oven will revert to an OFF condition. When the timer reaches zero, an audible signal sounds.

SCHEMATIC (OFF CONDITION)

CIRCUITS SUBJECT TO CHANGE WITHOUT NOTICE.

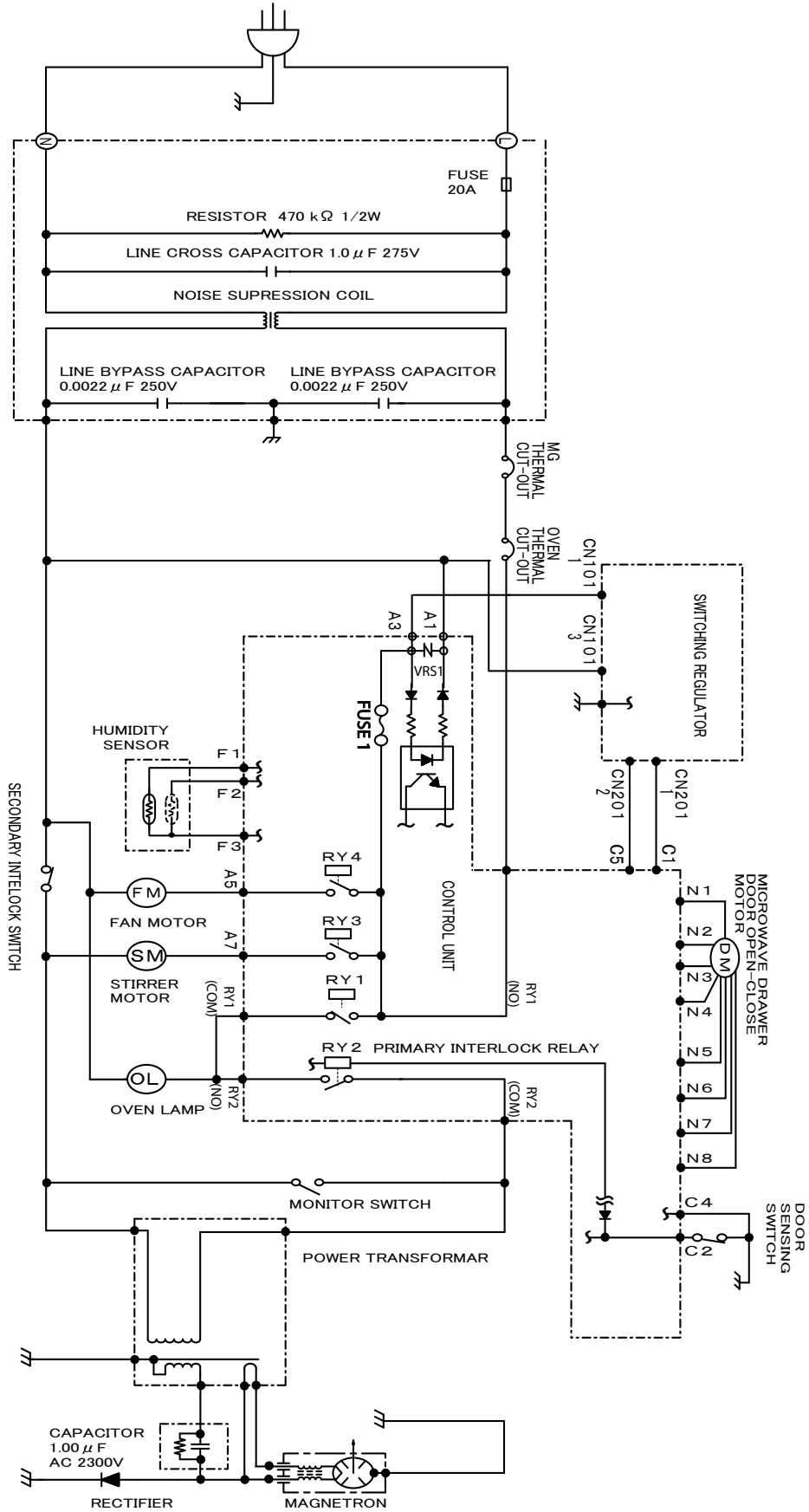

TROUBLESHOOTING GUIDE

Never touch any part in the circuit with your hand or an uninsulated tool while the power supply is connected.

When troubleshooting the microwave oven, it is helpful to follow the Sequence of Operation in performing the checks. Many of the possible causes of trouble will require that a specific test be performed. These tests are given a procedure letter (A ~ P) which will be found in the "Test Procedure "section (starting on Page 13).

IMPORTANT: If the oven becomes inoperative because of a blown monitor fuse, check the primary switch, and monitor switch, before replacing the monitor fuse. If the monitor fuse is replaced, the monitor switch must also be replaced.

IMPORTANT: Whenever troubleshooting is performed with the power supply cord disconnected. It may in, some cases, be necessary to connect the power supply cord after the outer case has been removed, in this event,

1. Disconnect the power supply cord, and then remove outer case.
2. Open the door and block it open.
3. Discharge high voltage capacitor.
4. Disconnect the leads to the primary of the power transformer.
5. Ensure that the leads remain isolated from other components and oven chassis by using insulation tape.
6. After that procedure, reconnect the power supply cord.

When the testing is completed

1. Disconnect the power supply cord, and then remove outer case.
2. Open the door and block it open.
3. Discharge high voltage capacitor.
4. Reconnect the leads to the primary of the power transformer.
5. Reinstall the outer case (cabinet).
6. Reconnect the power supply cord after the outer case is installed.
7. Run the oven and check all functions.

TROUBLESHOOTING CHART

CK = Check / RE = Replace

TEST PROCEDURE REFERENCE LETTER →		A	B	C	C	C	D	E&Q	F	G	H	H	I	I&J	K	L	M	N	O	P	RE	RE	RE	RE	CK	CK	CK	CK	CK		
POSSIBLE CAUSE AND DEFECTIVE PARTS		POWER SUPPLY	KEY UNIT	RELAY (RY1) Common (O.L.)	RELAY (RY2) MICRO	RELAY (RY3) STIRRER MTR	RELAY (RY4) FAN	DEFROST	SWITCHING POWER SUPPLY	AH SENSOR	MAGNETRON	OVEN THERMAL CUT-OUT	MAG THERMAL CUT-OUT	SECONDARY/THIRD INTERLOCK SWITCH	PRIMARY/THIRD OR STOP SWITCH	MONITOR SWITCH	MONITOR FUSE	POWER TRANSFORMER	NOISE FILTER	H.V. RECTIFIER ASSEMBLY	HIGH VOLTAGE CAPACITOR	SHORT IN POWER CORD	SHORT OR OPENED WIRING	OVEN LAMP OR SOCKET	COOLING FAN MOTOR	STIRRER MOTOR	WRONG OPERATION	LOW VOLTAGE	DIRTY OVEN CAVITY	DRAWER MOTOR	
condition	problem																														
OFF condition	Home fuse or circuit breaker blows when power cord is plugged into wall receptacle	●													●	●						●	●								
	Monitor fuse blows when power cord is plugged into wall receptacle	●							●			●	●		●	●	●						●						●		
	All letters and indicators do not appear in display when power cord is first plugged into wall outlet.	●	●																					●					●		
	Display does not operate properly when STOP/CLEAR key is touched. (Buzzer should sound and ":" or time of day should appear in display.)	●	●							●														●							
	Drawer does not open/ close	●	●							●						●												●	●	●	●
	Oven lamp does not light when door is opened.			●												●									●						
cooking condition	Oven lamp does not go out when door is closed.			●										●											●	●					
	Oven lamp lights but fan motor and stirrer motor do not operate.	●	●	●		●	●							●	●									●	●						
	Oven does not go into cook cycle when START pad is touched	●				●					●							●			●	●							●		
	Oven seems to be operating but little or no heat is produced in oven load. (Food incompletely cooked or not cooked at all at end of cook cycle.)						●																	●			●	●	●	●	
	Oven goes into a cook cycle but extremely uneven heating is produced in oven load (food).	●														●											●				
	Oven does not cook properly when programmed for Cooking Power 5 mode. (Operates properly on Cooking Power 10 (HIGH) mode.)	●																											●		
	Oven goes into DEFROST-but food is not defrosted well.	●																											●		
Sensor Cooking Condition	AH sensor does not end during sensor cooking condition. (Oven does not shut off after a cup of water is boiling by sensor cooking)									●																					
	Oven stops at 16 sec. after starting ("ERROR" is in display)																														

TEST PROCEDURES

PROCEDURE LETTER	COMPONENT TEST
A	<p><u>TOUCH CONTROL PANEL ASSEMBLY TEST</u></p> <p>The touch control panel consists of circuits including semiconductors such as LSI, ICs, etc. Therefore, unlike conventional microwave ovens, proper maintenance cannot be performed with only a voltmeter and ohmmeter.</p> <p>In this service manual, the touch control panel assembly is divided into three units, Control Unit, Keyboard Unit and Switching Power Supply, and troubleshooting by unit replacement is described according to the symptoms indicated.</p> <p>Before testing,</p> <ol style="list-style-type: none"> 1) Disconnect the power supply cord, and then disassemble as per "MICROWAVE DRAWER DISASSEMBLY" page 25. 2) Open the drawer and block it open. 3) Discharge high voltage capacitor. 4) Disconnect the leads to the primary of the power transformer. 5) Ensure that these leads remain isolated from other components and oven chassis by using insulation tape. <p>1. Keyboard Unit.</p> <p>NOTE ;</p> <ol style="list-style-type: none"> 1) Check Keyboard unit connection before replacement. 2) Reconnect all leads removed from components during testing. 3) Re-install the covers. 4) Reconnect the power supply cord after the covers are installed. 5) Run the oven and check all functions. <p>The following symptoms indicate a defective keyboard unit.</p> <ol style="list-style-type: none"> a) When touching the pads, a certain pad produces no signal at all. b) When touching a number pad, two figures or more are displayed. c) When touching the pads, sometimes a pad produces no signal. <p>If the Keyboard unit is defective.</p> <ol style="list-style-type: none"> 1) Disconnect the power supply cord, and then remove covers. 2) Open the drawer and block it open. 3) Discharge high voltage capacitor. 4) Replace the Key Unit and/or Hidden Control Panel Hinge Assembly 5) Reconnect all leads removed from components during testing. 6) Re-install the covers. 7) Reconnect the power supply cord after the covers are installed. 8) Run the oven and check all functions. <p>2. Control Unit</p> <p>The following symptoms indicate a defective control unit. Before replacing the control unit, perform the Keyboard unit test (Procedure B) to determine if control unit is faulty.</p> <p>2-1 In connection with indicators</p> <ol style="list-style-type: none"> a) At a certain digit, all or some segments do not light up. b) At a certain digit, brightness is low. c) Only one indicator does not light. d) The corresponding segments of all digits do not light up; or they continue to light up. e) Wrong figure appears. f) A certain group of indicators do not light up. g) The figure of all digits flicker. <p>2-2 Other possible problems caused by defective control unit.</p> <ol style="list-style-type: none"> a) Buzzer does not sound or continues to sound. b) Clock does not operate properly. c) Cooking is not possible. <p>3. Power Unit or Switching Power Supply</p> <ol style="list-style-type: none"> a) Fan motor, stirrer motor, oven lamp or electrical parts do not turn on or do not turn off. b) Digital display on the control unit does not show anything. <p>When testing is completed,</p> <ol style="list-style-type: none"> 1) Disconnect the power supply cord, and then disassemble as per "MICROWAVE DRAWER DISASSEMBLY" page 25. 2) Open the drawer and block it open. 3) Discharge high voltage capacitor.

TEST PROCEDURES

PROCEDURE LETTER

COMPONENT TEST

- 4) Reconnect all leads removed from components during testing.
- 5) Re-install the covers.
- 6) Reconnect the power supply cord after the covers are installed.
- 7) Run the oven and check all functions.

B

KEY UNIT TEST

1. Disconnect the power supply cord, and then remove outer case.
2. Open the drawer and block it open.
3. Discharge high voltage capacitor.
4. If the display fails to clear when the STOP/CLEAR pad is depressed, first verify the flat ribbon cable is making good contact, verify that the door sensing switch (stop switch) operates properly; that is the contacts are closed when the drawer is closed and open when the drawer is open. If the door sensing switch (stop switch) is good, disconnect the flat ribbon cable that connects the key unit to the control unit and make sure the drawer sensing switch is closed (either close the drawer or short the door sensing switch connector). Use the Key unit matrix indicated on the control panel schematic and place a jumper wire between the pins that correspond to the STOP/CLEAR pad making momentary contact. If the control unit responds by clearing with a beep the key unit is faulty and must be replaced. If the control unit does not respond, it is faulty and must be replaced. If a specific pad does not respond, the above method may be used (after clearing the control unit) to determine if the control unit or key pad is at fault.
5. Reconnect all leads removed from components during testing.
6. Re-install the outer case (cabinet).
7. Reconnect the power supply cord after the outer case is installed.
8. Run the oven and check all functions.

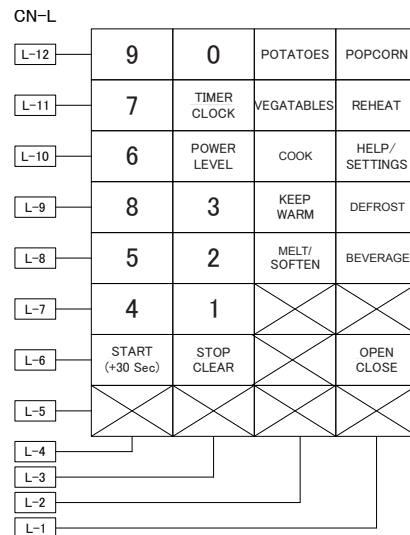

C

RELAY TEST

1. Disconnect the power supply cord, and then remove outer case.
2. Open the door and block it open.
3. Discharge high voltage capacitor.
4. Disconnect the leads to the primary of the power transformer.
5. Ensure that these leads remain isolated from other components and oven chassis by using insulation tape.
6. After that procedure, re-connect the power supply cord.
7. Remove the outer case and check voltage between pins A1~A2 which should equal 120Vac with an A.C. voltmeter , then pins C1-C5 which should be 24Vdc on the power unit with an D .C. voltmeter. The meter should indicate both the 120 volts AC and 24 volts DC , if not check the switching power supply voltages (and harness wires for break/ shorts). If it you have the voltages as stated above and there is still no operation then check oven circuit RY1, RY2, RY3 and RY4 Relay Test These relays are operated by D.C. voltage. Check voltage at the relay coil with a D.C. voltmeter during the microwave cooking operation. DC. voltage indicated Defective relay. DC. voltage not indicated Check diode which is connected to the relay coil. If diode is good, then the control unit is defective.

RELAY SYMBOL	OPERATIONAL VOLTAGE	CONNECTED COMPONENTS
RY1	Approx. 26V D.C.	Oven lamp / Common
RY2	Approx. 25V D.C.	Power transformer
RY3	Approx. 26V D.C.	Stirrer motor
RY4	Approx. 26V D.C.	Fan motor

8. Disconnect the power supply cord, and then remove outer case.
9. Open the door and block it open.
10. Discharge high voltage capacitor.
11. Reconnect all leads removed from components during testing.

PROCEDURE LETTER	COMPONENT TEST
	12.Re-install the outer case (cabinet). 13.Reconnect the power supply cord after the outer case is installed. 14.Run the oven and check all function.

D DEFROST TEST

WARNING : The oven should be fully assembled before following procedure.

- (1) Place one cup of water in the center of the tray in the oven cavity.
- (2) Close the drawer, touch the Defrost pad. Then select Steaks/Chops by touching the number pad 2. And touch the number pad 5. (Now, weight 0.5lb is set.) And then touch the start pad.
- (3) The oven is in Defrost cooking condition.
- (4) The oven will operate as follows

WEIGHT	1ST STAGE		2ND STAGE		3RD. STAGE	
	LEVEL	TIME	LEVEL	TIME	LEVEL	TIME
0.5lb	60%	20sec.	40%	20sec.	30%	45sec.

- (5) If improper operation is indicated, the control unit is probably defective and should be checked.

E PROCEDURES TO BE TAKEN WHEN THE FUSE IS OPEN

To protect the electronic circuits, this model is provided with a fuse added to the primary on the Noise Filter Unit. In addition, there is a non-replaceable fuse on the Switching Power Supply.

1. Fuse check and repairs.

- 1) Disconnect the power supply cord.
- 2) Remove the outer case cabinet.
- 3) Open the door and block it open.
- 4) Discharge high voltage capacitor.
- 5) If the Fuse is blown, replace fuse. Also do filter test per procedure N.
- 6) Make a visual inspection of the varistors on Noise Unit as well as Switching Power Supply. Check for burned damage. If the varistor on Switching Power Supply has burned damage, replace Switching Power Supply. If the varistors on Noise Unit has burned damage replace Noise Filter Unit .
- 8) Reconnect all leads removed from components during testing.
- 9) Re-install the outer case (cabinet).
- 10) Reconnect the power supply cord after the outer case is installed.
- 11) Run the oven and check all functions.

2. Follow the troubleshooting guide given below, if power is not restored after above check and repairs are finished.

- 1) Disconnect the power supply cord.
- 2) Remove the outer case cabinet.
- 3) Open the door and block it open.
- 4) Discharge high voltage capacitor.
- 5) Disconnect the leads to the primary of the power transformer.
- 6) Ensure that these leads remain isolated from other components and oven chassis by using insulation tape.
- 7) After that procedure, re-connect the power supply cord.
- 8) Follow the troubleshooting guide given below for repair.

STEPS	OCCURANCE	CAUSE OR CORRECTION
1	The rated AC voltage is NOT present across Switching Power Supply CN101 (pins 1,3)	No power to Switching Power Supply. Check for wire breaks, open thermal cutouts.
2	24Vdc is NOT present across Switching Power Supply CN201 (pins 1,2)	Switching Power Supply not operating. Re-place Switching Power Supply.
3	24Vdc is present across Power Unit CN-C (pins 1,5) /and/ The rated AC voltage is present across Power Unit CN-A (pins 1,3)	Normal power is being received by Power Unit but Power Unit is not operating. Replace Power Unit.

TEST PROCEDURES

PROCEDURE LETTER	COMPONENT TEST
	9) Disconnect the power supply cord, and then remove outer case. 10) Open the door and block it open. 11) Discharge high voltage capacitor. 12) Reconnect all leads removed from components during testing. 13) Re-install the outer case (cabinet). 14) Reconnect the power supply cord after the outer case is installed. 15) Run the oven and check all functions.

F

AH SENSOR TEST

Checking the initial sensor cooking condition

WARNING : The oven should be fully assembled before following procedure.

- (1) The oven should be plugged in at least two minutes before sensor cooking.
- (2) Room temperature should not exceed 95°F (35°C).
- (3) The unit should not be installed in any area where heat and steam are generated. The unit should not be installed, for example, next to a conventional surface unit. Refer to the "INSTALLATION INSTRUCTIONS" of the operation manual.
- (4) Exhaust vents are provided on the back of the unit for proper cooling and air flow in the cavity. To permit adequate ventilation, be sure to install so as not to block these vents. There should be some space for air circulation.
- (5) Be sure the exterior of the cooking container and the interior of the oven are dry. Wipe off any moisture with a dry cloth or paper towel.
- (6) The Sensor works with food at normal storage temperature. For example, chicken pieces would be at refrigerator temperature and canned soup at room temperature.
- (7) Avoid using aerosol sprays or cleaning solvents near the oven while using Sensor settings. The sensor will detect the vapor given off by the spray and turn off before food is properly cooked.
- (8) If the sensor has not detected the vapor of the food, ERROR will appear and the oven will shut off.

Water load cooking test

WARNING : The oven should be fully assembled before following procedure.

Make sure the oven has been plugged in at least two minutes before checking sensor cook operation. The cabinet should be installed and screws tightened.

- (1) Fill approximately 200 milliliters (7.2 oz) of tap water in a 1000 milliliter measuring cup.
- (2) Place the container on the center of tray in the oven cavity.
- (3) Close the drawer.
- (4) Touch the TIMER/CLOCK pad once, the POWER LEVEL pad twice and the START pad once. And touch the number pad 1 once and the number pad 4 once. Now, the oven is in the sensor cooking condition, and "AH20" and "ON" will appear in the display.
- (5) The oven will operate for the first 16 seconds, without generating microwave energy.

NOTE: ERROR will appear if the door is opened or STOP/CLEAR pad is touched during first stage of sensor cooking.

- (6) After approximately 16 seconds, microwave energy is produced.

If ERROR is displayed or the oven does not turn off, replace the AH sensor or check the control unit, refer to explanation below. If the oven stops after 5 minutes and no ERROR code is displayed, then the AH sensor is normal. Check other parts except the AH sensor.

TESTING METHOD FOR AH SENSOR AND/OR CONTROL UNIT

To determine if the sensor is defective, the simplest method is to replace it with a new replacement sensor.

- (1) Disconnect the power supply cord, and then disassemble as per "MICROWAVE DRAWER DISASSEMBLY" page 25.
- (2) Open the drawer and block it open.
- (3) Discharge high voltage capacitor.
- (4) Remove the AH sensor.
- (5) Install the new AH sensor.
- (6) Reconnect all leads removed from components during testing.
- (7) Re-install the covers.
- (8) Reconnect the power supply cord after the covers are installed.
- (9) Reconnect the oven to the power supply and check the sensor cook operation as follows:
 - 9-1. Fill approximately 200 milliliters (7.2 oz) of tap water in a 1000 milliliter measuring cup.

TEST PROCEDURES

**PROCEDURE
LETTER**

COMPONENT TEST

- 9-2. Place the container on the center of tray in the oven cavity.
 - 9-3. Close the drawer.
 - 9-4. Touch the TIMER/CLOCK pad once, the POWER LEVEL pad twice and the START pad once. And touch the number pad 1 once and the number pad 4 once.
 - 9-5. The control panel is in automatic Sensor operation.
 - 9-6. The oven turns off automatically, and the time for detecting moisture will be displayed.
- If new sensor does not operate properly, the problem is with the control unit, and refer to explanation below.

CHECKING CONTROL UNIT

- (1) Disconnect the power supply cord, and then disassemble as per "MICROWAVE DRAWER DISASSEMBLY" page 25.
- (2) Open the drawer and block it open.
- (3) Discharge high voltage capacitor.
- (4) Disconnect the sensor connector that is mounted to control panel.
- (5) Then connect the dummy resistor circuit (see fig.) to the sensor connector of control panel.
- (6) Disconnect the leads to the primary of the power transformer.
- (7) Ensure that these leads remain isolated from other components and oven chassis by using insulation tape.
- (8) After that procedure, re-connect the power supply cord.
- (9) Check the sensor cook operation proceed as follows:
 - 9-1. Close the door. Touch the TIMER/CLOCK pad once, the POWER LEVEL pad twice and the START pad once. And touch the number pads 1 once and the number pad 4 once.
 - 9-2. The control panel is in the sensor cooking operation.
 - 9-3. After approximately 25 seconds, push plunger of select switch for more than 3 seconds. This condition is same as judgement by AH sensor.
 - 9-4. After approximately 3 seconds, the display shows " X X . X X " which is the time for detecting moisture.

If the above is not the case, the control unit is probably defective.
If the above is proper, the AH sensor is probably defective.
- (10) Disconnect the power supply cord, and then remove covers.
- (11) Open the drawer and block it open.
- (12) Discharge high voltage capacitor.
- (13) Disconnect the dummy resistor circuit from the sensor connector of control panel.
- (14) Carry out necessary repair.
- (15) Reconnect all leads removed from components during testing and repairing.
- (16) Re-install the covers.
- (17) Reconnect the power supply cord after the outer case is installed. Run the oven and check all functions.
- (18) Carry out "Water load cooking test" again and ensure that the oven works properly.

R1, R2 : 22Ω ± 1% 1/2W
R3 : 4.3kΩ ± 5% 1/4W
R4 : 1MΩ ± 5% 1/4W

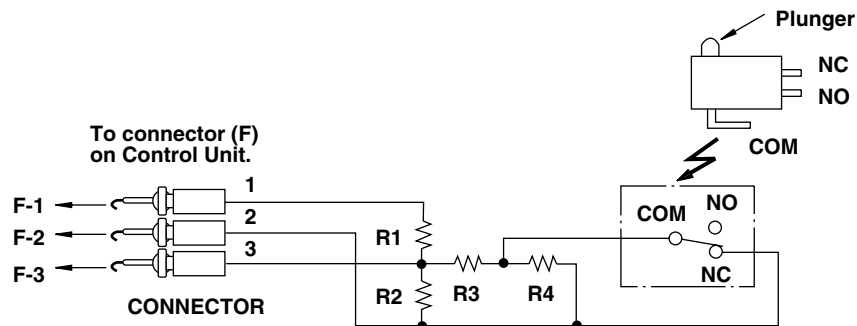

TEST PROCEDURES

**PROCEDURE
LETTER**

COMPONENT TEST

Refer to the disassembly instructions found on Page 22.

G MAGNETRON ASSEMBLY TEST

1. Disconnect the power supply cord.
2. Open the drawer and keep it open.
3. To discharge high voltage capacitor, wait for 60 seconds.
4. To test for an open filament, isolate the magnetron from the high voltage circuit. A continuity check across the magnetron filament leads should indicate less than 1 ohm.
5. To test for a shorted magnetron, connect the ohmmeter leads between the magnetron filament leads and chassis ground. This test should indicate an infinite resistance. If there is little or no resistance the magnetron is grounded and must be replaced.
6. Reconnect all leads removed from components during testing.
7. Reassemble the unit.
8. Reconnect the power supply cord.
9. Run the oven and check all functions.

MICROWAVE OUTPUT POWER

The following test procedure should be carried out with the microwave oven in a fully assembled condition.

HIGH VOLTAGES ARE PRESENT DURING THE COOK CYCLE, SO EXTREME CAUTION SHOULD BE OBSERVED.

Power output of the magnetron can be measured by performing a water temperature rise test. This test should only be used if above tests do not indicate a faulty magnetron and there is no defect in the following components or wiring: This test will require a 16 ounce (453cc) measuring cup and an accurate mercury thermometer or thermocouple type temperature tester. For accurate results, the following procedure must be followed carefully:

1. Fill the measuring cup with 16 oz. (453cc) of tap water and measure the temperature of the water with a thermometer or thermocouple temperature tester. Stir the thermometer or thermocouple through the water until the temperature stabilizes. Record the temperature of the water.
2. Place the cup of water in the oven. Operate oven at POWER 10(HIGH) selecting more than 60 seconds cook time. Allow the water to heat for 60 seconds, measuring with a stop watch, second hand of a watch or the digital read-out countdown.
3. Remove the cup from the oven and again measure the temperature, making sure to stir the thermometer or thermocouple through the water until the maximum temperature is recorded.
4. Subtract the cold water temperature from the hot water temperature. The normal result should be 28° to 54°F (16° to 30°C) rise in temperature. If the water temperatures are accurately measured and tested for the required time period the test results will indicate if the magnetron tube has low power output (low rise in water temperature) which would extend cooking time or high power output (high rise in water temperature) which would reduce cooking time. Because cooking time can be adjusted to compensate for power output, the magnetron tube assembly should be replaced only if the water temperature rise test indicates a power output well beyond the normal limits. The test is only accurate if the power supply line voltage is 120 volts and the oven cavity is clean.

H DM FUSE TEST

1. Disconnect the power supply cord.
2. Open the drawer and keep it open.
3. To discharge high voltage capacitor, wait for 60 seconds.
4. A continuity check across the DM Fuse terminals should indicate a closed circuit unless the temperature of the DM Fuse reaches approximately 293°F(145°C).
An open thermal cut-out indicates overheating of the oven, exchange the oven DM Fuse and check inside of oven cavity and for improper setting of cooking time or operation of control unit. Check for restricted air flow through the vent holes of the oven cavity, especially the cooling fan and air guide.
5. Reconnect all leads removed from components during testing.
6. Reassemble the unit.
7. Reconnect the power supply cord.
8. Run the unit and check all functions.

CAUTION: IF THE DM FUSE INDICATES AN OPEN CIRCUIT AT ROOM TEMPERATURE, REPLACE DM FUSE

TEST PROCEDURES

PROCEDURE LETTER	COMPONENT TEST
I	<p><u>SECONDARY INTERLOCK SWITCH TEST</u></p> <ol style="list-style-type: none"> 1. Disconnect the power supply cord. 2. Open the drawer and keep it open. 3. To discharge high voltage capacitor, wait for 60 seconds. 4. Isolate the switch and connect the ohmmeter to the common (COM.) and normally open (NO) terminal of the switch. The meter should indicate an open circuit with the drawer open and a closed circuit with the drawer closed. If improper operation is indicated, replace the secondary interlock switch. 5. Reconnect all leads removed from components during testing. 6. Reassemble the unit. 7. Reconnect the power supply cord. 8. Run the oven and check all functions.
J	<p><u>STOP SWITCH TEST</u></p> <p><u>STOP SWITCH</u></p> <ol style="list-style-type: none"> 1. Disconnect the power supply cord. 2. Open the drawer and keep it open. 3. To discharge high voltage capacitor, wait for 60 seconds. 4. Isolate the switch and connect the ohmmeter to the common (COM.) and normally open (NO) terminal of the switch. The meter should indicate an open circuit with the drawer open and a closed circuit with the drawer closed. If improper operation is indicated, replace the stop switch. 5. Reconnect all leads removed from components during testing. 6. Reassemble the unit. 7. Reconnect the power supply cord. 8. Run the oven and check all functions. <p>NOTE: If the stop switch contacts fail in the open position and the door is closed, the cooling fan motor, stirrer motor and oven light will be activated by RY1.</p>

K	<p><u>MONITOR SWITCH TEST</u></p> <ol style="list-style-type: none"> 1. Disconnect the power supply cord. 2. Open the drawer and keep it open. 3. To discharge high voltage capacitor, wait for 60 seconds. 4. Before performing this test, make sure that the secondary interlock switch is operating, according to the above Switch Test Procedure. Disconnect the wire lead from the monitor switch (COM) terminal. Check the monitor switch operation by using the ohmmeter as follows. When the drawer is open, the meter should indicate a closed circuit. When the monitor switch actuator is pushed by a screw driver through the lower latch hole on the front plate of the oven cavity with the drawer opened (in this condition the plunger of the monitor switch is pushed in), the meter should indicate an open circuit. If improper operation is indicated, the switch may be defective and both the monitor switch, plus fuse will need to be replaced. After testing the monitor switch, reconnect the wire lead to the monitor switch (COM) terminal and check the continuity of the monitor circuit. 5. Reconnect all leads removed from components during testing. 6. Reassemble the unit. 7. Reconnect the power supply cord. 8. Run the oven and check all functions.
----------	--

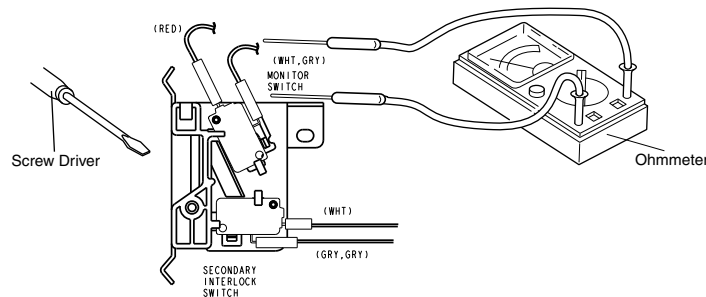

TEST PROCEDURES

PROCEDURE LETTER	COMPONENT TEST
L	<p><u>BLOWN MONITOR FUSE TEST</u></p> <ol style="list-style-type: none"> 1. Disconnect the power supply cord. 2. Open the drawer and block it open. 3. To discharge high voltage capacitor, wait for 60 seconds. 4. If the monitor fuse is blown when the drawer is opened, check the primary interlock switch, secondary interlock switch and monitor switch according to the "TEST PROCEDURE" for those switches before replacing the blown monitor fuse. <p>CAUTION: BEFORE REPLACING A BLOWN MONITOR FUSE, TEST THE SECONDARY INTERLOCK SWITCH, STOP SWITCH AND MONITOR SWITCH FOR PROPER OPERATION.</p> <p>If the monitor fuse is blown by improper switch operation, the monitor fuse and monitor switch must be replaced with "monitor fuse and monitor switch assembly" part number FFS-BA018/KIT, even if the monitor switch operates normally. The monitor fuse and monitor switch assembly is comprised of a 20 ampere fuse and switch.</p> <ol style="list-style-type: none"> 5. Reconnect all leads removed from components during testing. 6. Reassemble the unit. 7. Reconnect the power supply cord. 8. Run the oven and check all functions.
M	<p><u>POWER TRANSFORMER TEST</u></p> <ol style="list-style-type: none"> 1. Disconnect the power supply cord. 2. Open the drawer and block it open. 3. Discharge high voltage capacitor. 4. Disconnect the primary input terminals and measure the resistance of the transformer with an ohmmeter. Check for continuity of the coils with an ohmmeter. On the R x 1 scale, the resistance of the primary coil should be less than 1 ohm and the resistance of the high voltage coil should be approximately 82 ohms (+ or - 10%); the resistance of the filament coil should be less than 1 ohm. 5. Reconnect all leads removed from components during testing. 6. Reassemble the unit. 7. Reconnect the power supply cord. 8. Run the oven and check all functions. <p>CAUTION: (HIGH VOLTAGES ARE PRESENT AT THE HIGH VOLTAGE TERMINAL, SO DO NOT ATTEMPT TO MEASURE THE FILAMENT AND HIGH VOLTAGE.)</p>

TEST PROCEDURES

**PROCEDURE
LETTER**

COMPONENT TEST

N

NOISE FILTER TEST

1. Disconnect the power supply cord, and then remove outer case.
2. Open the door and block it open.
3. Discharge high voltage capacitor.
4. Disconnect the leads to the primary of the power transformer.
5. Using an ohm-meter, check between the terminals as described in the following table:

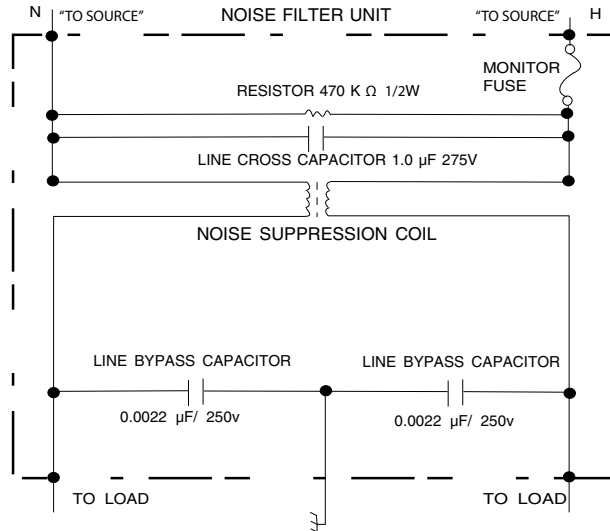

MEASURING POINT	INDICATION OF OHM-METER
Between N and H	275 - 415Ω
Between terminal N and LOAD	Short Circuit
Between terminal H and LOAD	Short Circuit
Fuse	Short Circuit

If fuse is open, replace fuse

If incorrect readings are obtained, replace the noise filter.

6. Reconnect all leads removed from components during testing.
7. Re-install the outer case (cabinet).
8. Reconnect the power supply cord after the outer case is installed.
9. Run the oven and check all functions.

O

HIGH VOLTAGE RECTIFIER TEST

1. Disconnect the power supply cord, and then remove outer case.
2. Open the door and block it open.
3. Discharge high voltage capacitor.
4. Isolate the rectifier from the circuit. Using the highest ohm scale of the meter, read the resistance across the terminals and observe, reverse the leads to the rectifier terminals and observe meter reading. If a short is indicated in both directions, or if an infinite resistance is read in both directions, the rectifier is probably defective and should be replaced.
5. Reconnect all leads removed from components during testing.
6. Reinstall the outer case (cabinet).
7. Reconnect the power supply cord after the outer case is installed.
8. Run the oven and check all functions.

NOTE: Be sure to use an ohmmeter that will supply a forward bias voltage of more than 6.3 volts.

TEST PROCEDURES

PROCEDURE LETTER	COMPONENT TEST
P	<p>HIGH VOLTAGE CAPACITOR TEST</p> <ol style="list-style-type: none">1. Disconnect the power supply cord, and then remove outer case.2. Open the door and block it open.3. Discharge high voltage capacitor.4. If the capacitor is open, no high voltage will be available to the magnetron. Disconnect input leads and check for short or open between the terminals using an ohmmeter. Checking with a high ohm scale, if the high voltage capacitor is normal, the meter will indicate continuity for a short time and should indicate an open circuit once the capacitor is charged. If the above is not the case, check the capacitor with an ohmmeter to see if it is shorted between either of the terminals and case. If it is shorted, replace the capacitor.5. Reconnect all leads removed from components during testing.6. Reinstall the outer case (cabinet).7. Reconnect the power supply cord after the outer case is installed.8. Run the oven and check all functions.
Q	<p>SWITCHING POWER SUPPLY</p> <ol style="list-style-type: none">1. Check AC power into CN101, if none check Main Harness.2. Check DC power across CN201 (DC24V), if none replace Switching Power Supply Unit3. Check for DC getting from Switching Power Supply Unit to PSU/ CPU, if none check Main Harness.

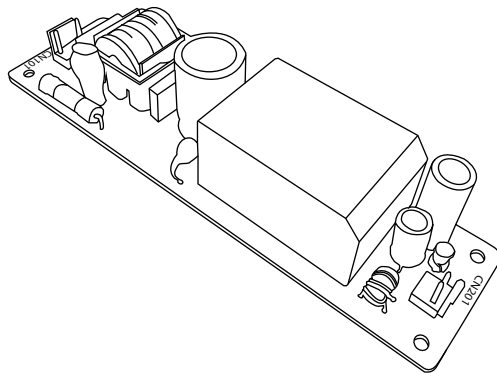

HUMIDITY SENSOR CIRCUIT

(1) Structure of Humidity Sensor

The humidity sensor includes two thermistors as shown in the illustration. One thermistor is housed in the closed vessel filled with dry air while another in the open vessel. Each sensor is provided with the protective cover made of metal mesh to be protected from the external airflow.

ventilation opening for sensing

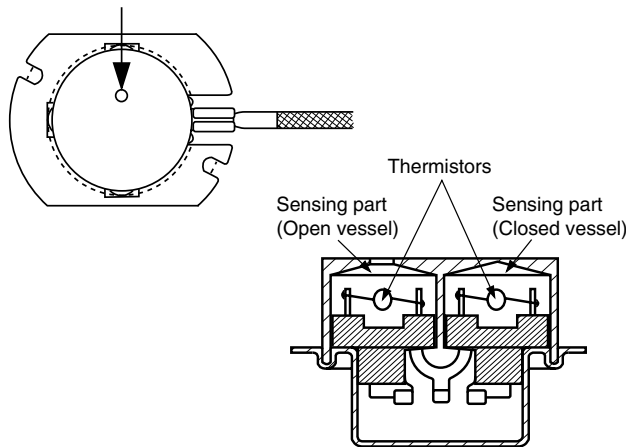

(2) Operational Principle of Humidity Sensor

The figure below shows the basic structure of an absolute humidity sensor. A bridge circuit is formed by two thermistors and two resistors (R1 and R2). The output of the bridge circuit is to be amplified by the operational amplifier. Each thermistor is supplied with a current to keep it heated at about 150°C (302°F), the resultant heat is dissipated in the air and if the two thermistors are placed in different humidity conditions they show different degrees of heat conductivity leading to a potential difference between them causing an output voltage from the bridge circuit, the intensity of which is increased as the absolute humidity of the air increases. Since the output is varied every minute, it is amplified by the operational amplifier.

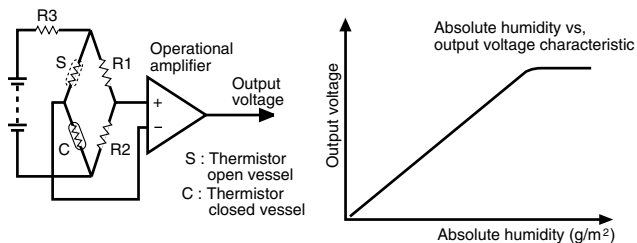

(3) Detector Circuit of Humidity Sensor Circuit

This detector circuit is used to detect the output voltage of the absolute humidity circuit to allow the LSI to control sensor cooking of the unit. When the unit is set in the sensor cooking mode, 16 seconds clearing cycle occurs than the detector circuit starts to function and the LSI observes the initial voltage available at its AN6 terminal.

With this voltage given, the switches SW1 to SW5 in the LSI are turned on in such a way as to change the resistance values in parallel with R45 ~ R49. Changing

the resistance values results in that there is the same potential at both F-3 terminal of the absolute humidity sensor and AN6 terminal of the LSI. The voltage of AN7 terminal will indicate about +2.5V. This initial balancing is set up about 16 seconds after the unit is put in the Sensor Cooking mode. As the sensor cooking proceeds, the food is heated to generate moisture by which the resistance balance of the bridge circuit is deviated to increase the voltage available at AN6 terminal of the LSI.

Then the LSI observes that voltage at AN7 terminal and compares it with its initial value, and when the comparison rate reaches the preset value (fixed for each menu to be cooked), the LSI causes the unit to stop sensor cooking; thereafter, the unit goes in the next operation automatically.

When the LSI starts to detect the initial voltage at AN7 terminal 16 seconds after the unit has been put in the Sensor Cooking mode, if it is not possible to balance the bridge circuit due to disconnection of the absolute humidity sensor, ERROR will appear on the display and the cooking is stopped.

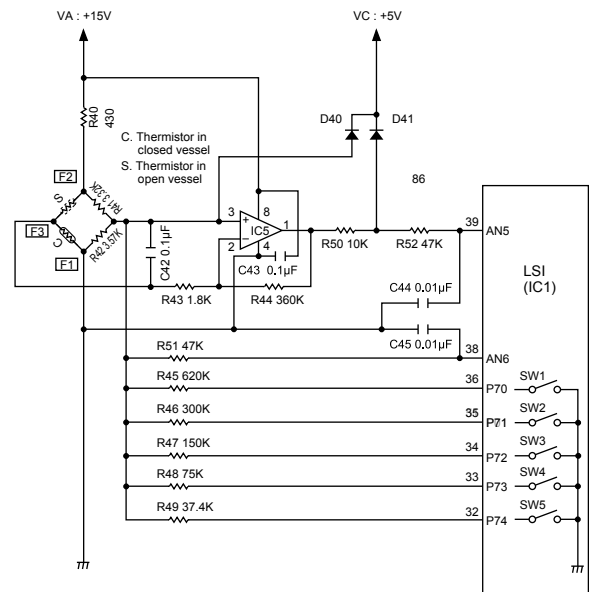

COMPONENT REPLACEMENT AND ADJUSTMENT PROCEDURE

WARNING AGAINST HIGH VOLTAGE:

Microwave ovens contain circuitry capable of producing very high voltage and current. Contact with the following parts may result in severe, possibly fatal, electric shock.

(Example)

High Voltage Capacitor, Power Transformer, Magnetron, High Voltage Rectifier Assembly, High Voltage Harness etc..

WARNING: To Avoid possible exposure to microwave energy, please follow the instructions below before servicing the oven.

- | | |
|--|--|
| <ol style="list-style-type: none"> 1. Disconnect the power supply cord. 2. Make sure that a definite "click" can be heard when the microwave oven drawer is unlatched. (Hold the drawer in a closed position with one hand, then pull the drawer open, this causes the latch leads to rise, it is then possible to hear a "click" as the drawer switches operate.) 3. Visually check the drawer and cavity face plate for damage (dents, cracks, signs of arcing etc.). | <ol style="list-style-type: none"> 1. Drawer does not close firmly. 2. Drawer latch hook is damaged. 3. The drawer gasket or seal is damaged. 4. The drawer is bent or warped. 5. There are defective parts in the drawer interlock system. 6. There are defective parts in the microwave generating and transmission assembly. 7. There is visible damage to the oven. |
|--|--|

Carry out any remedial work that is necessary before operating the oven.

Do not operate the oven if any of the following conditions exist:

Do not operate the oven:

1. Without the RF gasket (Magnetron).
2. If the wave guide or oven cavity are not intact.
3. If the drawer is not closed.

WARNING FOR WIRING

To prevent an electric shock, take the following precautions:

1. Before wiring:
 - 1) Disconnect the power supply cord.
 - 2) Open the drawer.
 - 3) Wait 60 seconds, then discharge the high voltage capacitor.
2. Don't let the wire leads touch to the following parts:
 - 1) High voltage parts:
Magnetron, High voltage transformer, High voltage capacitor and High voltage rectifier assembly.
 - 2) Hot parts:
Oven lamp, Magnetron, High voltage transformer and Oven cavity.

MICROWAVE DRAWER DISASSEMBLY

WARNING: Follow all safety precautions as stated at the beginning of this Service Manual before proceeding!

1. Open the Drawer to access the **(4)** mounting screws holding the unit on to the wall or cabinet opening. **(Fig 1)**.

2. Close Drawer and carefully pull the unit out from opening and unplug the power supply cord. Place unit on a secured surface to work on.

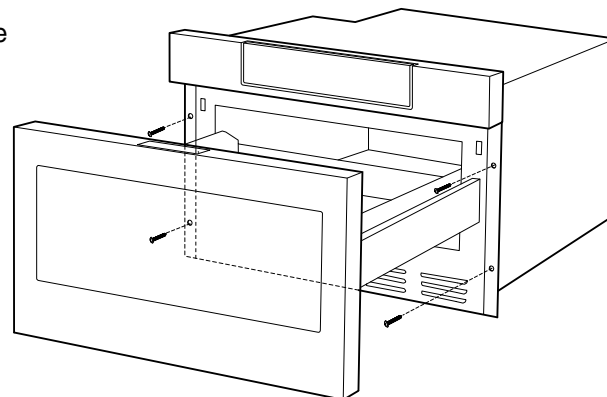

Fig. 1

3. Remove the **(2)** screws holding AC Cord Mounting Angle. Lift the mounting angle (with AC Cord attached) and unplug AC Cord from molex. **(Fig 2)**.

4. Remove the **(18)** screws holding the Control Panel Rear Cover, Outer Case/Side Angles, then remove outer Case. **(Fig 2)**.

5. Remove the **(10)** screws holding the Back Plate.

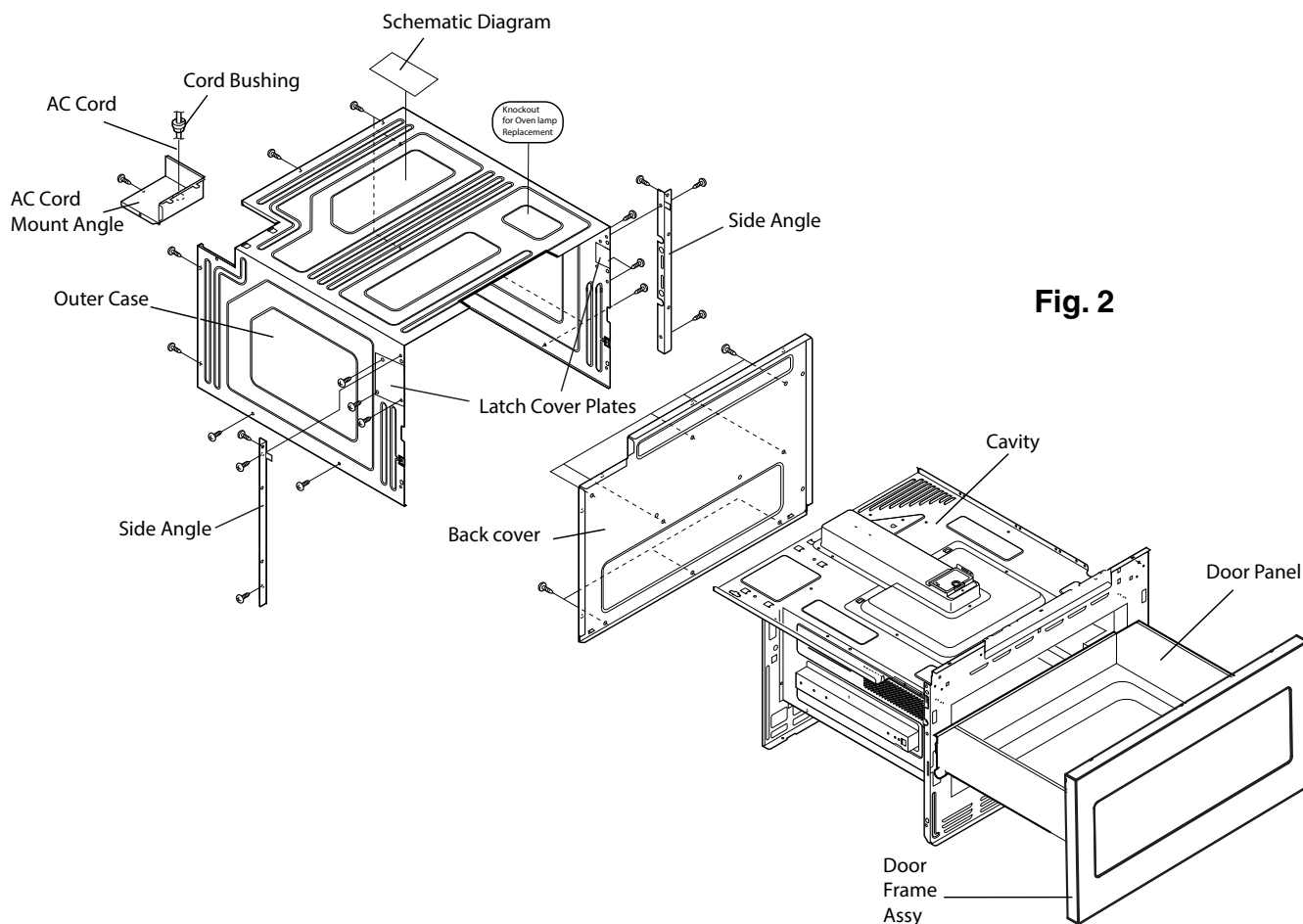

Fig. 2

NOTE: You now have access to all components of the Drawer.

CONTROL PANEL (C/P) REMOVAL

1. Open Door (**Fig 3**)
2. Remove side angles (R & L)
3. Remove 6 C/P cover screws (remove cover).
4. Lift C/P Assy up and tilt down to remove.
5. Careful not to scratch Faceplate and/or C/P, hold C/P facing down, open Hidden C/P, then unplug Molex Harness from CPU.

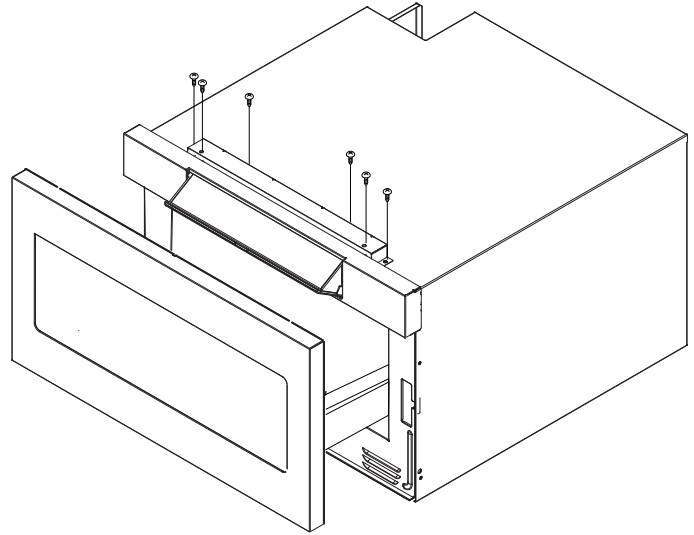

Fig. 3

CPU REMOVAL

6. With C/P laying on protected surface and Hidden C/P open, remove 2 screws from CPU and remove board (**Fig 4**).

C/P BREAK DOWN

7. Remove 5 screws from bottom of C/P Decoration (**Fig 4**).
8. Carefully lift Hidden C/P Hinge Assy (with Bottom Mount Insert) from C/P decoration.

AT THIS POINT, YOU ACCESS TO ALL HIDDEN C/P HINGE ASSY COMPONENTS

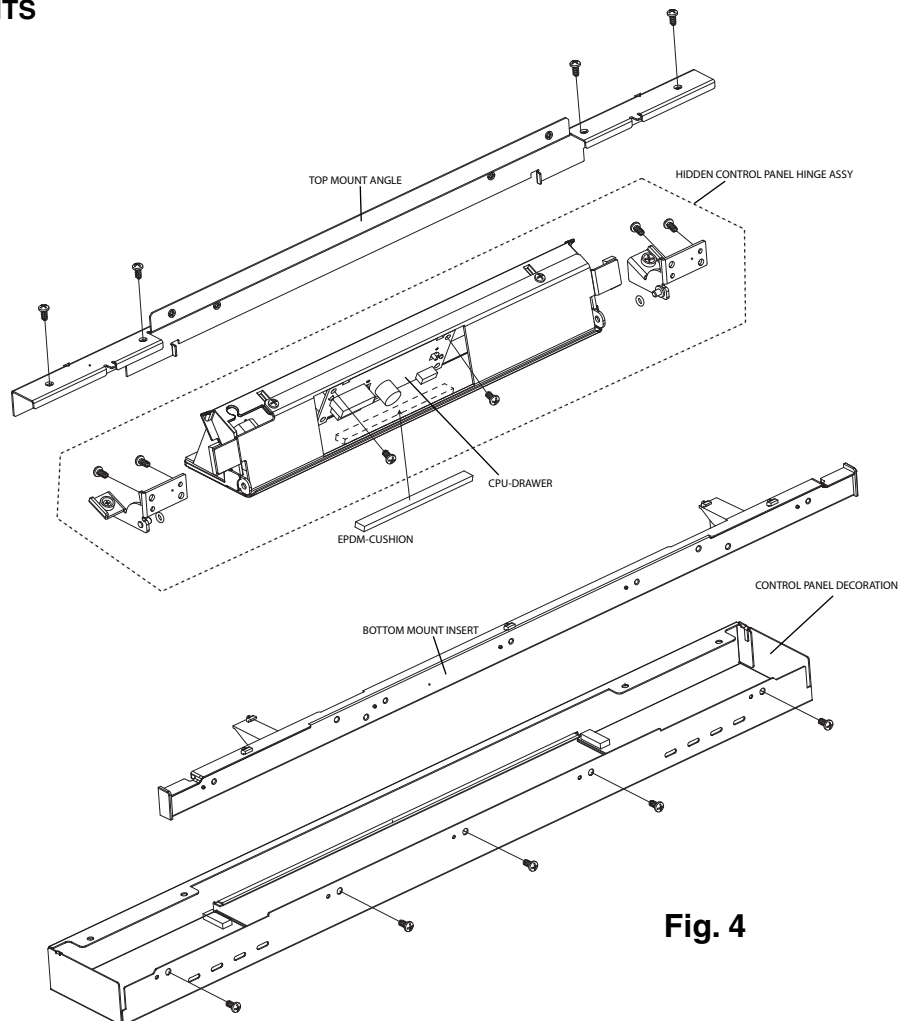
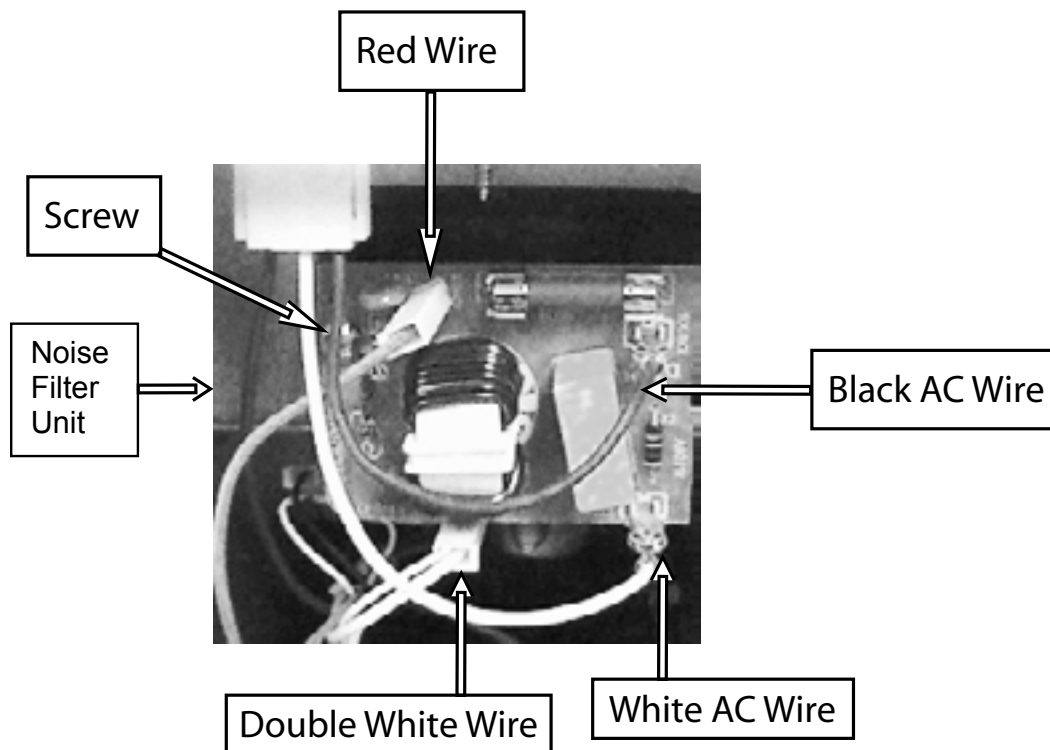

Fig. 4

NOISE FILTER BOARD REPLACEMENT

1. Un-hook the black and white AC terminals from the Noise Filter PWB, plus the Red and double White terminals (**Fig 4**).
2. Remove the **(1)** screw holding the Noise Filter (**Fig 4**).
3. Reverse order to reinstall.

Fig. 4



STOP SWITCH, SECONDARY INTERLOCK SWITCH AND MONITOR SWITCH REMOVAL

1. Follow the Microwave Drawer disassembly as previously stated
2. Open the drawer and keep it open.
3. To discharge the high voltage capacitor, wait for 60 seconds.
4. Disconnect the wire leads of each switch.
5. Remove the screw holding the latch hook to the oven flange.
6. Remove the latch hook from the oven flange.
7. Remove each switch from the latch hook by pushing the one (1) stopper tab holding each switch.
8. Now, each switch is free.

Re-install

1. Re-install each switch in its place. The secondary interlock switch is in the lower position and the monitor switch is in the top position, located on the left side of the unit. The door sensing switch by itself on the right side of the unit.
2. Re-connect wire leads to each switch. Refer to pictorial diagram.
3. Secure the latch hooks with mounting screws to oven flange.
4. Make sure that the monitor switch is operating properly and check continuity of the monitor circuit. Refer to chapter "Test Procedure" and "Adjustment procedure".

Latch Hook Left



Latch Hook Right



STOP SWITCH, SECONDARY INTERLOCK SWITCH AND MONITOR SWITCH ADJUSTMENT

1. Follow the Microwave Drawer disassembly as previously stated
2. Open the drawer and keep it open.
3. To discharge the high voltage capacitor, wait for 60 seconds.
4. If the door sensing switch, secondary interlock switch and monitor switch do not operate properly due to a misadjustment, the following adjustment should be made.
6. Loosen the screw holding latch hook to the oven cavity flange.
7. With drawer closed, adjust latch hook by moving it back and forth, and up and down. In and out play of the door allowed by the upper and lower position of the latch hook should be less than 0.5mm. The vertical position of the latch hook should be adjusted so that the secondary interlock switch is activated with the drawer closed. The horizontal position of the latch hook should be adjusted so that the monitor switch and drawer sensing switch are activated with the drawer closed.
8. Secure the screws with washers firmly.
9. Check all of the switches operation.

After adjustment, check the following.

1. In and out play of door remains less than 0.5mm when in the latched position. First check upper position of latch hook, pushing and pulling upper portion of drawer toward the oven face. Then check lower portion of the latch hook, pushing and pulling lower portion of the door toward the oven face. Both results (play in the door) should be less than 0.5mm.
2. The secondary interlock switch interrupts the circuit before the door can be opened.
3. Monitor switch contacts close when door is opened.
4. Door sensing switch contacts open when door is opened.
5. Reassemble the unit and check for microwave leakage around door with an approved microwave survey meter. (Refer to Microwave Measurement Procedure.)

DRAWER/SLIDE RAIL REMOVAL

DRAWER ASSEMBLY AND CHOKE REMOVAL

1. Open the drawer, remove Oven Tray and keep it open.
2. Remove (2) Drawer Support Covers from Choke Cover as shown in **(Fig. D-1)**.
3. Remove (4) screws from both Door Support Angles A as shown in **(Fig. D-2)**.
4. Unhook bottom Door Support Angle B from drawer by moving black inside lever to the side to release the drawer from the Slide rail by pulling it out **(Fig. D-3)**.
5. The Drawer assembly is free and the Choke Cover can now be removed.

DOOR SUPPORT ANGLE REMOVAL

1. Remove Drawer Assembly and Choke Cover as stated in "DRAWER ASSEMBLY AND CHOKE REMOVAL".
2. Remove Outercase Cabinet to access the Door Stoppers on the Door Support Angles A **(Fig. D-5)**.
3. Unhook Door Support Angle A from drawer by moving black inside lever to the side to release the drawer from the Slide rail by pulling it out
4. Remove (2) inside screws/nuts from right or left Door Support Angle/Slide Rail, then remove Slide Rail **(Fig. D-6)**.
5. To replace Rack Gear, remove Door Support Angle B from Door panel, then remove (3) screws holding Rack Gear on **(Fig. D-4)**.

To reassemble, just reverse the above order.

After reassembly, do the following.

- (A) Make sure that drawer sensing switch, secondary interlock switch and monitor switch are operating properly **(Fig. D-7)**.
- (B) An approved microwave survey meter should be used to assure compliance with proper microwave radiation emission limitation standards.

After any servicing, make sure of the following :

1. Drawer latch heads smoothly catch latch hook through latch holes and that latch head goes through center of latch hole .
2. Deviation of door alignment from horizontal line of cavity face plate is to be less than 1.0mm.
3. Drawer is positioned with its face pressed toward cavity face plate.
4. Reassemble the unit and check for microwave leakage around drawer with an approved microwave survey meter. (Refer to Microwave Measurement Procedure.)

Fig. D-1

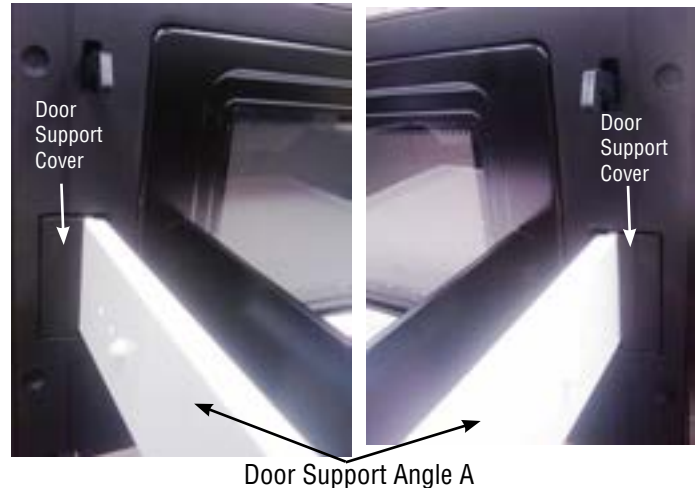

Door Support Angle A

Fig. D-2

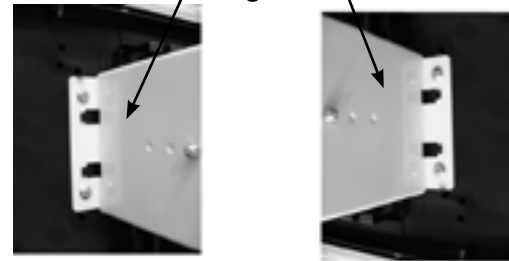
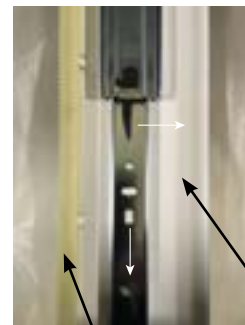

Fig. D-3



Rack Gear

Fig. D-4



Door Support Angle B

Fig. D-7



Fig. D-5

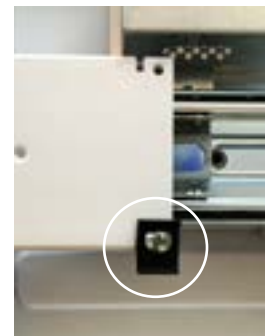

Fig. D-6



DOOR LATCH REMOVAL

1. Follow "DRAWER ASSEMBLY AND CHOKE REMOVAL" (steps 4-9)
2. Lay the door panel & door frame assembly front down on a protective surface.
3. Remove the **(11)** screws holding door panel to door frame (**Fig. L-1**).
4. With the door frame removed, unhook latch/s spring, then remove screw.
5. Proceed in reverse to reinstall.
6. Adjust switches after assembled back to the cavity.

Fig. L-1

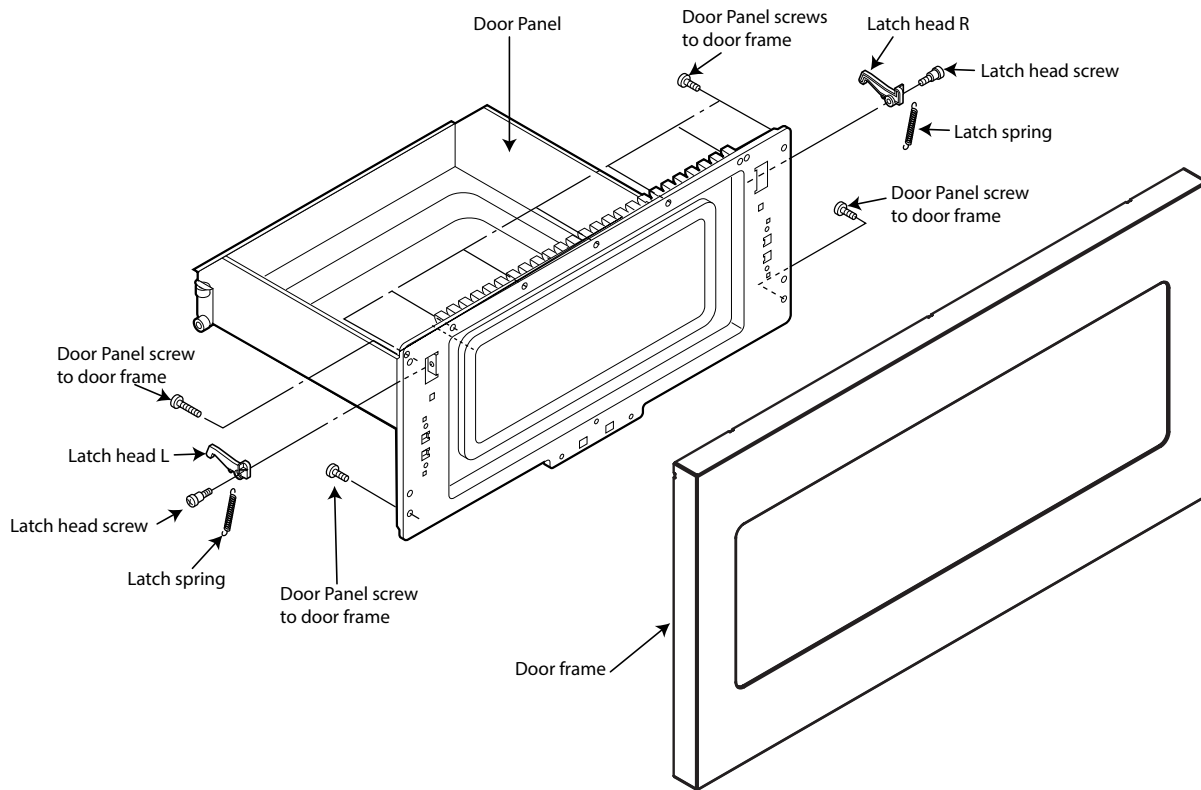

Note: The drawer on a microwave oven is designed to act as an electronic seal preventing the leakage of microwave energy from oven cavity during cook cycle. This function does not require that door be air-tight, moisture (condensation)-tight or light-tight. Therefore, occasional appearance of moisture, light or sensing of gentle warm air movement around oven drawer is not abnormal and do not of themselves indicate a leakage of microwave energy from oven cavity.

AUTO DRAWER GEAR REMOVAL/INSTALLATION

(This procedure can be performed without removing the outercase)

1. If you are just replacing the Auto drawer Gear, it will not be necessary to follow the "Microwave Drawer Disassembly" as previously stated.
2. Turn the Drawer up on its back and knockout the Auto Drawer Gear hole cover (**Fig. G-1**).
3. Unhook wiring connector to Auto Drawer Gear motor.
5. Remove the (4) screws holding the auto drawer gear to the bottom cavity angle (**Fig. G-2**).
6. Disengage (pull) Auto Drawer Gear motor from rack gear.
7. The Auto Drawer Gear motor is now free.

Installation:

1. Proceed in reverse to reinstall the Auto Drawer Gear motor taking care that the gear teeth are set into the cavity angle correctly before tightening screws .
2. After Auto drawer Gear is reinstalled, insert the hole cover in reverse order so that it can be secured with a XOTS740P12000 common screw.



Fig. G-1



Fig. G-2

RACK GEAR / OIL DAMPER REMOVAL/INSTALLATION

1. Follow the Microwave Drawer disassembly as previously stated.
2. Open the drawer and keep it open.
3. To discharge the high voltage capacitor, wait for 60 seconds.
4. Remove the Microwave Drawer by following steps under "DRAWER SUPPORT ANGLE REMOVAL".
5. Remove the (3) screws holding the Rack Gear to the bottom slide rail (**Fig. G-3**).
6. With the bottom slide rail off, locate tab holding Oil Damper and remove, then replace with new one (**Fig. G-4**).
7. Proceed in reverse to reinstall the new Rack Gear. and/or Oil Damper.



Fig. G-3

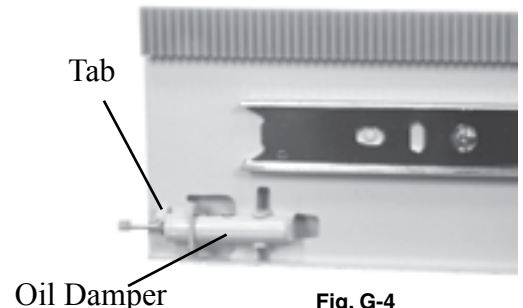
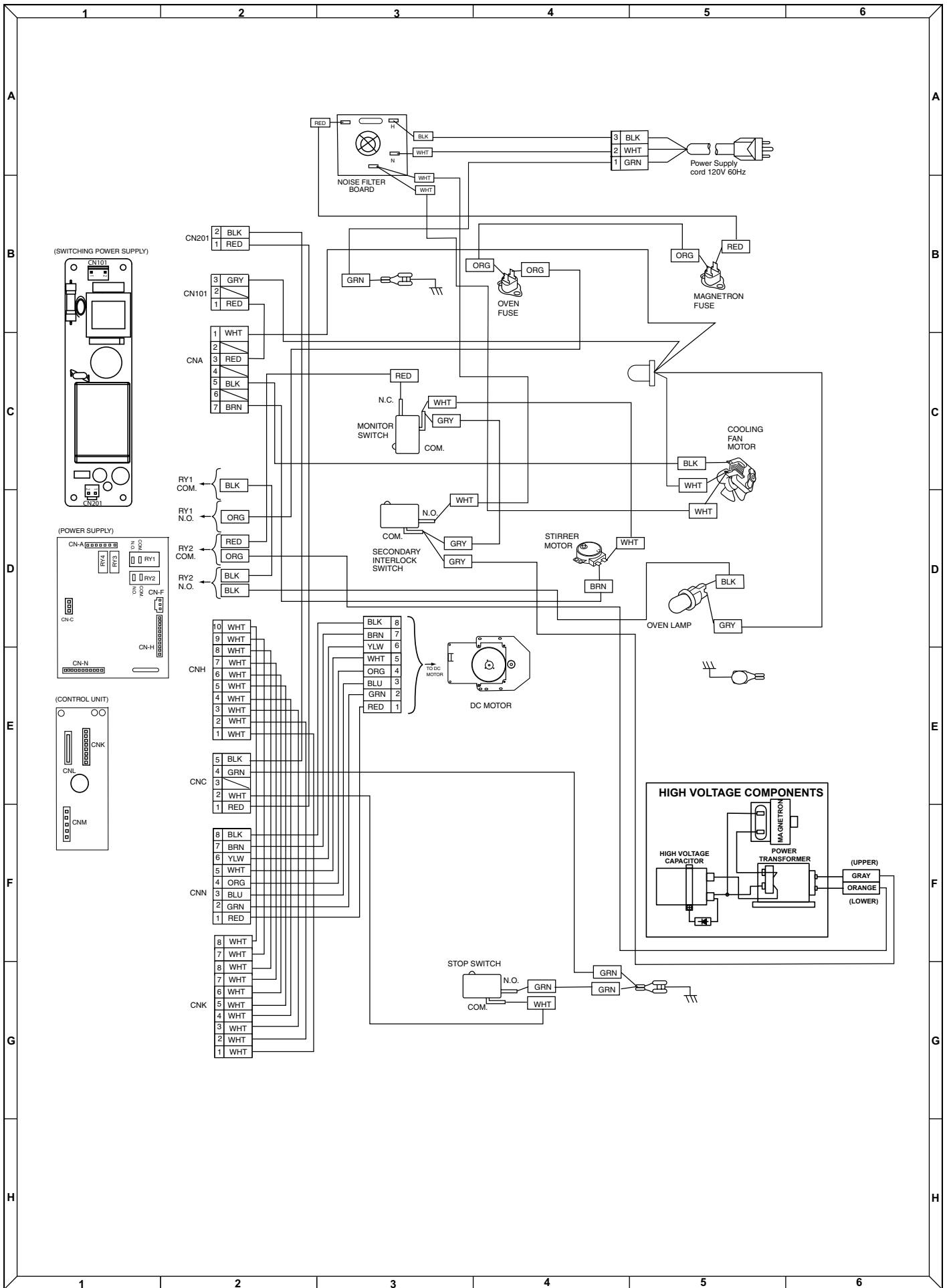

Fig. G-4

OIL DAMPER INFORMATION

The "Oil Damper" helps the drawer from closing too hard.



PARTS LIST

REF. NO.	PART NO.	DESCRIPTION	Q'TY	CODE
ELECTRICAL PARTS				
1-1	FC-QZA637WRKZ	HVC ASSY	1	AM
1-2	DPWBF235MRU0	PSU- Drawer	1	BB
1-3	DPWB-B383DRKZ	SW PSU- Drawer	1	BE
1-4	FACDCB021MRE0	POWER SUPPLY CORD	1	AP
1-5	FDTCTA240WRKZ	SENSOR ASSY	1	AQ
1-6	FMOTEB062MRK0	FAN MOTOR ASSY	1	AD
1-7	FPWBFA512WRKZ	Noise Filter Unit	1	AN
1-8	FFS-BA018/KIT	MONITOR FUSE (V-5220Q) WITH FUSE (20A) ASSEMBLY	1	AF
1-9	RLMPTA099WRZZ	OVEN LAMP WITH SOCKET	1	AE
1-10	RMOTDA283WRZZ	STIRRER MOTOR	1	AM
1-11	QFS-TA013WRE0	OVEN/MG DM FUSE	2	AH
1-12	RTRN-B101MRE0	TRANSFORMER	1	BD
1-13	RV-MZA365WRZZ	MAGNETRON	1	AZ
1-14	FW-VZC424WREZ	DRAWER HARNESS	1	BC
1-15	QSW-MA168WRZZ	Secondary interlock switch / Door sensing switch	2	AE
1-16	FANGTB020MRK1	AUTO DRAWER GEAR ASSY	1	BL
CABINET PARTS				
2-1	GCABUB314WRPZ	OUTER CASE CABINET	1	AM
2-2	LANGQA830WRPZ	AC CORD MOUNT ANGLE	1	AM
2-3	LANGTB363MRT0A	SIDE ANGLE L	1	AK
2-4	LANGTB364MRT0A	SIDE ANGLE R	1	AK
2-5	LBSHCA014WRE0	CORD BUSHING	1	AB
2-6	PCOVPA670WRPZ	LATCH COVER	2	AB
CONTROL PANEL PARTS				
3-1	DPWBF240MRU0	CPU- Drawer	1	BA
3-2	DPNLCB220MRK0	HIDDEN CONTROL PANEL HINGE ASSY	1	BR
3-3	PMAG-B002MRE0A	MAGNETIC STRIP	1	AD
3-4	PMAG-B003MRE0A	ROUND MAGNET	2	AF
3-5	XEPS730P10XS0	M3 X 10 SCREW - STEEL P-TIGHT	2	AC
3-6	LX-CZB066MRE0	Screw- #4 x 1/3# Flathead SS	6	AA
3-7	LX-WZB040MRE0	O-Ring- 4mmID Rubber	2	AA
3-8	PCUSGB116MRP0	CUSHIONS	4	AB
3-9	FHNG-B058MRY0	CP HINGE ASSY LEFT	1	AH
3-10	FHNG-B057MRY0	CP HINGE ASSY RIGHT	1	AH
3-11	LX-CZB060MRE0	Screw- #8-18 3/8" PHILLIPS PAN	8	AA
3-12	LHLD-B053MRF0A	C/P BTM MOUNT INSERT	1	AK
3-13	LANGTB379MRP0	C/P TOP MOUNT ANGLE	1	AH
3-14	HDECAC004MRQ0	C/P DECORATION	1	AZ
3-15	LX-BZB073MRE0	M4 FLAT HEAD SCREW	2	AA
3-16	PCUSUB130MRP0	EPDM CUSHION	1	AB
OVEN PARTS				
4-1	LSTPPA332WRFZ	DOOR STOPPER	2	AK
4-2	FGLSPB005MRY0	OVEN TRAY ASSY	1	BH
4-3	*****	CAVITY ASSEMBLY (not replaceable parts)	1	-
4-4	FPLT-B002MRY0A	ANTENNA ASSY	1	AS
4-5	GCABDA202WRWZ	BACKPLATE	1	AM
4-6	GCOVHB066MRF0	DOOR SUPPORT COVER	2	AM
4-7	GDAI-A474WRWZ	BASE PLATE	1	AX
4-8	LANGTA584WRTZ	DOOR SUPPORT ANGLE A	2	AN
4-9	LANGTA585WRTZ	DOOR SUPPORT ANGLE B	1	AN
4-10	LBNDKA186WRPZ	HVC BAND	1	AB
4-11	LHLD-A352WRFZ	PSU HOLDER	1	AH
4-12	LHLD-A387WRFZ	SW PSU HOLDER	1	AD
4-13	MSLIFB006MRE0	SLIDE RAIL	3	AY
4-14	NGERB006MRF0	RACK GEAR	1	AP
4-15	PCLICA044WREZ	CANOE CLIP	4	AV
4-16	LANGTB380MRP0	C/P REAR COVER	1	AG
4-17	PCOVPA597WREZ	ANTENNA COVER	1	AB
4-18	PCOVPA590WRPZ	OVEN LAMP COVER	1	AM
4-19	PCUSGA807WRPZ	INLET CUSHION	2	AB
4-20	PCUSGA808WRPZ	HVT CUSHION	1	AC
4-21	PCUSGA809WRPZ	EXHAUST DUCT CUSHION	1	AR

REF. NO.	PART NO.	DESCRIPTION	Q'TY	CODE
4-22	PCUSGA851WRPZ	FAN MOTOR SUPPORT CUSHION	1	AC
4-23	PCUSGA810WRPZ	AIR FLOW CUSHION	1	AT
4-24	PCUSUA687WRPZ	CUSHION	1	AD
4-25	PDMP-B003MRE0	OIL DAMPER	1	AC
4-26	PDUC-B141MRP0A	MAG DUCT	1	AE
4-27	PDUC-B191WRFZ	SENSOR DUCT	1	AR
4-28	PDUC-B192WRFZ	EXHAUST DUCT	1	AR
4-29	PFILWA066WRPZ	LAMP FILTER	1	AB
4-30	PSKR-A516WRPZ	PARTITION AG BOTTOM	1	AM
4-31	PSKR-A517WRWZ	PARTITION AG REAR	1	AM
4-32	PHOK-A178WRFZ	LATCH HOOK R	1	AG
4-33	PHOK-A174WRFZ	LATCH HOOK L	1	AG
4-34	PCOVPA667WRPZ	FACEPLATE OUTERCASE COVER	1	AR

DOOR PARTS

5-1	FCOV-B551MRK0	DOOR FRAME ASSY	1	BQ
5-2	FDORFA531WRYZ	DOOR PANEL ASSY	1	BK
5-3	LSTPPB072MRFO	LATCH HEAD R	1	AD
5-4	LSTPPB073MRFO	LATCH HEAD L	1	AD
5-5	MSPTB035MRE0	LATCH SPRING	2	AD
5-6	PSHEPB255MRE0	SEALER FILM	1	AM
5-7	LX-HZB001MRE0	SPECIAL SCREW	2	AA
5-8	XCPS740P08000	M4 X 8 SCREW - TAP PAN HEAD	11	AA
5-9	GCOVHB067MRFO	CHOKE COVER	1	AY

MISCELLANEOUS

6-1	TINSEB546MRR2	OP MANUAL ASSY	1	AE
6-2	TINSEB539MRR4	INSTALLATION INSTRUCTIONS	1	AC
6-3	LX-CZB055MRE0	WOOD SCREW (M4 X 20, PANHEAD)	4	AA
6-4	TCAUAA387WRRZ	DHHS/GRD/CAUTION LABEL	1	AD
6-5	TCAUAB050MRR0	MONITOR CAUTION LABEL	2	AD
6-6	TCAUAB059MRR0	CONSUMER WARNING LABEL	1	AA
6-7	TCAUHA412WRRZ	USER CAUTION LABEL	1	AA
6-8	TCAUAA392WRRZ	WAVEGUIDE COVER CLEANING LABEL	1	AA
6-9	TLAB-B105MRR0	MENU LABEL	1	AB
6-10	TMAPCA825WRRZ1	SCHEMATIC DIAGRAM	1	AC

SCREWS, NUTS, AND WASHERS

7-1	LX-BZA041WRE0	M4-POINTED-8	11	AA
7-2	LX-CZ0052WRE0	SCREW WITH WASHER	2	AA
7-3	LX-CZA084WREZ	SCREW	3	AA
7-4	LX-CZA107WREZ	SCREW WITH WASHER	2	AA
7-5	LX-NZB006MRE0	CAP NUT	2	AA
7-6	LX-NZB012MRE0	CAP NUT	4	AA
7-7	XCBS730P08000	M3 X 8 SCREW - TAP BINDING HEA	4	AB
7-8	XOTS740P12RV0	M4 X 12 SCREW - COMMON (RoHS)	8	AB
7-9	XEPS730P10XS0	M3 X 10 SCREW - STEEL P-TIGHT	7	AC
7-10	XHPS740P08K00	SCREW: 4MM X 8MM	5	AB
7-11	XHTS740P06000	4x6mm SCREW	2	AC
7-12	XHTS740P08000	M4 X 8 SCREW - T TAP TRUSS (Ro	5	AD
7-13	XOTS740P12000	CABINET SCREW/ CLEAR (RoHS)	58	AB

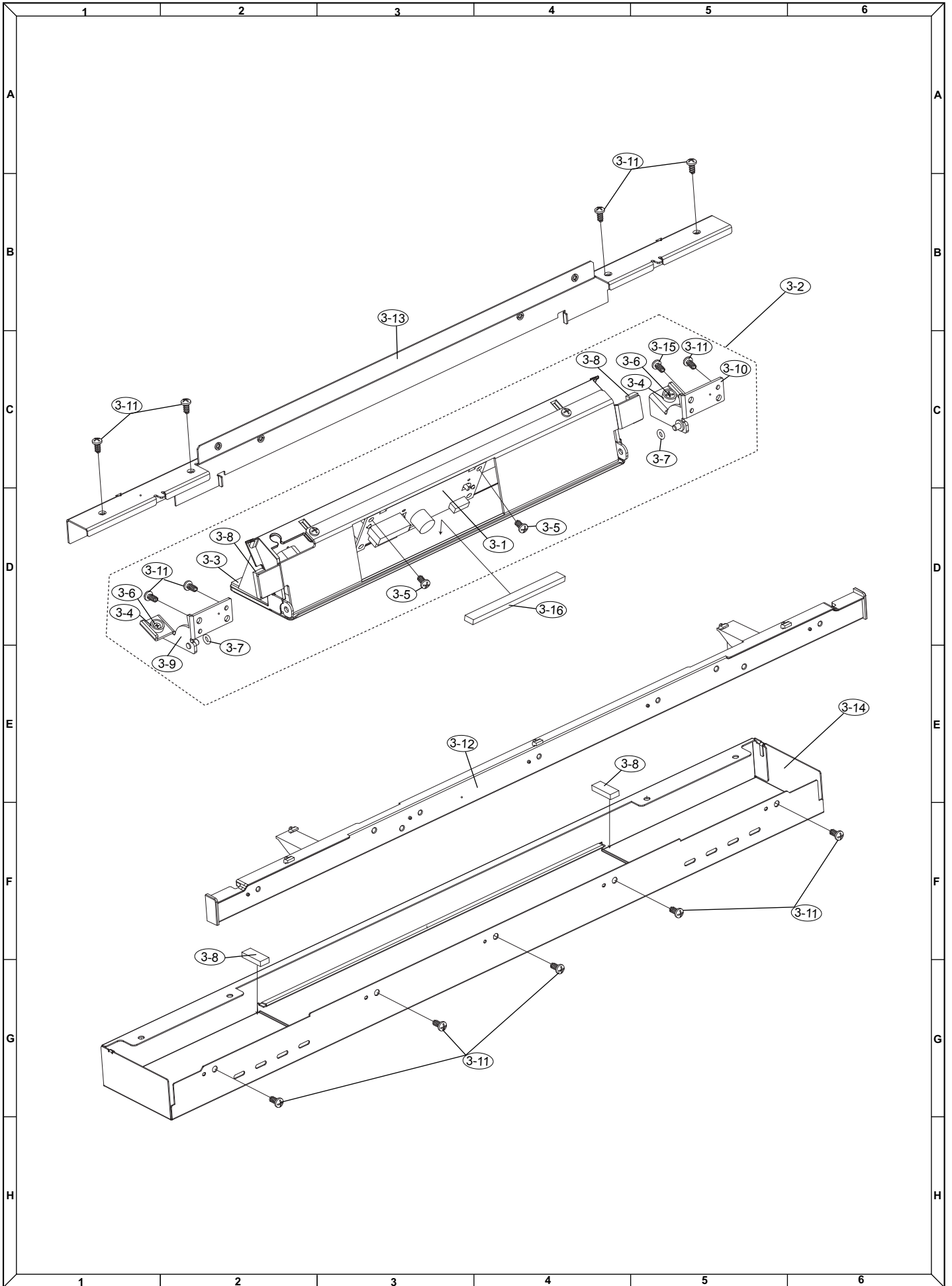

DRAWER

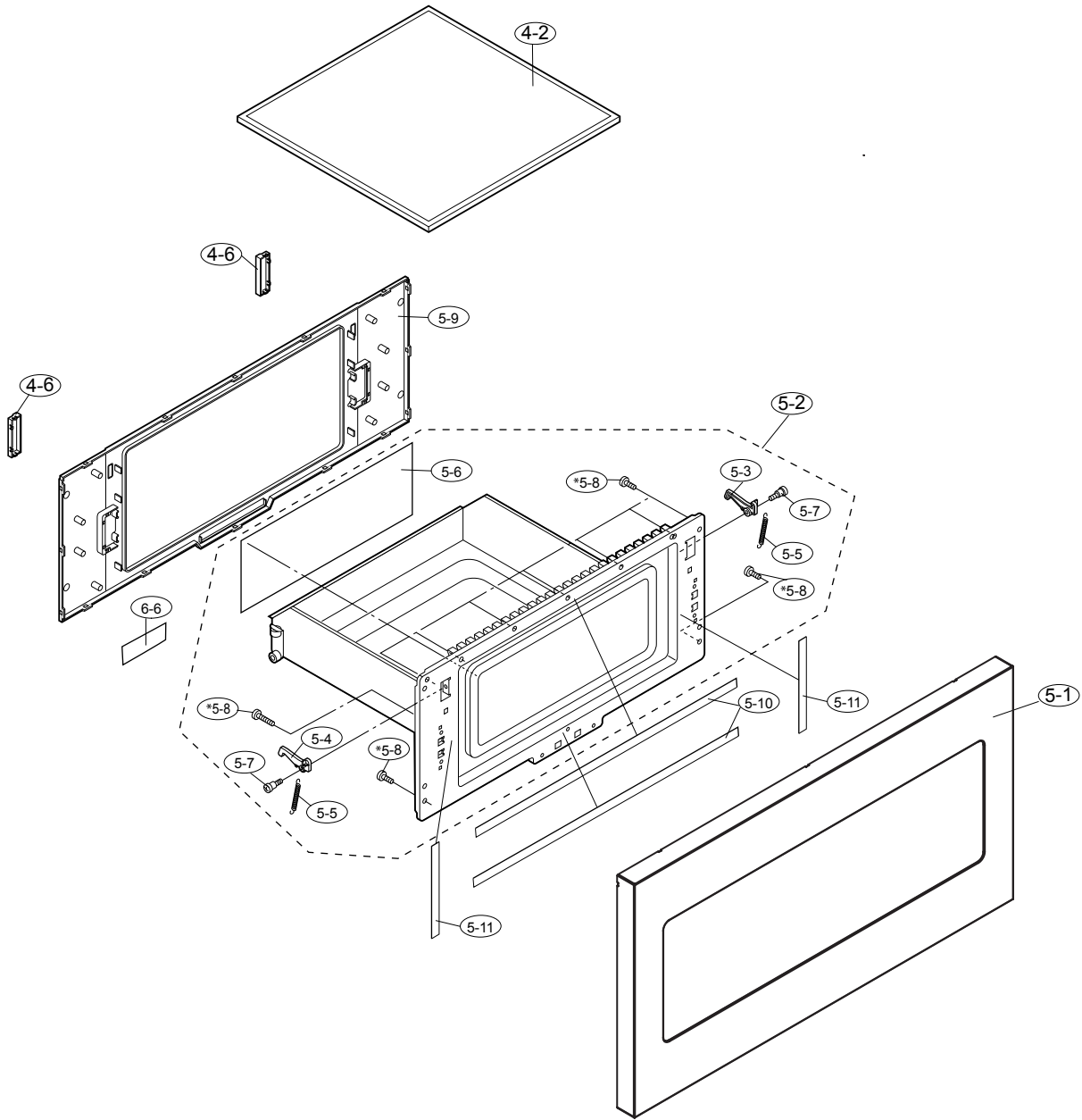

*NOTE: Screws 5-8 not included with 5-2

DRAWER CAVITY

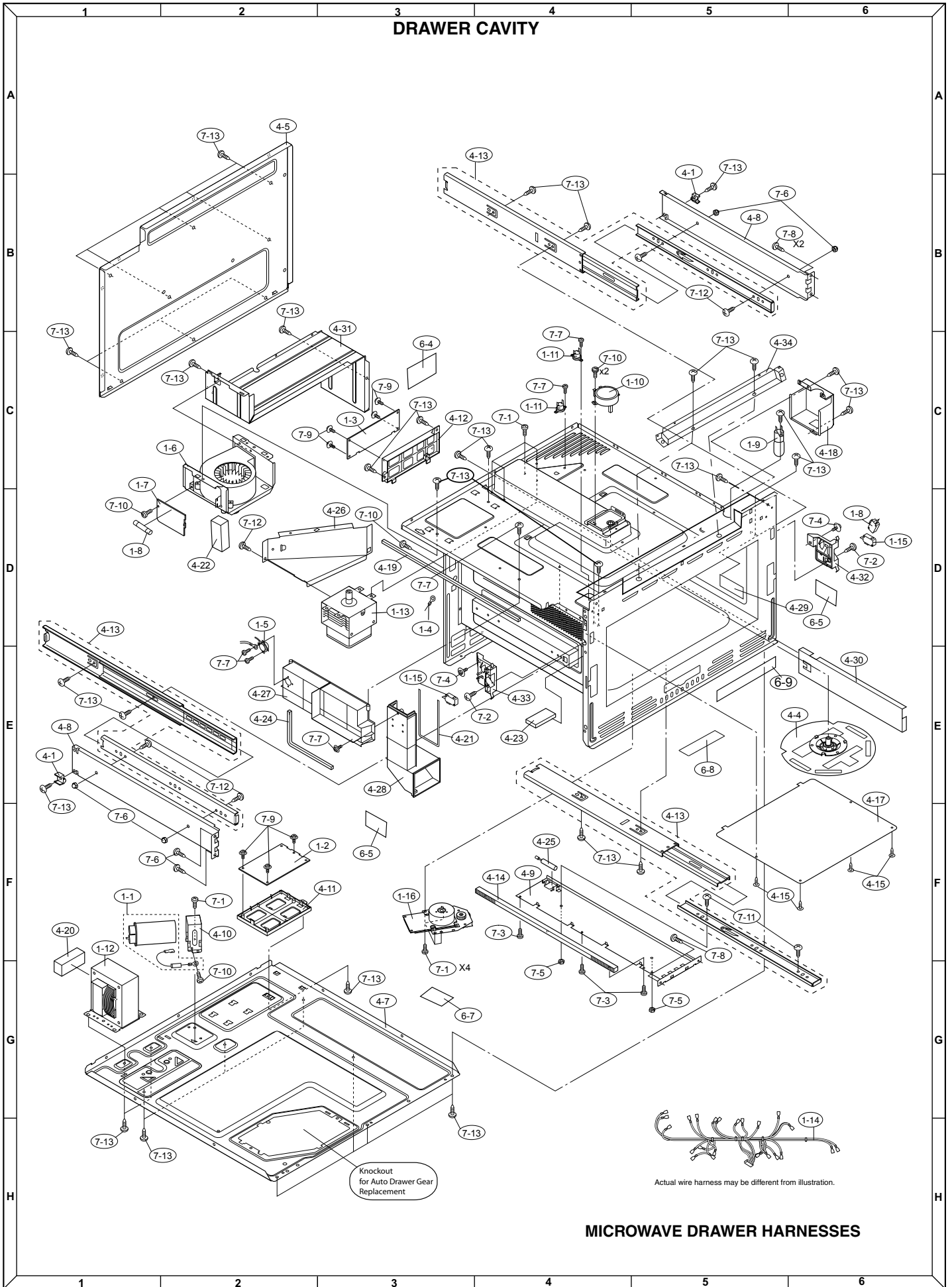

MICROWAVE DRAWER HARNESSSES

PACKING PARTS

● Non-replaceable items

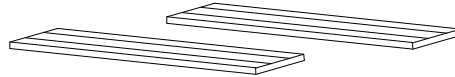
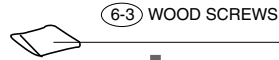
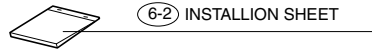
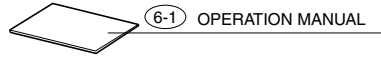

SUPPORT CORNERS ●

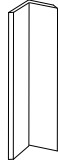

CROSS SUPPORTS ●



SUPPORT CORNERS ●

TOP FOAM ●

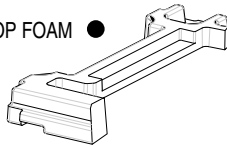

SUPPORT CORNERS ●

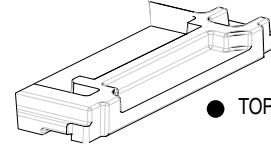
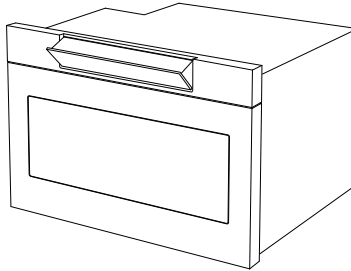

TOP FOAM ●

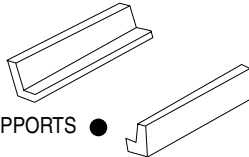

DRAWER SUPPORTS ●

SUPPORT CORNERS ●

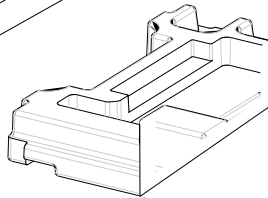

BOTTOM FOAM ●

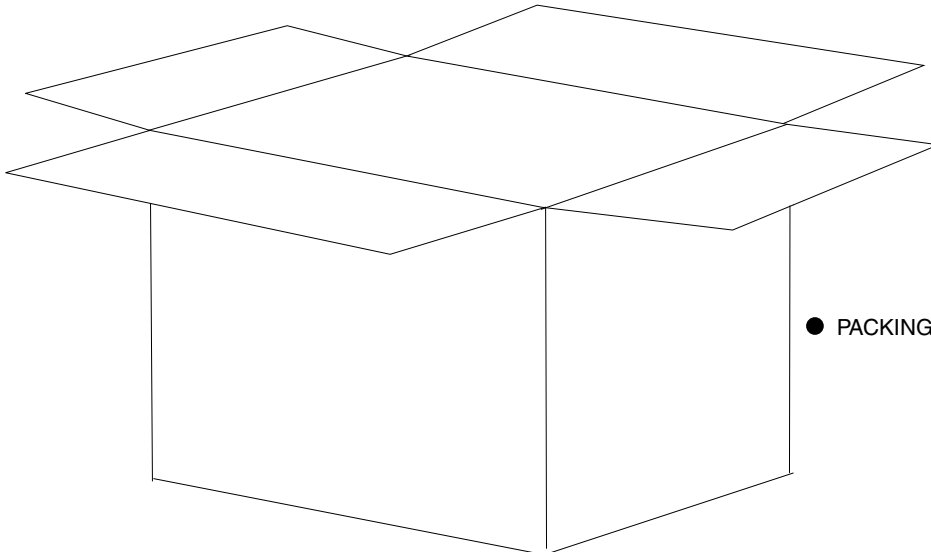
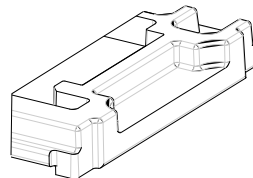

● PACKING CASE

SHARP

COPYRIGHT © 2017 BY SHARP CORPORATION

ALL RIGHTS RESERVED.

No part of this publication may be reproduced, stored in retrieval systems, or transmitted in any form or by any means, electronic, mechanical, photocopying, recording, or otherwise, without prior written permission of the publisher.