

Hisense

Refrigerator Service Manual

Model:

RQ-72WC1SHA(BCD-553WPZ)

HQD20*****



WARNING:

This service information is designed to be used ONLY by experienced repair technicians and is not designed for use by the general public. It does not include Warnings and Cautions to advise non-technical individuals of potential dangers in attempting to service a product. Products powered by electricity and/or use gas refrigerant should be serviced or repaired only by experienced professional technicians. Any attempt to service or repair the product or products covered in this service manual by anyone without this knowledge and experience could result in serious injury or death.

Table of Contents

SAFETY	3
MODEL SPECIFICATIONS.....	4
PARTS IDENTIFICATION.....	5
Refrigerator Parts.....	5
Air Flow Path	6
Evaporator Structure	7
Compressor Compartment Structure.....	8
OPERATION.....	9
Display Controls.....	9
Door Leveling and Alignment.....	10
Defrost Mode	11
TROUBLESHOOTING CHARTS	12
Error Code Summary	12
Humidity Sensor Error.....	13
Other Sensor Errors.....	14
Communication Error	15
Basic Troubleshooting.....	15
Start Fault.....	17
Freezer Compartment Temperature	18
Refrigerator Compartment Temperature	19
Thick Frost in Freezer Compartment	20
Moisture in Refrigerator Compartment	20
Crisper Temperature.....	21
Light Function	21
Noise	22
WIRING DIAGRAM.....	24
COMPONENT TESTING AND DISASSEMBLY	25
Main Board.....	25
Compressor	26
PTC Starter and OverLoad Protector (OLP).....	27
Fan Motor	28
Damper.....	30
Light	31
Door Switch.....	32
Temperature Fuse and Defrost Heater.....	33
Ice Maker and Water Pipe	34
Ice Maker Water Valve	35
REFRIGERANT SYSTEM REPAIR	36
Refrigeration System	36
Repair Summary	37
Repair Regulations.....	38
Repair Process.....	39
EXPLODED VIEWS/PARTS LIST.....	42

1. Safety

Please read the following Safety information before servicing this refrigerator.

General Service Precautions

- Disconnect power before handling any electrical components.
- Check the rated current, voltage, and capacity.
- Do NOT allow water to get near any electrical components.
- Use exact replacement parts.
- Remove any objects from the top of the cabinet before tilting the refrigerator.

Important Safety Instructions

WARNING: To reduce the risk of fire, electrical shock, injury to persons, or damage when using the refrigerator, follow basic precautions, including the following:

- Plug into a grounded 3 prong outlet.
- Do not remove ground prong.
- Do not use an adapter.
- Do not use an extension cord.
- Disconnect power before servicing.
- Replace all parts and panels before operating.
- Flammable refrigerant used. To be repaired only by trained service personnel. Do not puncture refrigerant tubing.
- Flammable refrigerant used. Dispose of properly in accordance with federal or local regulations.
- Flammable refrigerant used. Follow handling instructions carefully. Risk of fire or explosion due to puncture of refrigerant tubing.
- Flammable refrigerant used. Do not use a torch when servicing the refrigerator.
- Use nonflammable cleaner.
- Keep flammable materials and vapors, such as gasoline, away from refrigerator.
- Use two or more people to move and install refrigerator.
- If your refrigerator is not being used, remove the doors. This will reduce the possibility of danger to children.

Read and Save These Instructions

WARNING:

This service information is designed to be used ONLY by experienced repair technicians and is not designed for use by the general public. It does not include Warnings and Cautions to advise non-technical individuals of potential dangers in attempting to service a product. Products powered by electricity and/or use gas refrigerant should be serviced or repaired only by experienced professional technicians. Any attempt to service or repair the product or products covered in this service manual by anyone without this knowledge and experience could result in serious injury or death.

2. Model Specifications

CONTENT	UNIT	VALUE
Voltage / Frequency	V/Hz	115/60
Rated current	Amps	2.5
Rated input power	Watts	350
Defrost power	Watts	260
Net capacity	Cu Ft	20
Net capacity Refrigerator compartment	Cu Ft	13
Net capacity Convertible compartment		3.5
Net capacity Freezer compartment	Cu Ft	3.5
Energy efficiency class		A+
Climate class (SN= 50-90°F, N=60-90°F, ST=60-100°F, T=60-109°F)		SN N ST S
Refrigerator compartment temperature	°F	34-45
Freezer compartment temperature	°F	-13-5
Freezer compartment star rating		4 Star
Energy consumption / 24 hours	kWh/24h	1.709
Freezing capacity / 24 hours	kg/24 h	10
Max noise level	dB(A)	43
Kind of coolant / Charge (R600a) / grammes	R / g	R600a / 57

3. Parts Identification

Refrigerator Parts

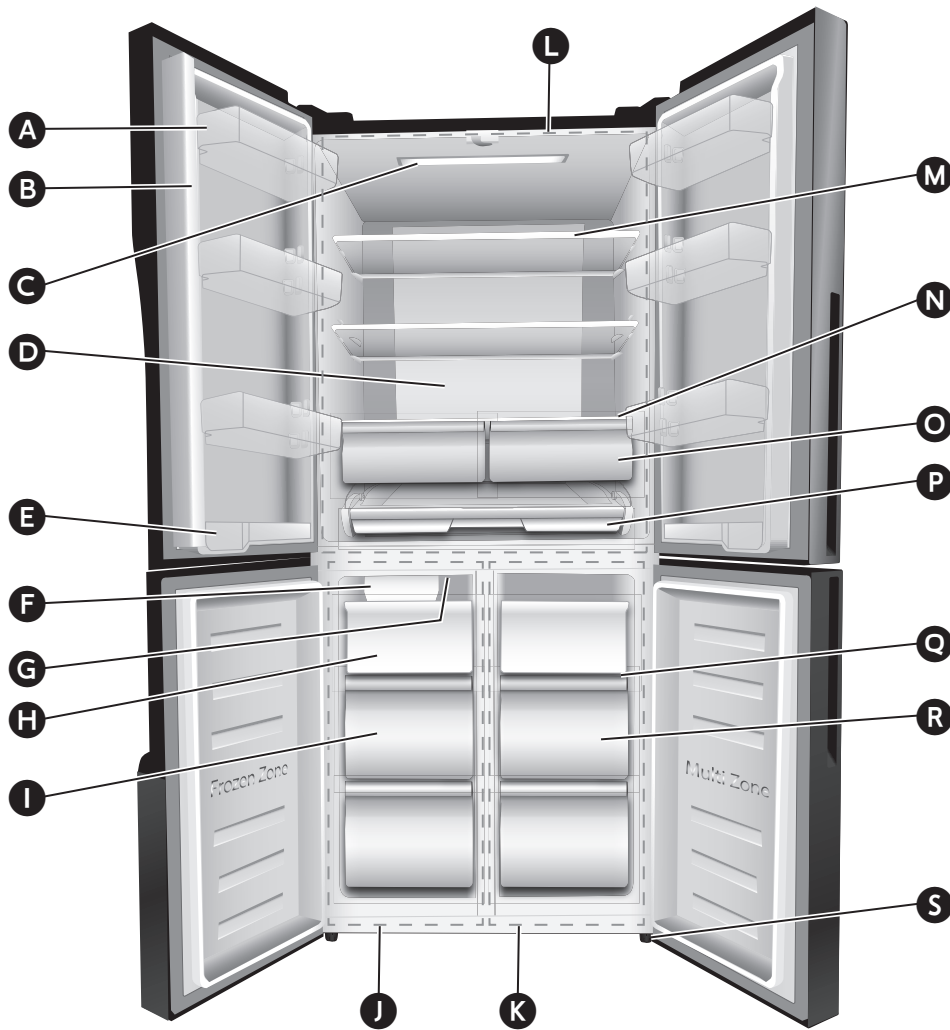

- A** Door Bin
- B** Mullion
- C** Refrigerator LED Light
- D** Air Duct Cover
- E** Door Tray
- F** Ice Maker

- G** Freezer LED Light
- H** Ice Storage Container
- I** Freezer Drawer
- J** Freezer Compartment
- K** Convertible Compartment
- L** Refrigerator Compartment
- M** Glass Shelf

- N** Cover
- O** Storage Drawer
- P** Full-width Drawer
- Q** Glass Shelf
- R** Convertible Drawer
- S** Leveling Leg

Air Flow Path

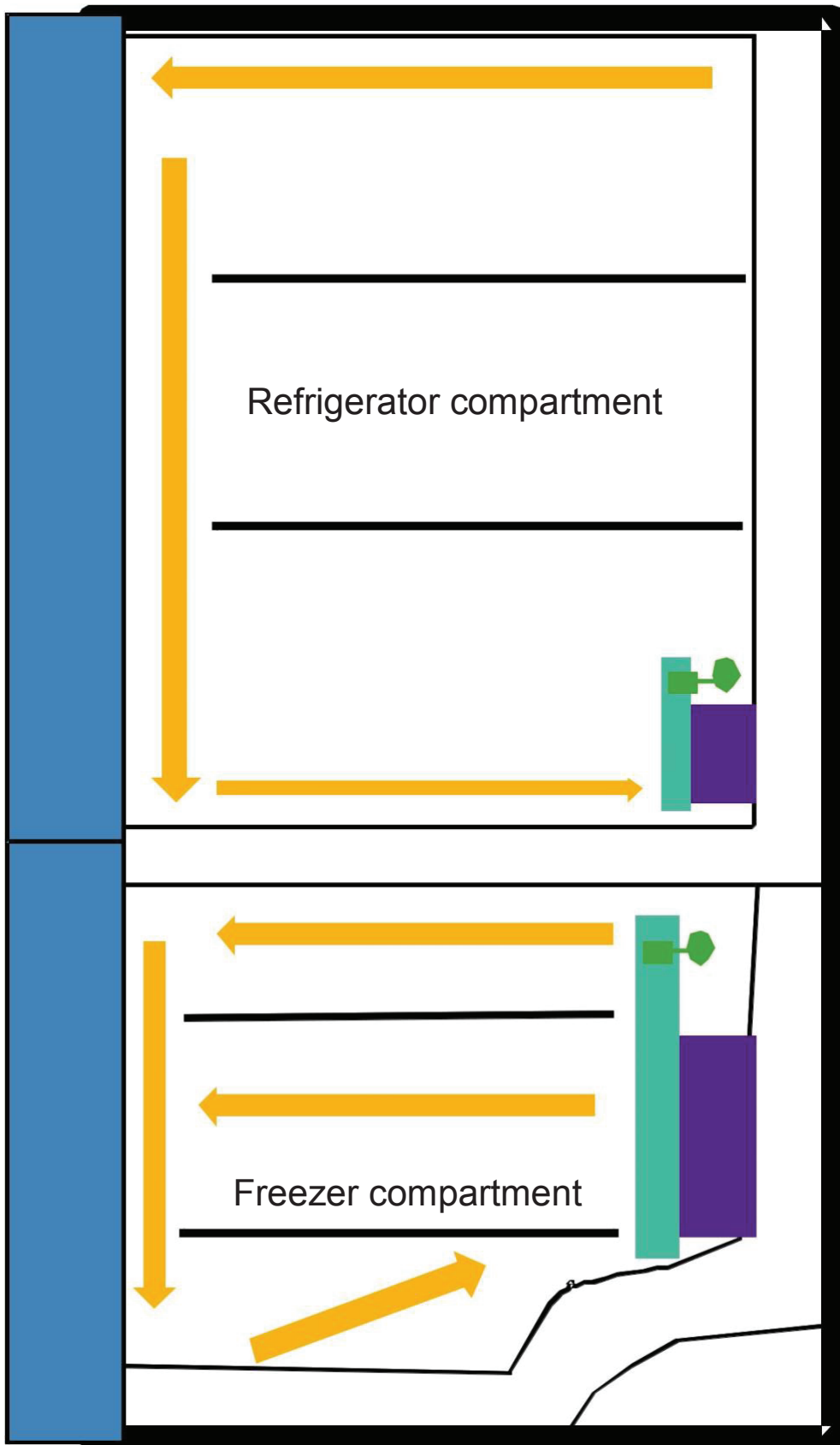

Evaporator Structure

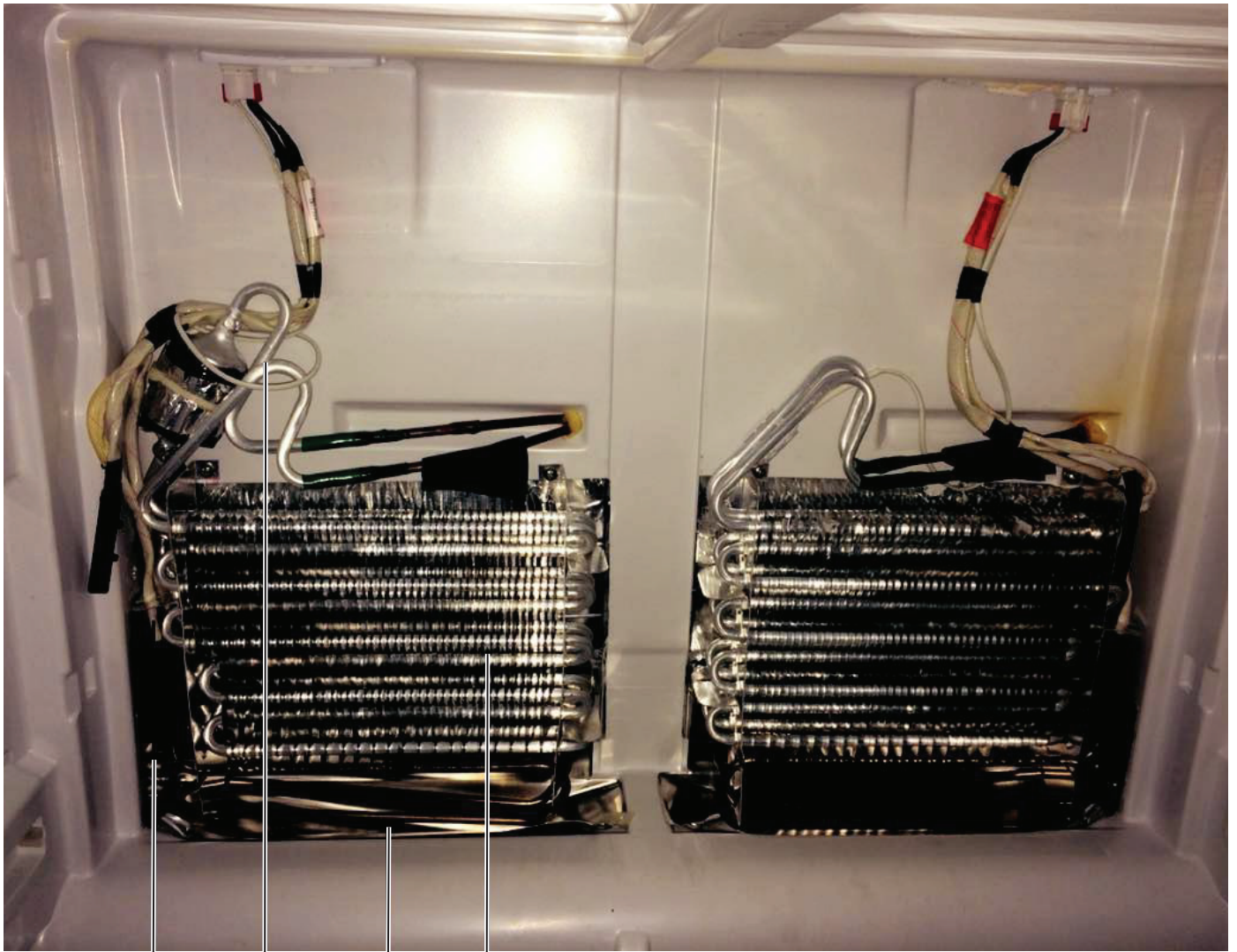

A

B

C

D

- A Fuse
- B Sensor
- C Heater
- D Evaporator

Compressor Compartment Structure

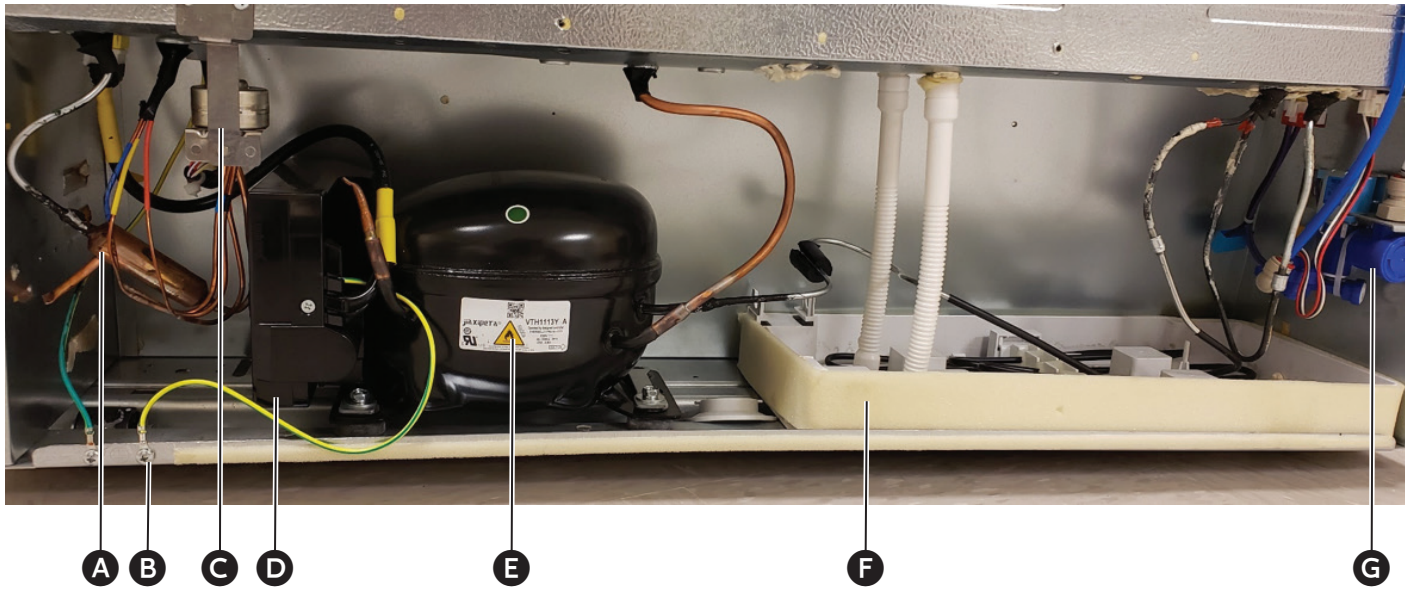

- A** Filter Dryer
- B** Ground Wire
- C** Refrigerant Switch
- D** PTC Starter
- E** Compressor
- F** Evaporation Tray
- G** Ice Maker Water Valve

4. Operation

Display Controls

NOTE: The controls on your model may look different from this and other images in this manual, depending on your model's features.

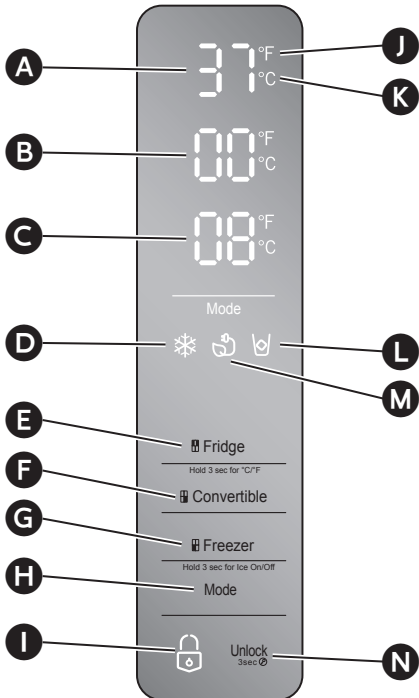

- A** Refrigerator Compartment Temperature
- B** Convertible Compartment Temperature
- C** Freezer Compartment Temperature
- D** Super Freeze Icon
- E** Refrigerator Temp Control
- F** Convertible Temp Control
- G** Freezer Temp Control
- H** Mode Control
- I** Lock/Unlock Icon
- J** Fahrenheit Indicator
- K** Celsius Indicator
- L** Ice Maker Icon
- M** Energy Saver Icon
- N** Unlock Control

Control Panel

The display will illuminate when the refrigerator is first plugged in, a control is pressed, or a door is opened. However the lights will automatically turn off after 60 seconds.

The Control Panel is locked, unless manually unlocked.

NOTE: When the control panel is locked, the Lock icon is illuminated.

To Unlock the Control Panel:

- Press and hold UNLOCK for 3 seconds.



NOTE: When the control panel is unlocked, the Unlock icon is illuminated.

Setting Compartment Temperatures

When you set a temperature, you are setting an average temperature for the entire compartment. The actual compartment temperatures may vary from the temperatures displayed depending on the amount and placement of stored food, and the surrounding room temperature.

Recommended Temperature Settings

- Refrigerator Compartment: 37°F (3°C)
- Convertible Compartment: 8°F (-13°C)
- Freezer Compartment: 0°F (-18°C)

Display Temperatures in Degrees Fahrenheit or Celsius

- Press and hold FRIDGE for 3 seconds.



NOTE: Either the °F or °C icon will illuminate to indicate in which scale (Fahrenheit or Celsius) the temperature is being displayed.

- Press FRIDGE again, to change the temperature scale.

Refrigerator (Fridge) Compartment Temperature

1. Press FRIDGE once to turn on the temperature control.



2. Press FRIDGE repeatedly to cycle through the available temperature settings, from 45°F to 34°F or from 7°C to 1°C.

NOTE: Each press advances the setting by one degree.

3. Release FRIDGE when the desired temperature setting appears.

Convertible Compartment Temperature

1. Press CONVERTIBLE once to turn on the temperature control.



2. Press CONVERTIBLE repeatedly to cycle through the available temperature settings, from 45°F to -4°F or from 7°C to -20°C.

NOTE: Each press of the button advances the setting by three degrees.

3. Release CONVERTIBLE to select the desired temperature setting.

Freezer Compartment Temperature

1. Press FREEZER once to turn on the temperature control.



2. Press FREEZER repeatedly to cycle through the available temperature settings, from 5°F to -13°F or from -14°C to -24°C.

NOTE: Each press of the button advances the setting by one degree.

3. Release FREEZER to select the desired temperature setting.

Ice Maker Control

- Press and hold FREEZER for 3 seconds to turn On/Off the ice maker.

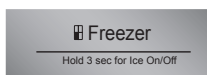

NOTE: When the ice maker is on, the Ice Maker icon  is illuminated.

Additional Features

IMPORTANT: Press and hold UNLOCK for 3 seconds to unlock the control panel.



Press MODE to toggle between the Super Freeze and Energy Saver features.

Super Freeze

The Super Freeze feature rapidly lowers the freezer compartment temperature to freeze fresh food faster and maintain the temperature of the frozen food during periods of high usage, full grocery loads, or temporarily warm room temperatures.

The Super Freeze feature lowers the temperature in the freezer compartment to -13°F (-25°C).

- Press MODE until the Super Freeze icon  appears.



- Press either the MODE or FREEZER control to manually turn off Super Freeze.

NOTE: When Super Freeze is on,  is illuminated and -13°F or -25°C appears in the temperature display.

- Press FREEZER to manually turn off Super Freeze and return to the previously set temperature.

NOTE: Super Freeze will automatically turn off after several hours, and the freezer will revert to its previous temperature setting.

Energy Saver

The Energy Saver feature reduces energy use by raising the Refrigerator Compartment temperature to 43 °F (6 °C) and the Freezer Compartment temperature to 1 °F (-17 °C).

IMPORTANT: The compartment temperatures in Energy Saving mode are not suitable for the storage of certain food items.

- Press MODE until the Energy Saver icon  appears.

NOTE: When the refrigerator is in Energy Saver mode,  is illuminated.

- Press FREEZER or FRIDGE to manually turn off the Energy Saver feature.

Door Leveling and Alignment

Level Refrigerator

The refrigerator must be level to maintain optimal performance and appearance.

1. Turn the leveling feet on the bottom, front of the cabinet to raise or lower that side of the refrigerator until the refrigerator is level side-to-side.
2. Turn both feet, by the same amount, to slightly raise the front of the refrigerator. This will make it easier for the doors to close.

NOTE: Having someone push against the top of the refrigerator takes some weight off the leveling feet. This makes it easier to turn the feet.

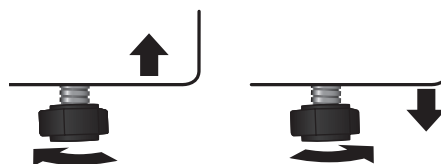

Align Doors

If the edges of the refrigerator doors do not align with each other, you can make adjustments.

Using Adjustable Foot

- Turn the adjustable foot to raise or lower that side of the refrigerator.
 - Clockwise - to raise
 - Counterclockwise - to lower

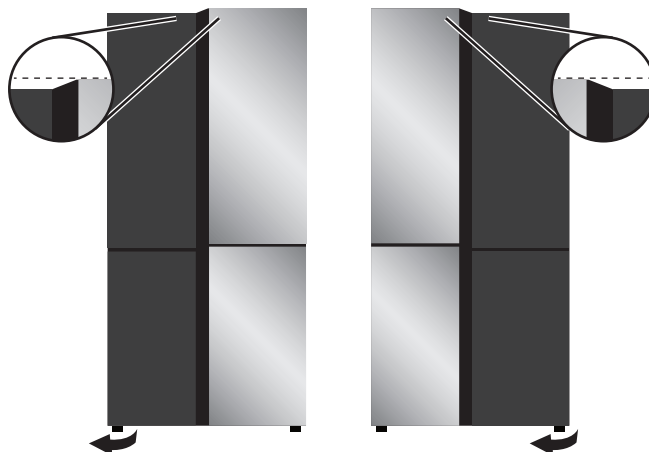

Defrost Mode

Automatic Defrost

When the accumulated running time of the compressor reaches the set point (dependent on the environmental temperature) the compressor will automatically enter defrost mode.

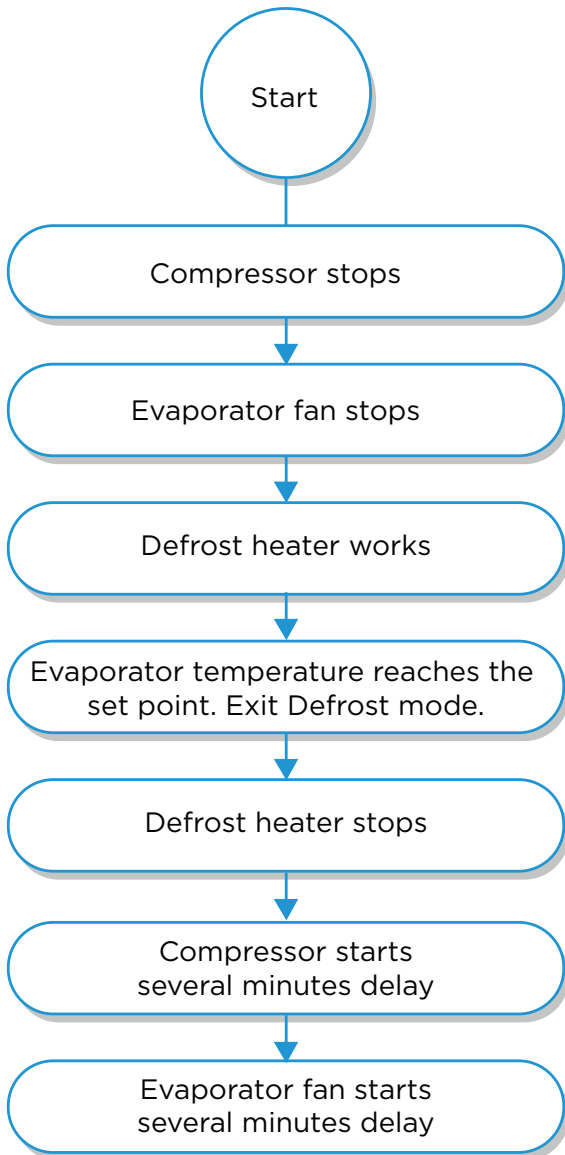

Forced Defrost

IMPORTANT: Forced Defrost must be initiated within 10 minutes of the refrigerator being powered on.

1. Unplug power supply cord, and then plug it back into the electrical outlet.
2. Unlock the control panel.
3. Press and hold the FRIDGE and CONVERTIBLE controls at the same time for 5 seconds.
4. The refrigerator enters Forced Defrost mode.

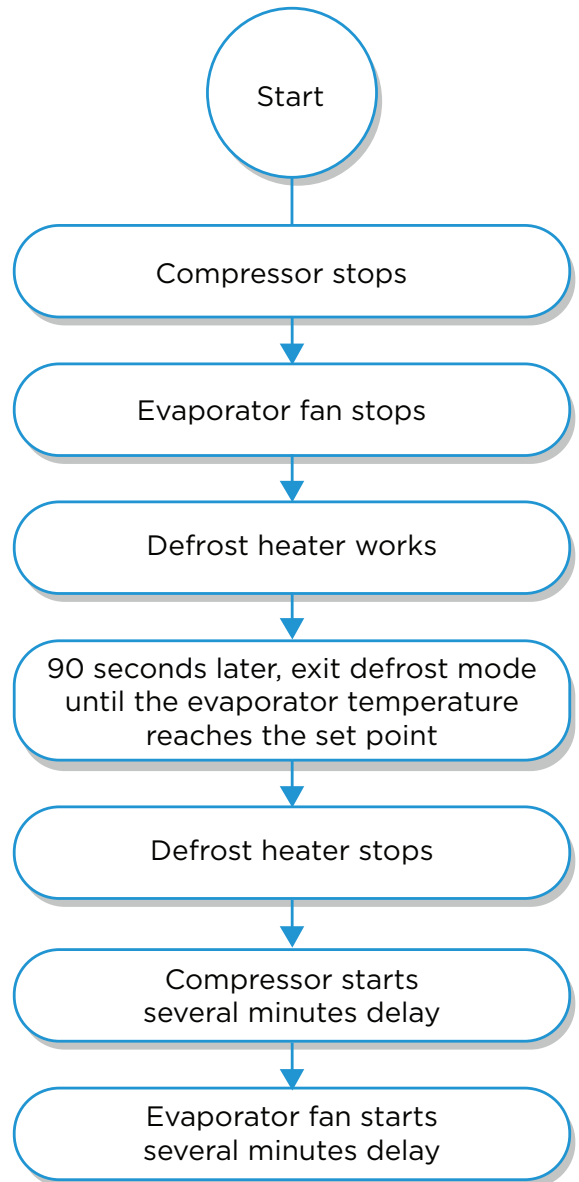

5. Troubleshooting Charts

Error Code Summary

CODE	DISPLAY AREA	PROBLEM
E0	Refrigerator temperature display area	Environment sensor malfunctions
E1	Refrigerator temperature display area	Refrigerator sensor malfunctions
E3	Freezer temperature display area	Freezer sensor malfunctions
E5	Convertible temperature display area	Convertible sensor malfunctions
E2	Refrigerator temperature display area	Refrigerator defrost sensor malfunctions
E4	Freezer temperature display area	Freezer defrost sensor malfunctions
E6	Convertible temperature display area	Convertible defrost sensor malfunctions
E8	Refrigerator temperature display area	Humidity sensor malfunctions
E9	Freezer temperature display area	Ice maker sensor malfunctions
Eb	Freezer temperature display area	Ice maker malfunctions
Ec	Refrigerator temperature display area	Communication sending malfunctions
EF	Freezer temperature display area	Ice maker ice turning malfunctions
EL	Freezer temperature display area	Flow meter malfunctions
EP	Refrigerator temperature display area	Water injection malfunction
Er	Refrigerator temperature display area	Communication receiving malfunctions
F1	Freezer temperature display area	Freezer fan malfunctions
F2	Refrigerator temperature display area	Refrigerator fan malfunctions
F3	Convertible temperature display area	Convertible fan malfunctions

NOTE: Fault codes will show for the first four minutes after the refrigerator is plugged in. Codes will appear in the display area specific to the section where the error occurred.

Humidity Sensor Error

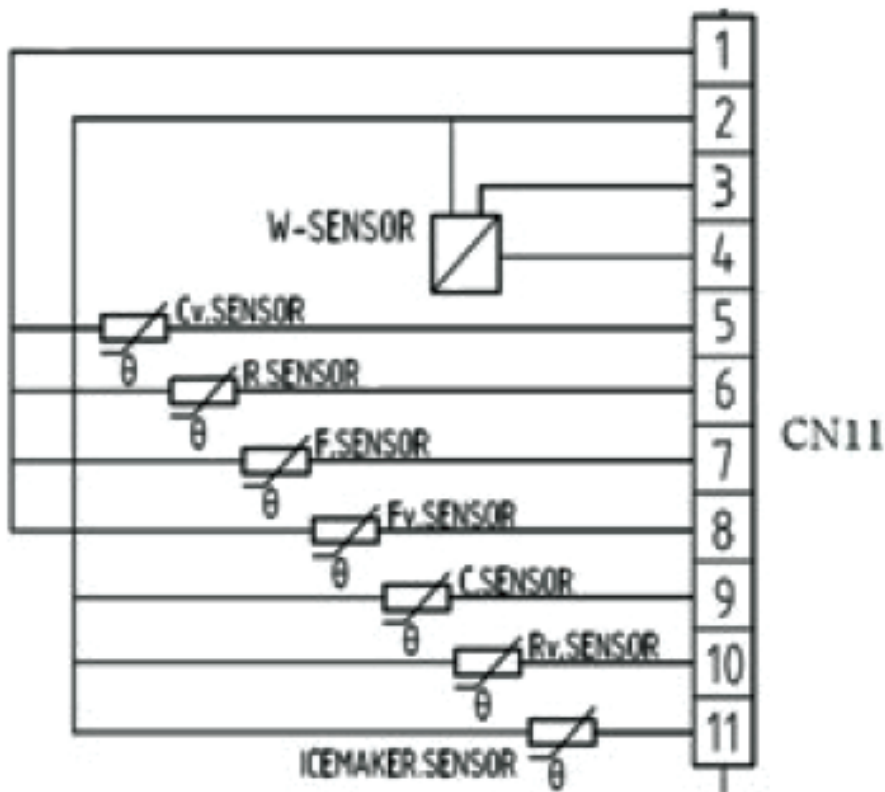
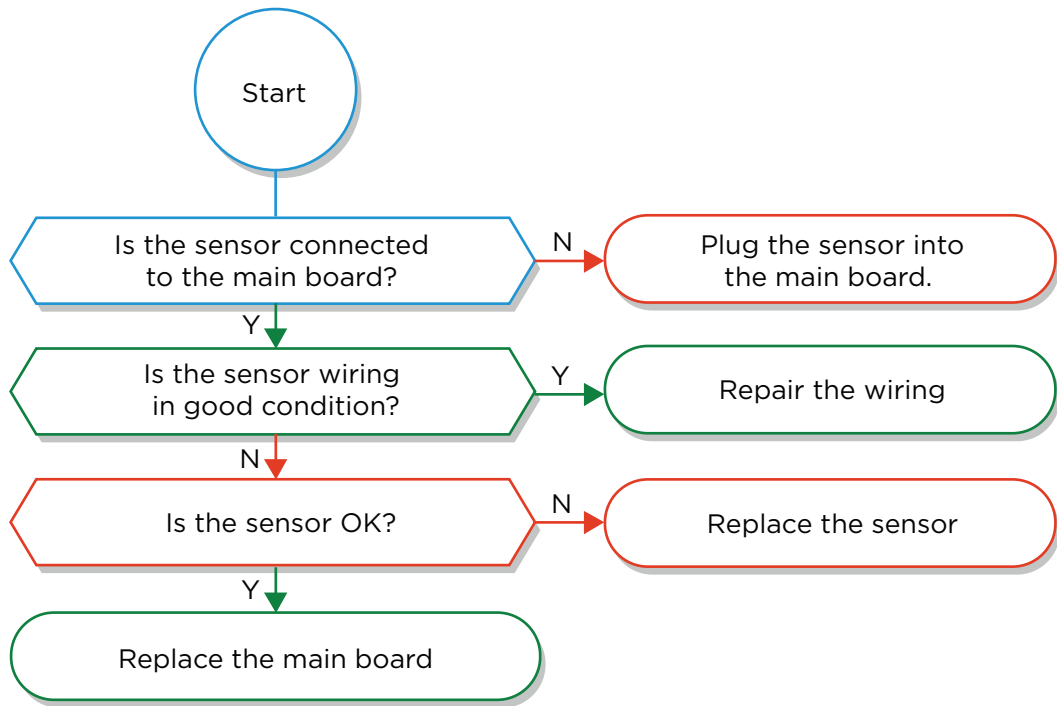

NOTE: The humidity sensor corresponds to pins No. 2, No. 3 and No. 4 on the CN11 connector of the main board. Pin No. 2 is the ground pin.

1. Check the voltage across Pins No. 2 and No. 3 (5 volts DC) and across Pins No. 2 and No. 4 (1.2 to 3.5 volts DC). If the result is abnormal, the humidity sensor is faulty.
2. Replace the humidity sensor.

Normal Voltage Measurement:

- Pins No. 2 and No. 3 is 5V
- Pin No. 4 is between 1.2V and 3.5V (the voltage will vary depending on ambient temperature and humidity).

Other Sensor Errors

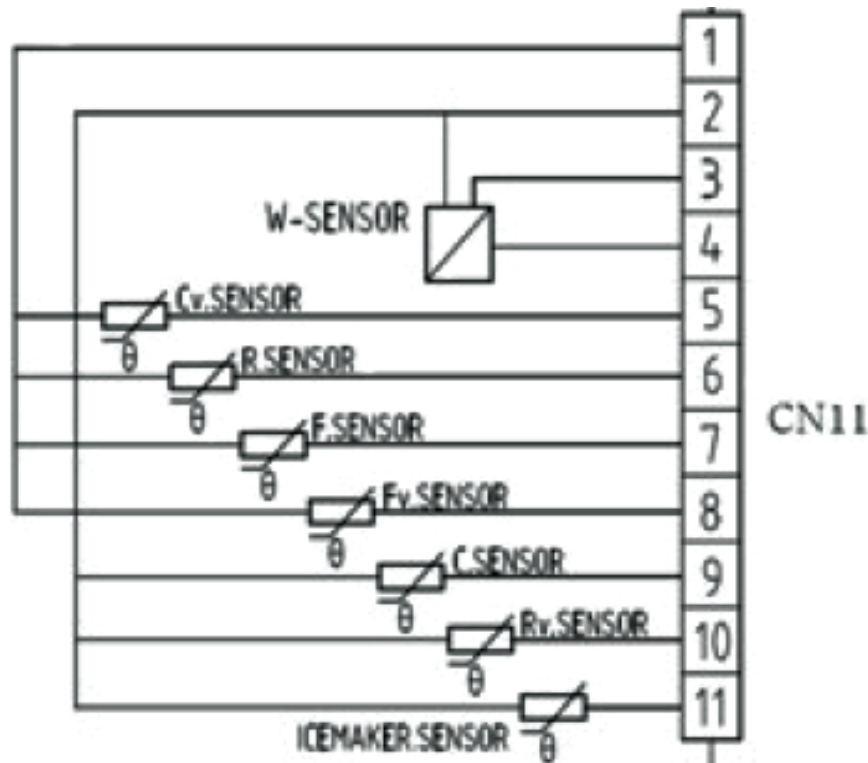
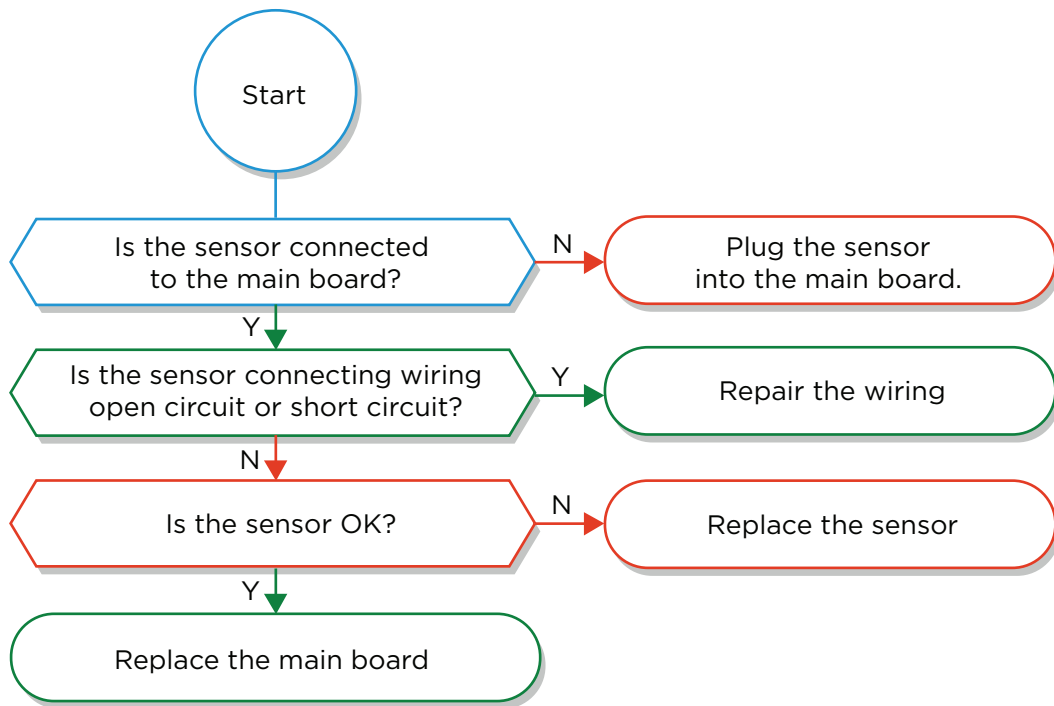

1. Use a multimeter to measure the resistance of the sensor. If the circuit is open or there is a short circuit, the sensor is faulty.
2. Replace the faulty sensor.

Sensors correspond with pins on the CN11 connector of the main board:

Ground Pins: Pins No. 1 and No. 2

Refrigerator Compartment sensor: Pins No. 1 and No. 6

Freezer Compartment sensor: Pins No. 1 and No. 7

Refrigerator Defrost sensor: Pins No. 2 and No. 10

Freezer Defrost sensor: Pins No. 1 and No. 8

Convertible Compartment sensor: Pins No. 2, No. 9

Convertible Defrost sensor: Pins No. 1, No. 5

Ice Maker sensor: Pins No. 2, No. 11

Communication Error

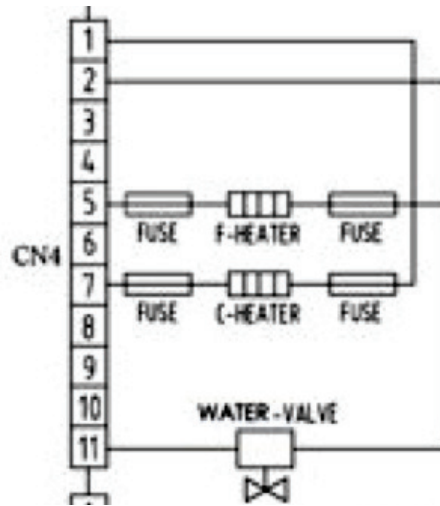
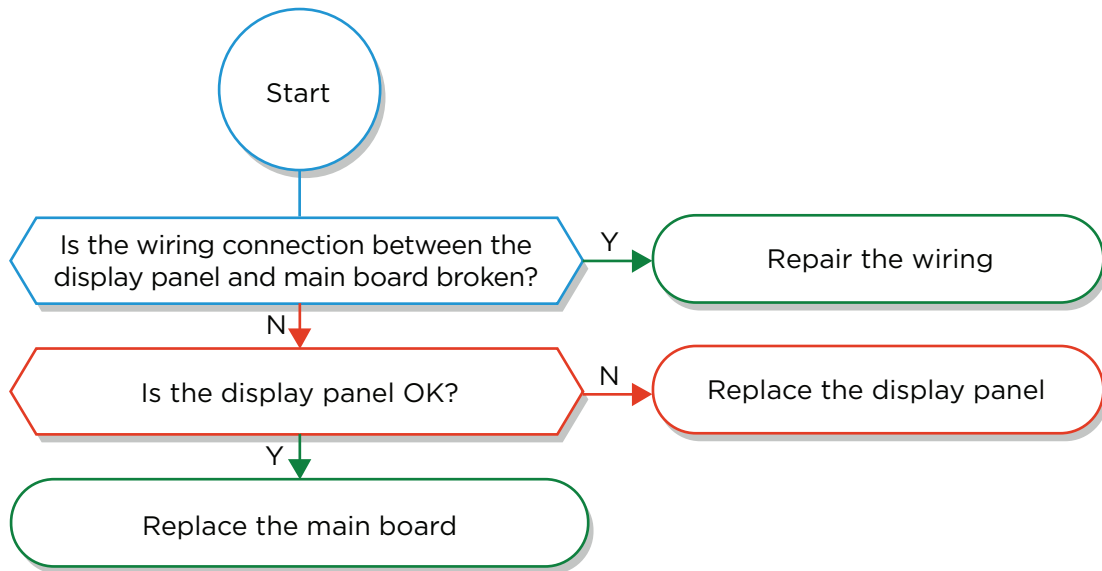

NOTE: The Communication sensor corresponds to pins No. 1-4 on the CN8 connector of the main board.

Basic Troubleshooting

Refrigerator is Not Operating

PROBLEM	POSSIBLE CAUSE(S)	SOLUTION
Refrigerator does not run	Refrigerator is unplugged.	Plug refrigerator into a grounded 3 prong outlet.
	Breaker is tripped or turned off, or fuse is blown.	Reset/Turn on breaker or replace fuse.
	Refrigerator is in defrost mode.	Wait for defrost cycle to end and cooling system to restart.
Refrigerator compressor runs frequently or for long periods of time NOTE: This refrigerator is designed to run for longer periods of time at a lower energy usage.	Refrigerator is first plugged in.	This is normal. Allow 24 hours for the refrigerator to cool down.
	Warm or large amounts of food added.	This is normal.
	Door is left open, or refrigerator is not level.	Check that an item is not preventing door from closing. Level the refrigerator. See "Level Refrigerator."
	Hot weather or frequent openings	This is normal.
	Temperature control set to coldest setting.	Adjust temperature to a warmer setting.

PROBLEM	POSSIBLE CAUSE(S)	SOLUTION
Refrigerator has an odor	Food is not sealed or packaged properly.	Reseal packaging. Place an opened box of baking soda in the refrigerator, replace every 3 months.
	Interior needs to be cleaned.	Clean the interior. See "Cleaning."
	Food stored too long.	Dispose of spoiled food.
Light does not come on	Refrigerator is unplugged.	Plug refrigerator into a grounded 3 prong outlet.
	LED light is burned out.	Check wiring and replace light as needed.
	Faulty door switch.	Check the door switch to see if it is functioning properly. Replace if needed.
Doors do not close easily	Refrigerator is not level.	See "Level Refrigerator."
	Something is obstructing door closure.	Check for and remove obstructions.
	The back of the refrigerator is not tilted downward.	Raise the front leveling legs slightly ($\frac{3}{8}$ "- $\frac{1}{2}$ ") so that the doors can self close.
Vibration or rattling	Refrigerator is not resting firmly on floor.	See "Level Refrigerator."
Normal Sounds	It sounds like water is flowing from the refrigerator.	Refrigerant flowing in the lines will make this sound when the compressor starts and stops.
		The refrigerator has an automatic defrosting system. The defrosted water will make this sound.
	Humming or buzzing sounds	The compressor and fans used for cold air circulation can make this sound. If the refrigerator is not level, the sound will be louder.
	Cracking or clicking sounds	The interior parts will make this sound as they contract and expand in response to temperature changes.
	Popping noise	May occur during automatic defrosting.

Temperature and Moisture

PROBLEM	POSSIBLE CAUSE(S)	SOLUTION
Refrigerator or freezer is too warm	Temperature control is not set cold enough.	Adjust the compartment to a colder setting; allow 24 hours for the temperature to adjust.
	Doors opened frequently or left open.	Limit door openings to maintain the internal temperature. Check that an item is not preventing door from closing.
	Warm food added recently.	Allow time for food and refrigerator to cool.
	The space between the back of the refrigerator and the wall is too close.	Allow 2" (5 cm) space between the back of the refrigerator and the wall.
	Items against back of compartments are blocking proper airflow.	Store items only inside the trim of the glass shelves; don't place items against sides of the compartments or directly in front of any vents.
Refrigerator or freezer is too cold	Temperature control is set too cold.	Adjust temperature in the compartment to the next warmer setting; allow 24 hours for temperature to adjust.
Moisture on exterior/ interior of refrigerator	High humidity	This is normal during times of high humidity. Dry surface and adjust temperature to a slightly colder setting.
	Doors opened frequently or left open.	Keep door closed. Check that an item is not preventing the door from closing. Level the refrigerator. See "Level Refrigerator."
	Open container of water in refrigerator	Cover or seal container

PROBLEM	POSSIBLE CAUSE(S)	SOLUTION
Frost or ice crystals on frozen food	Freezer door left open or opened frequently.	Limit door openings to maintain the internal temperature. Check that an item is not preventing door from closing.
	Refrigerator door is not closing completely or the door gasket is not sealing.	Level the refrigerator. See "Level Refrigerator." Confirm condition of door gasket, and replace if necessary.
	Items blocking freezer air vents and preventing proper air flow.	Move items away from rear wall.
Food freezing in refrigerator	Food placed too close to the air vent.	Move items away from back and top of the refrigerator.
	Temperature control set too cold.	Adjust the temperature to a less cold setting.

Ice

PROBLEM	POSSIBLE CAUSE(S)	SOLUTION
The ice maker is not producing ice, enough ice, or cubes are hollow.	Ice maker is not turned on	Press and hold FREEZER for 3 seconds to turn On/Off the ice maker. See "Using the Controls."
	New installation	Wait 24 hours after installation for ice production to begin.
	Kink in the water line	Replace water line.
	Inadequate water pressure	Contact a licensed, qualified plumber.

Start Fault

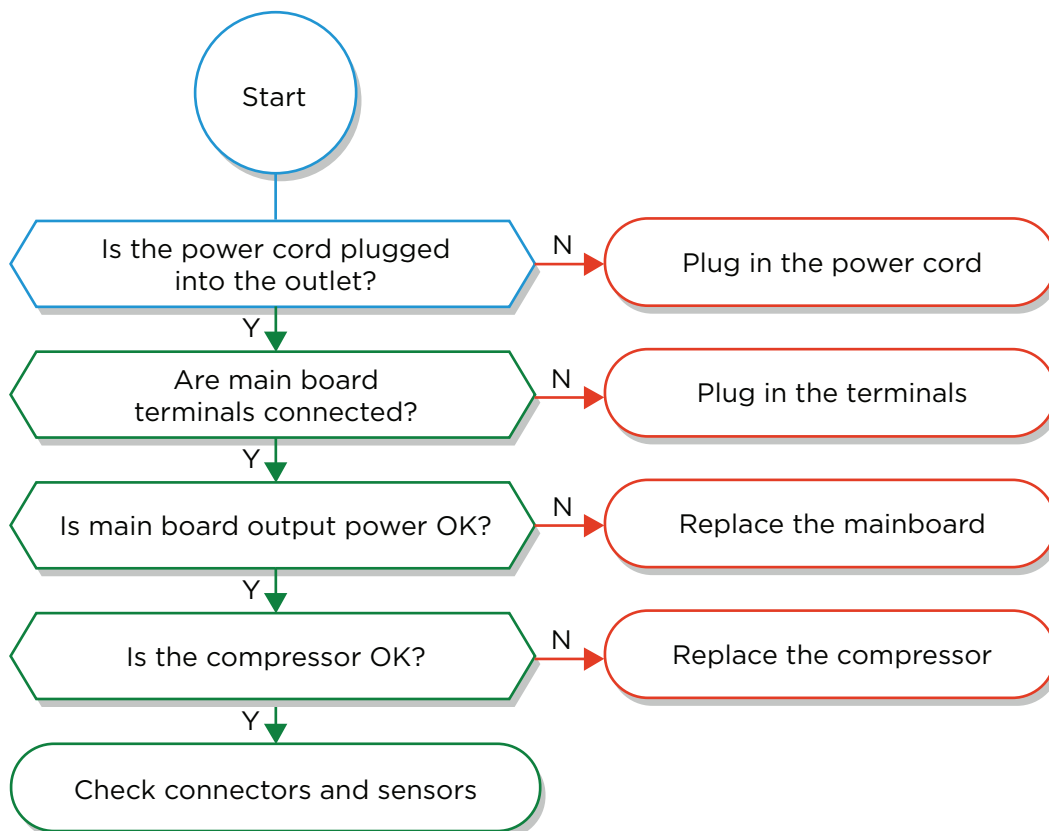

Freezer Compartment Temperature

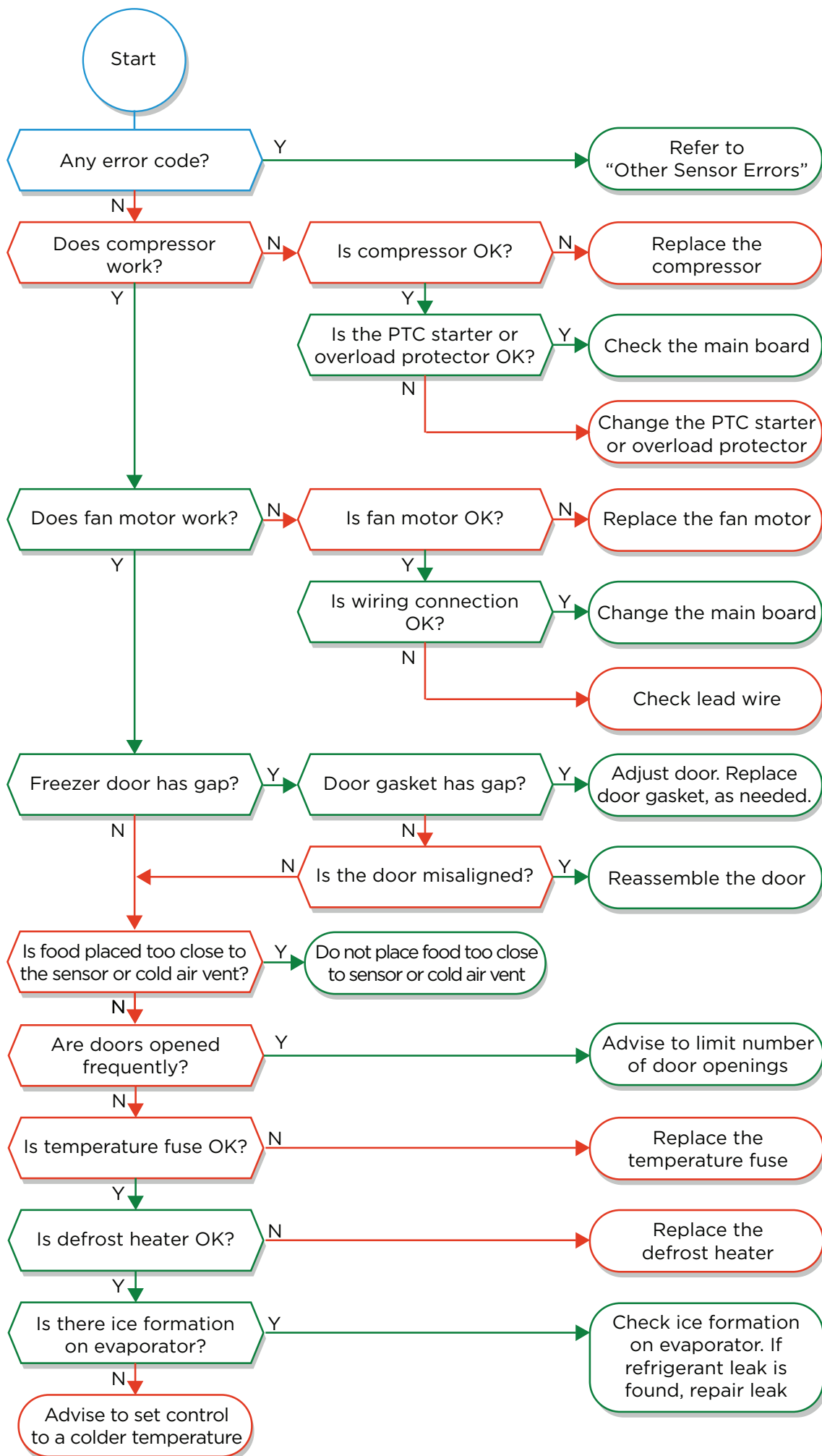

Refrigerator Compartment Temperature

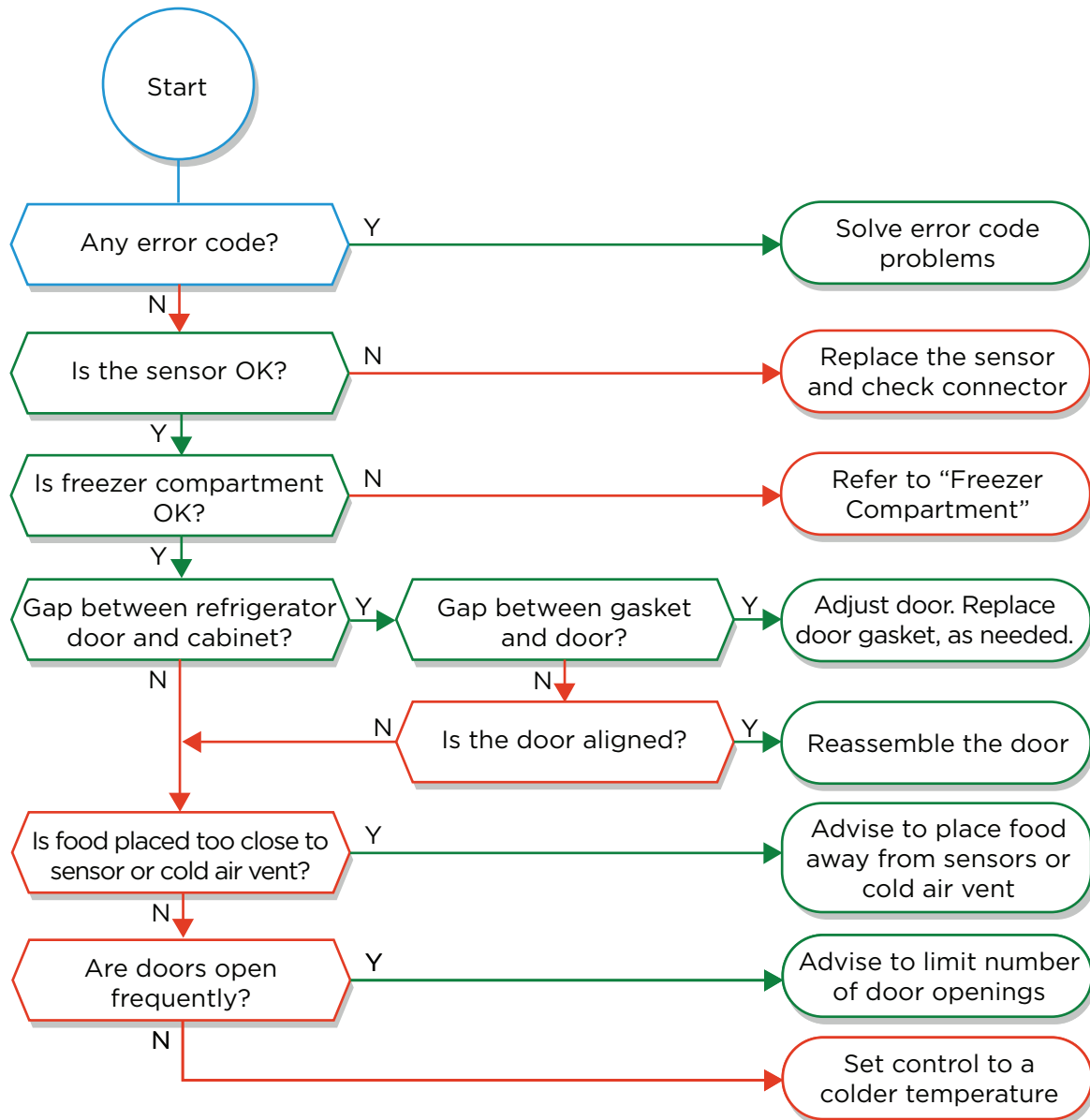

Thick Frost in Freezer Compartment

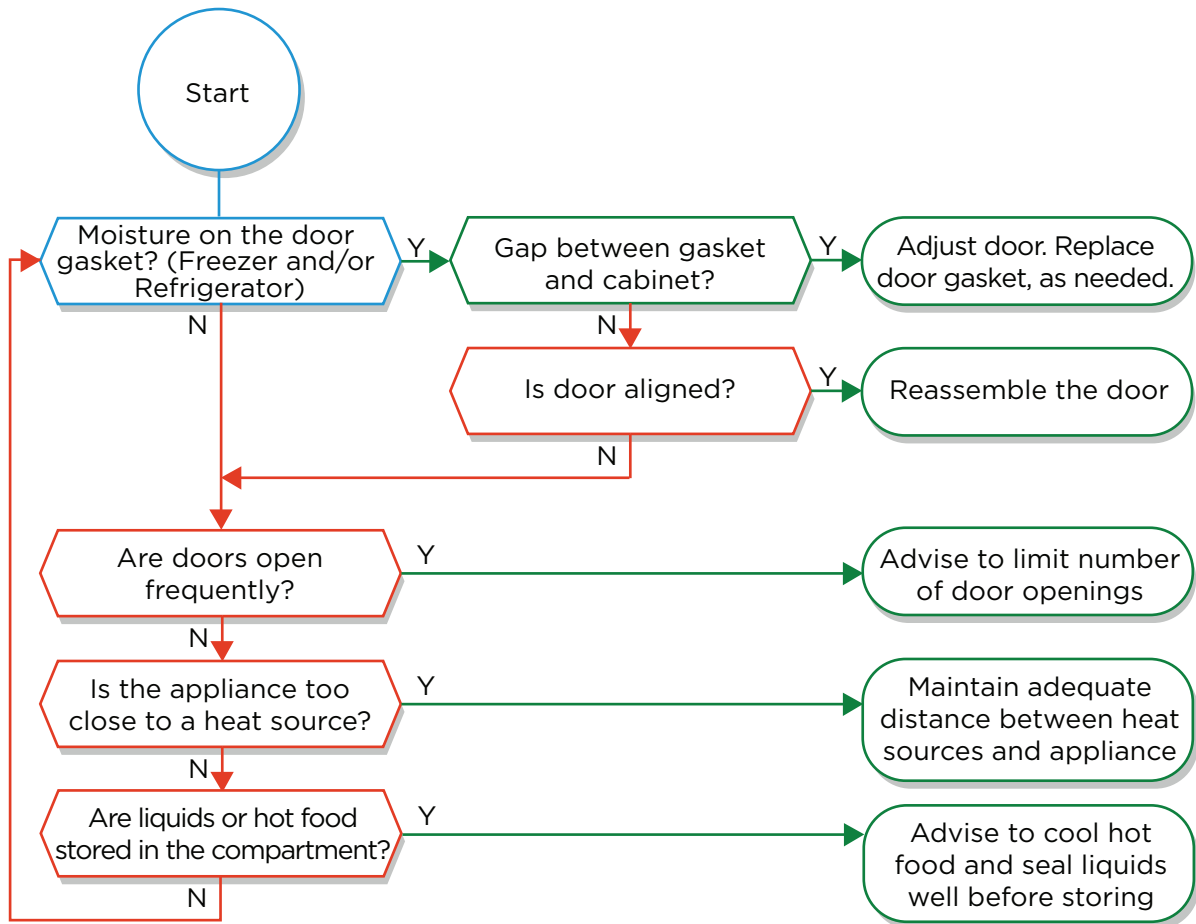

Moisture in Refrigerator Compartment

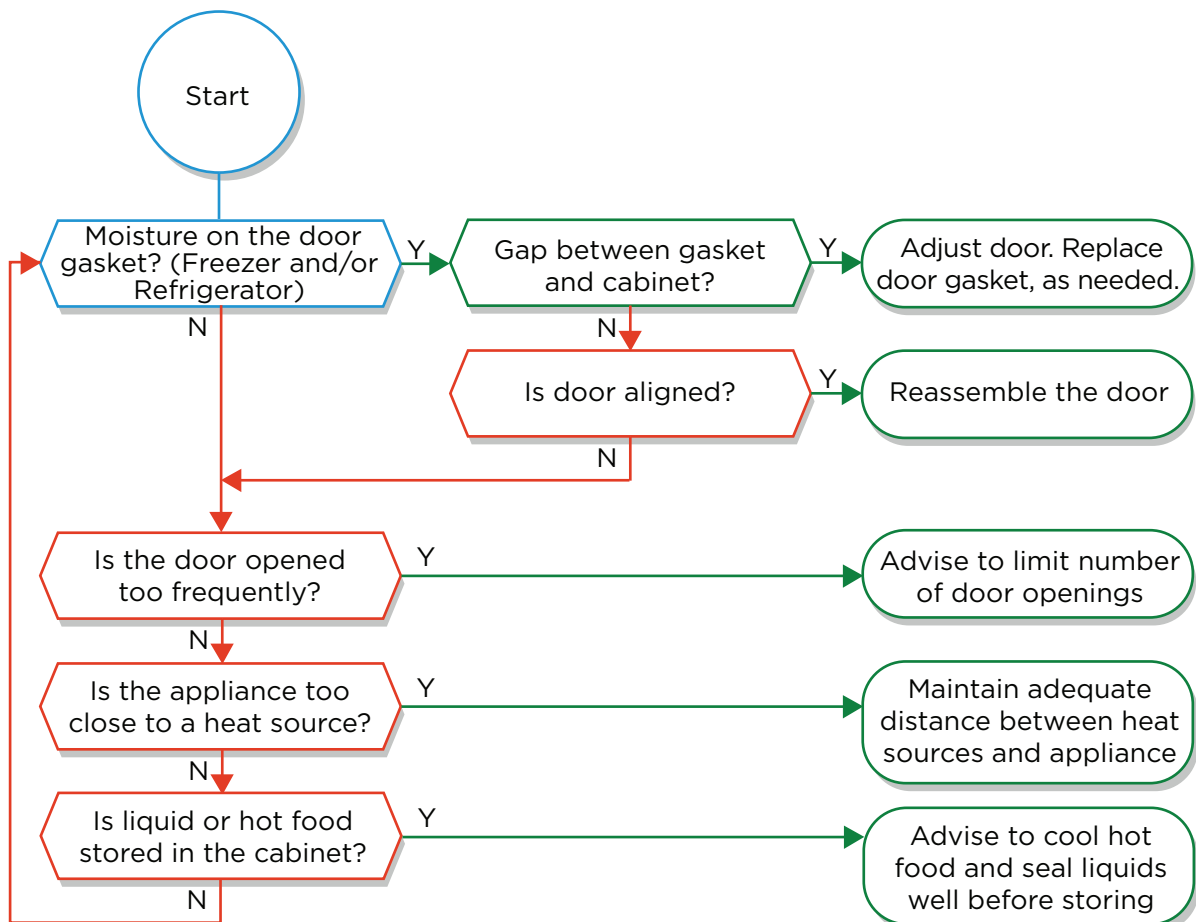

Crisper Temperature

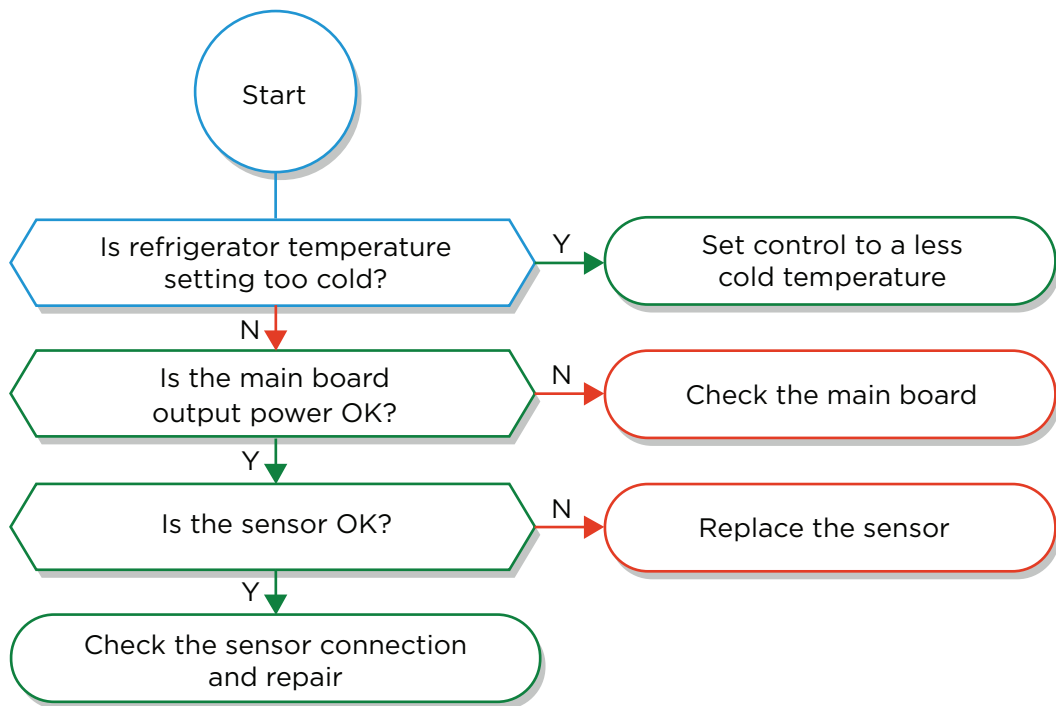

Light Function

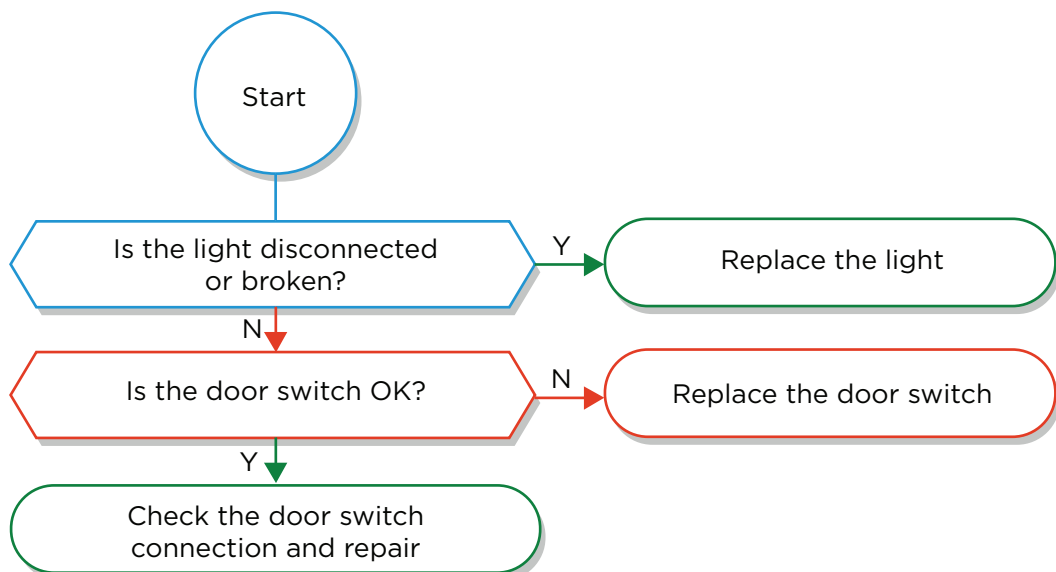

Noise

Compressor Noise

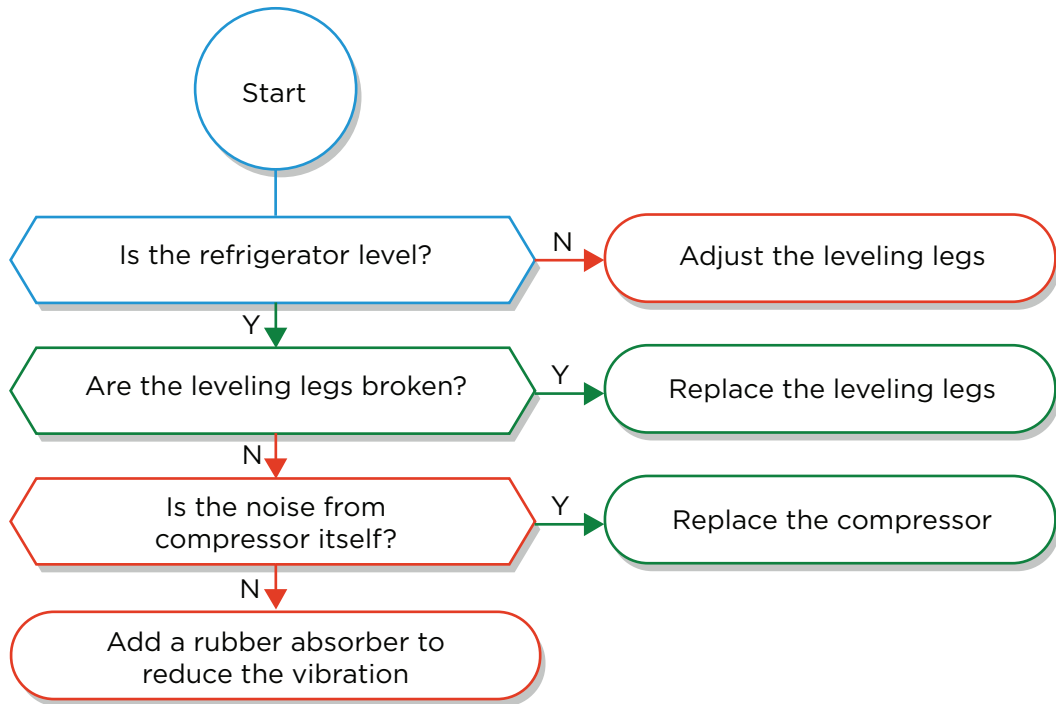

Refrigerant Flowing Noise

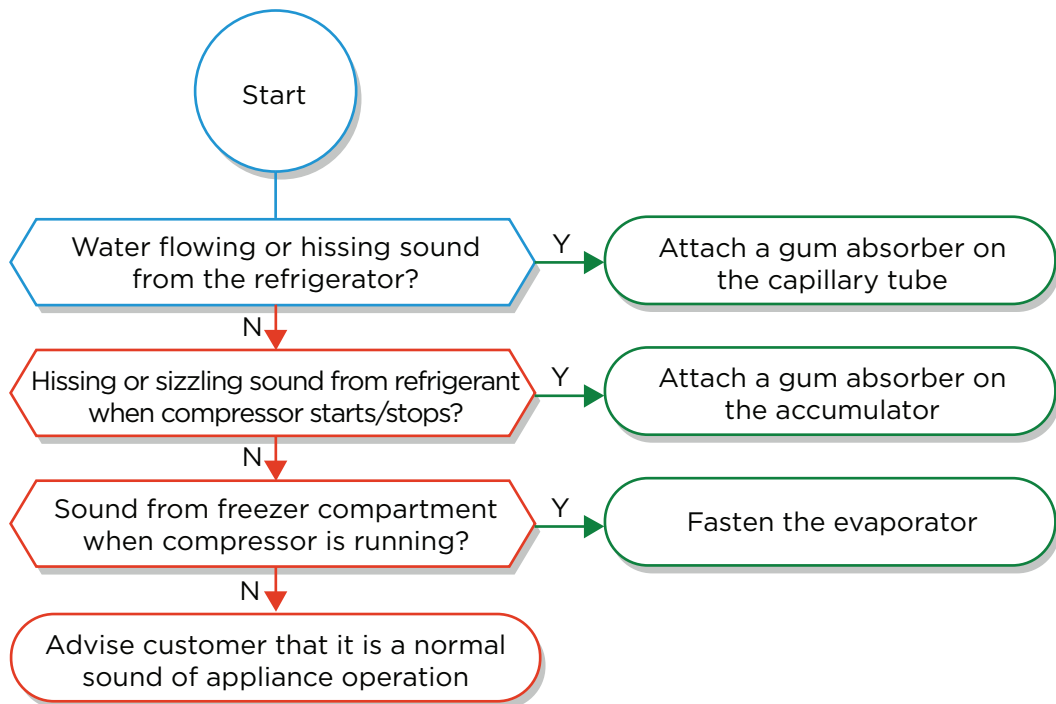

Fan Motor Noise

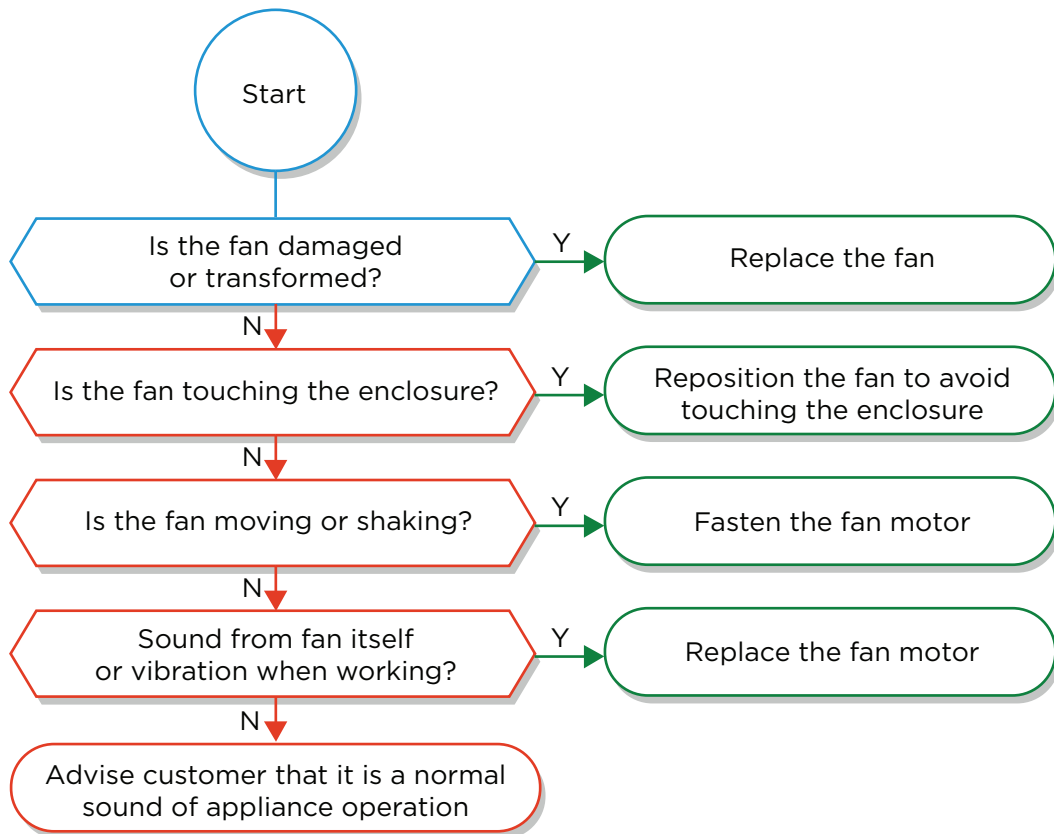

Pipe Noise

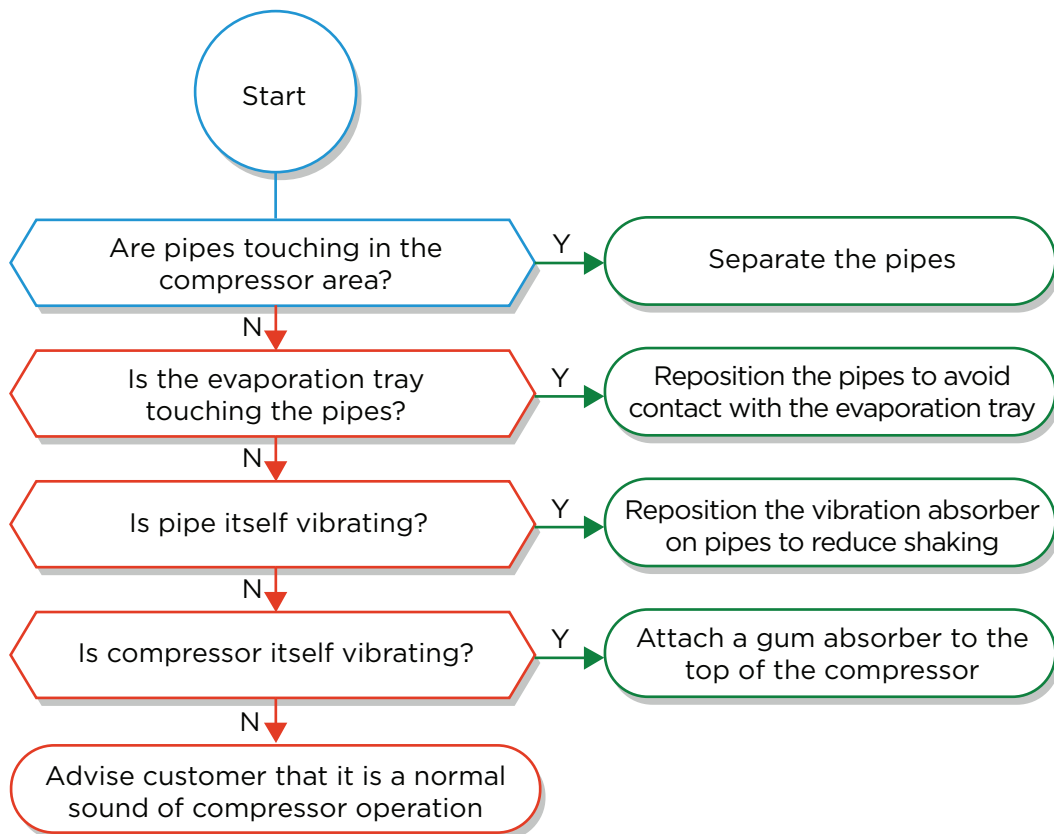

6. Wiring Diagram

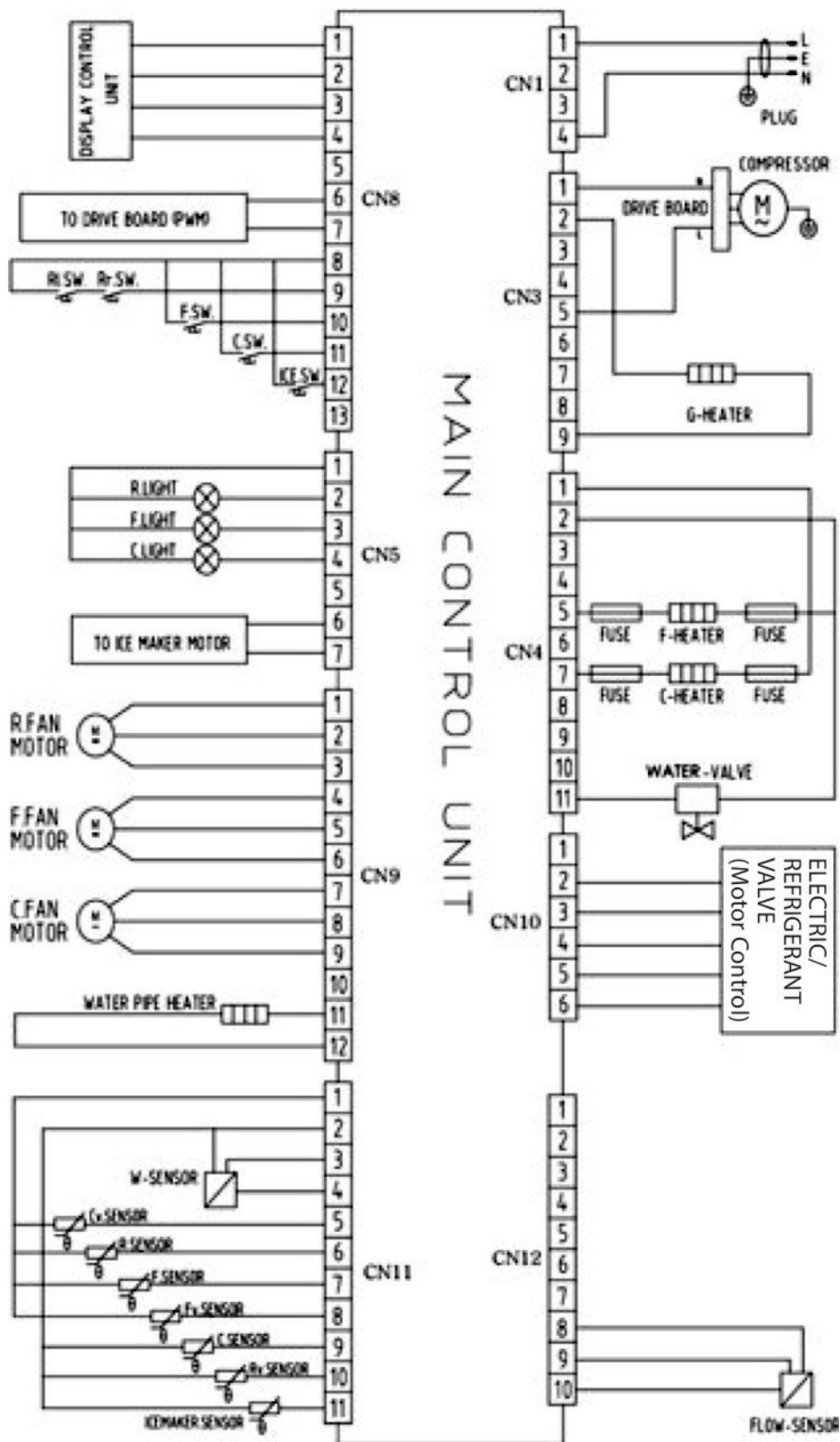

7. Component Testing and Disassembly

Main Board

Check the Main Board

IMPORTANT: If the problem is most likely caused by a faulty main board, replace the main board first to confirm.

NOTE: Replacement board settings are at factory default. After replacing the main board, set all temperatures to the customer's previous setting.

Remove the Main Board

1. Unplug the refrigerator or disconnect power.
2. Using a Phillips screwdriver, remove the screws fastening the electrical compartment cover to the cabinet.
3. Remove the compartment cover.



4. Unplug the terminals on the main board, as shown.

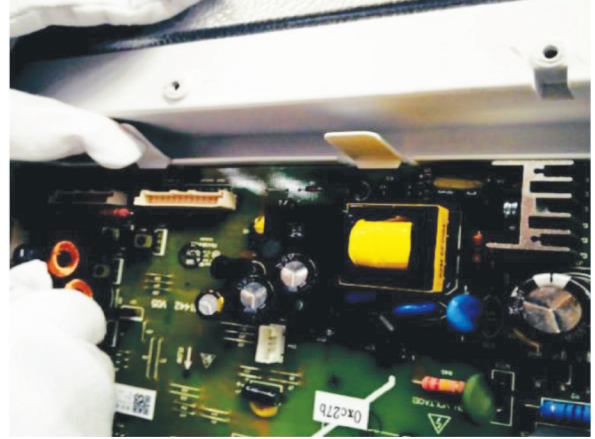

5. Using your fingers, press upward on the release tabs, and then pry the main board away from its compartment.

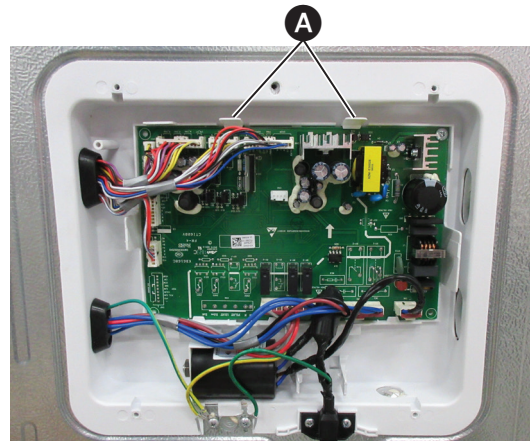

A Release Tabs

Compressor

Input Voltage: 115V

Input Frequency: 60Hz

The compressor takes low temperature and low pressure gas from the evaporator and compresses this gas to form high-temperature and high-pressure gas. It then delivers the gas to the condenser.

Check the Compressor

After the refrigerator is powered on, the compressor should start within 1 minute.

If the compressor does not start, remove the electrical compartment cover to check the main board.

Main Board Wiring Connection

Check the wiring connection between the compressor and the main board. If the connection is loose, repair the connection.

Main Board Voltage and Frequency

- Use a multimeter to measure the voltage between Label N and Label COMP on the CN3 connector of the main board.
- Use a multimeter to measure the frequency between Pins No. 6 and No. 7 on CN8 connector of the main board.

If the measured voltage is equal to the power supply output, the compressor is faulty.

OR

If the voltage is NOT equal to power supply output and/or the output frequency is NOT stable, the main board is faulty. Replace the main board. For instructions, see “Main Board.”

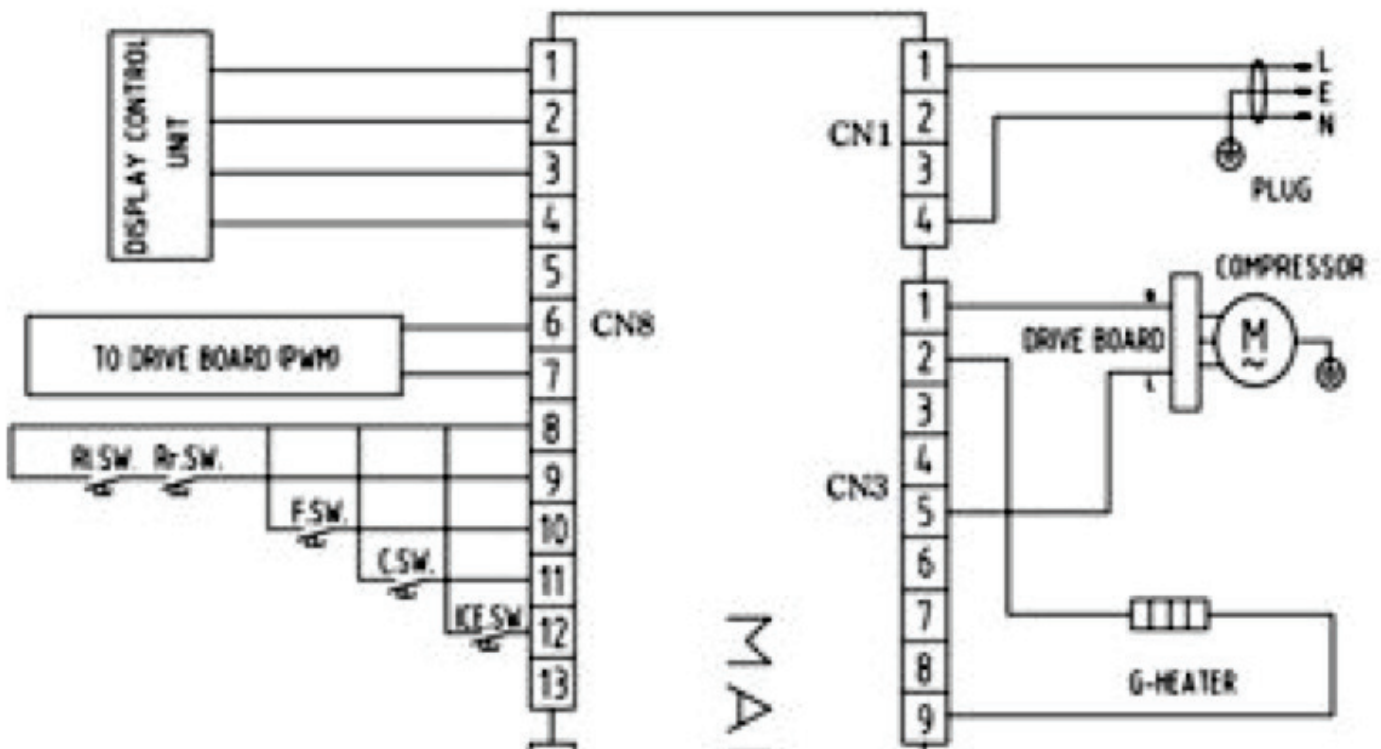

PTC Starter and OverLoad Protector (OLP)

The compressor has Overload Protection. The Positive Temperature Coefficient (PTC) starter and the Overload Protector (OLP) are attached to the sealed compressor.

The PTC starter relay starts the compressor.

If the exterior of the PTC is damaged, the resistance value may be altered. The altered resistance can damage the compressor and result in a no-start or hard-to-start condition.

Remove the PTC Starter and Overload Protector

1. Unplug the refrigerator or disconnect power.
2. Using a screwdriver, pry up the jump ring on the protector cover.
3. Using a screwdriver, remove the protector cover.
4. Grasp the Overload Protector, and then pull it out.
5. Grasp the PTC starter, and then pull it out.



A **B** **C**

- A** PTC Starter
- B** Screw
- C** PTC Cover

Fan Motor

Rated Voltage: 6-15V

Rated Input Power: 2.5W

Check the Fan Motor

Main Board Wiring Connection

Make sure the wiring connection between the fan motor and main board is secure. If the wiring connection is loose, repair the connection.

The fan motor corresponds to pins no. 1-9 on the CN9 connector of the main board.

- Pins No. 2, No. 5 and No. 8 connect 12V power.
- Pin No. 9 connects the Ground.

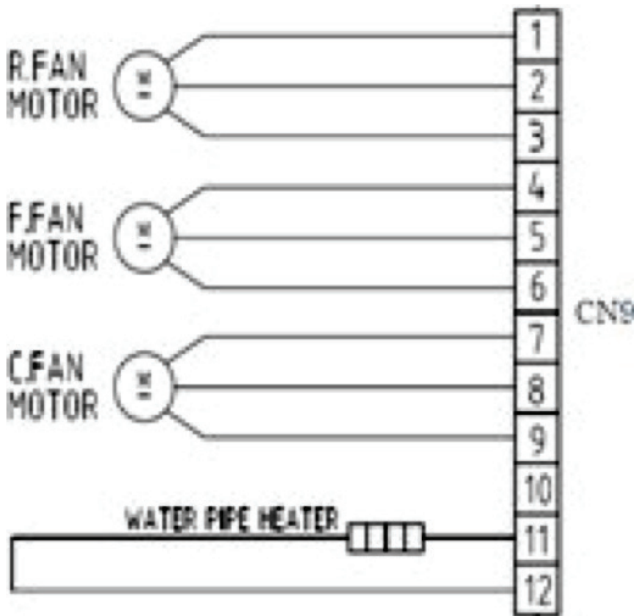

If the fan motor works normally, replace the main board.

If the fan motor does not work normally, replace the fan motor.

Remove the Freezer and Convertible Fan Motors

1. Unplug the refrigerator, or disconnect power.
2. Using a screwdriver, remove the screw fastening the clapboard beam to the cabinet.



3. Using your fingers, pry up the clapboard beam to remove, as shown.



4. Remove the freezer/convertible divider.

WARNING:

The red loop behind the mullion is a hot gas loop.

- Do NOT bend red loop.
- Do NOT put clapboard screw into loop.



5. Using a screwdriver, pry up the rear clapboard part at the clips, and then push the divider to the right and remove.



6. Pull the freezer air flow channel component from its compartment, as shown.



7. Unplug the air flow channel terminals.



8. Separate the air flow channel cover from the foam.

9. Locate the screws under the tape, and then remove the screws securing the fan.

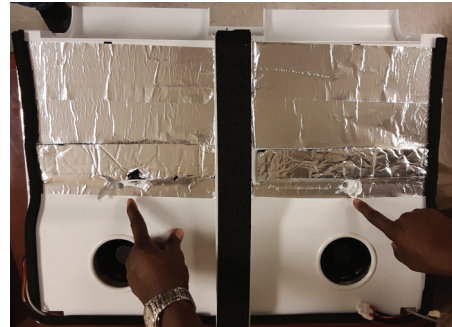

10. Remove the fan.



Refrigerator Air Channel

Remove the Air Flow Channel



1. Pry off label, and then remove the center screw. Gently pull the back panel toward you to remove air flow channel.



Fan Motor Replacement



Refrigerator Temperature Sensor Replacement



Light

Rated Voltage: DC12V

Rated Power:

Light	Rated Power (W)
Refrigerator	3
Freezer	1
Variable temperature	1

Check the Light

Main Board Wiring Connection

1. Make sure the wiring connections between the light and main board are secure. If wiring connection is loose, repair connection.

Refrigerator Light 1: Corresponds to Pins No. 8 and No. 9 on CN6 connector on the main board.

Freezer Light: Corresponds to Pins No. 6 and No. 9 on CN5 connector on the main board.

Convertible Light: Corresponds to Pins No. 7 and No. 9 on CN5 connector on the main board.

Check Output Voltage

Using a multimeter, check the voltage output of the pins on the main board that correspond with the non-working light.

If the voltage measures 12V, the main board is good. Replace the light.

OR

If the voltage does not measure 12V, replace the main board.

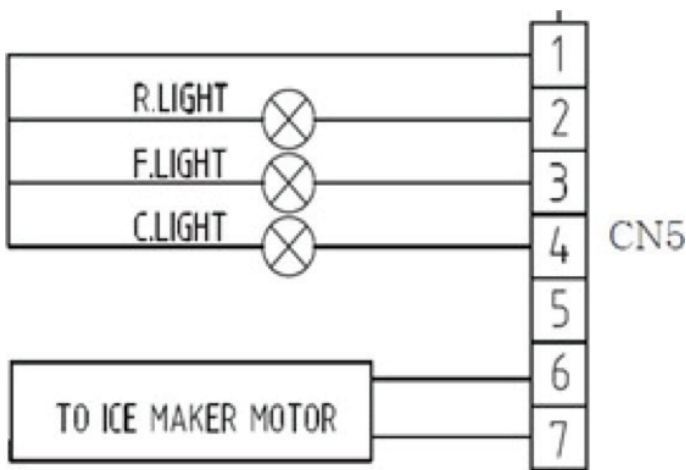

Remove the Refrigerator Light

1. Unplug the refrigerator or disconnect power.
2. Using a flat-blade screwdriver or putty knife, pry up on the light cover to release it from the clips.



NOTE: Locking tabs are at the front and locator tabs are at the rear.



3. Using a flat-blade screwdriver or putty knife, pry up on the light to release it from the clips.



Remove the Freezer/Convertible Lights

To service, see “Remove the Refrigerator Light.”

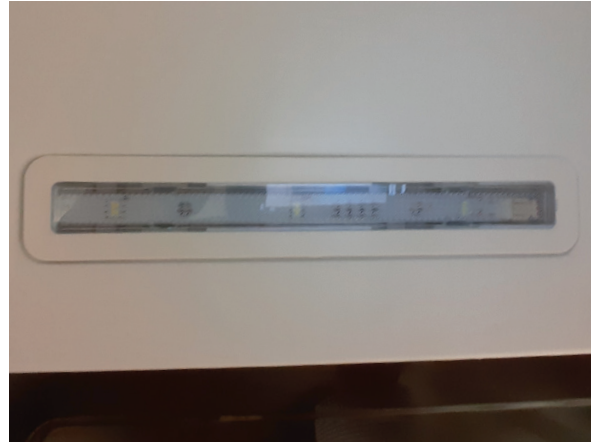
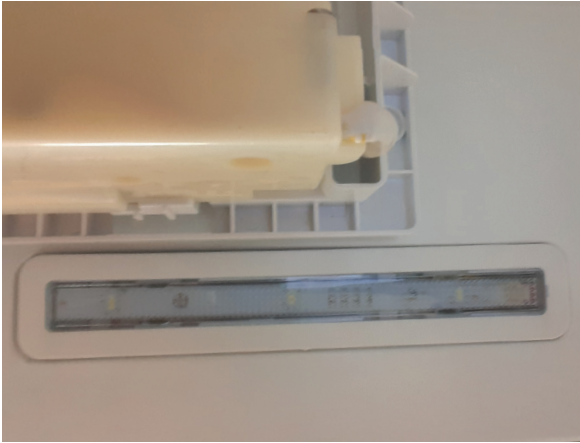

Door Switch

Input Voltage: DC24V

Rated Current: DC0.05A

Check the Door Switch

Main Board Wiring Connection

Make sure the wiring connections are secure. If connection is loose, repair connection.

Refrigerator Door Switch: Corresponds to Pins No. 8 and No. 9 on CN8 connector on the main board.

Freezer Door Switch: Corresponds to Pins No. 8 and No. 10 on CN8 connector on the main board.

Convertible Door Switch: Corresponds to Pins No. 8 and No. 11 on CN8 connector on the main board.

Circuit

If either of the following two tests are abnormal, replace the door switch.

If both of the following tests are normal, replace the main board.

- When the door is closed, the two Door Switch Pins should be a short circuit.
- When the door is open, the two Door Switch Pins should be an open circuit.

Magnet

With the left-hand refrigerator door closed and the right-hand refrigerator door open, place the magnet on the left-hand, front edge of the right-hand, upper door hinge cover.

NOTE: When the magnet is positioned correctly, the refrigerator light will turn off.



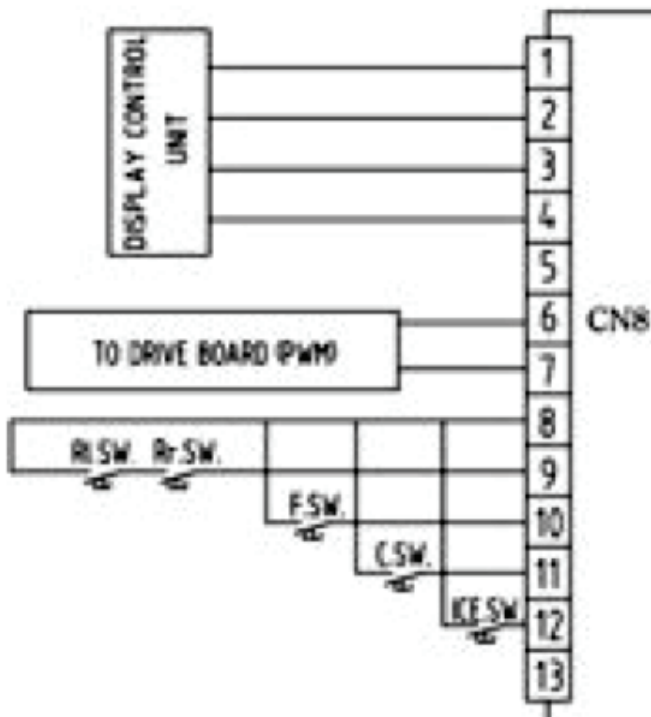

Freezer/Convertible Temperature Fuse and Defrost Heater

Check the Temperature Fuse

Max fusing-off temperature: 72°C

Load Voltage: AC250V

Load Current: 10A

1. Using a multimeter, measure the resistance between the two terminals of the temperature fuse.
2. If it measures an open circuit, replace the corresponding defrost heater fuse (integrated fuses).

Check the Defrost Heater

Rated Voltage: 115V

Rated Power: 130W

1. Enter Forced Defrost mode. See “Defrost Mode.”
2. Use a multimeter to measure voltage between Label N and Label DEF HT on CN4 connector of the main board.
3. If the voltage does not equal the Power Supply Output, the main board is faulty.
4. Replace the mainboard.

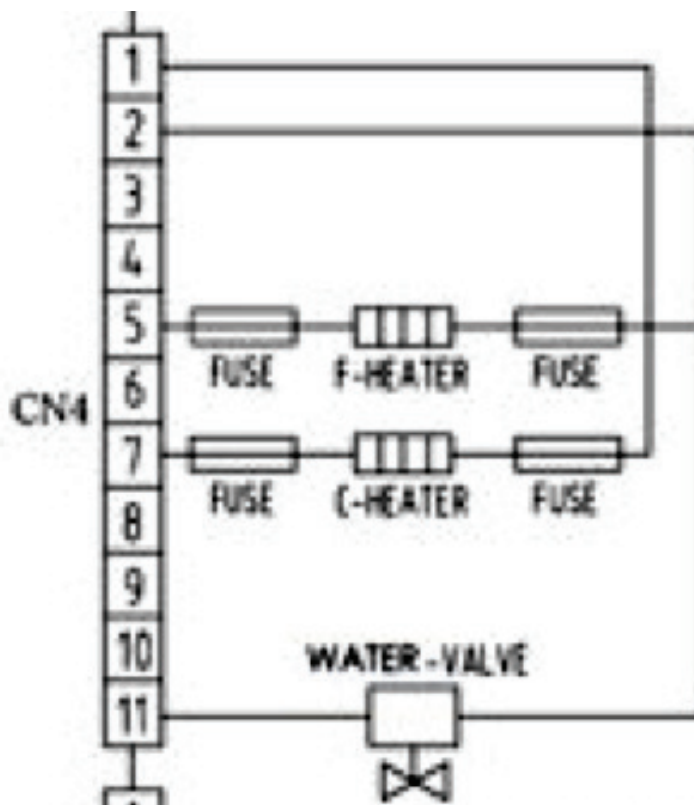

Remove the Defrost Heater and Temperature Fuse

Defrost heater, defrost temp sensors and temp sensor come as an assembly.

1. Remove the Air Flow Channel. See, "Remove the Fan Motor."
2. Unplug the Defrost Heater.

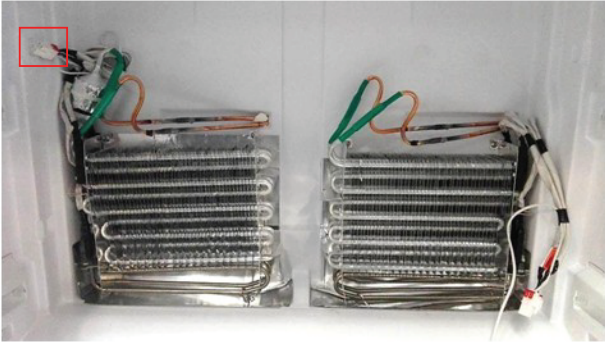

3. Pry up the clips fastening the heater, and then remove the heater.

Ice Maker and Water Pipe

Remove the Water Pipe

1. Working from the back of the refrigerator, use a Phillips screwdriver to remove the screw fastening the ice maker inlet cover to the cabinet.



2. Pull downward on the inlet cover to remove.

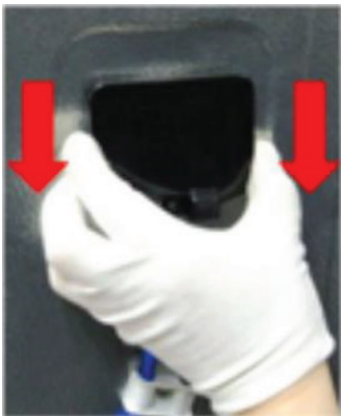

3. Pull outward on the blue water tube.



4. Using a Phillips screwdriver, remove the screw from the water pipe connector.

NOTE: The black line imprinted on the blue fill tube is a reference point. Only push the blue fill tube into the pipe connector until the black line is flush with the pipe connector opening on the rear of the cabinet.

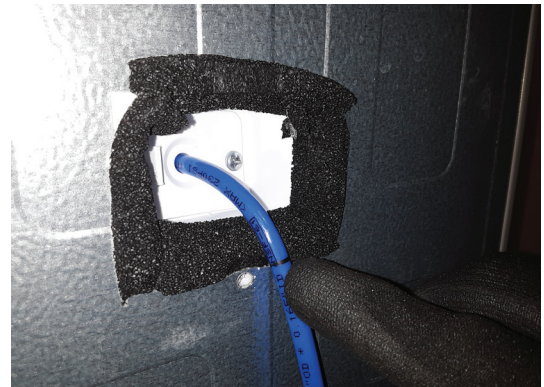

5. Grasp the water pipe connector with pliers, and pull the water pipe from the refrigerator.



Ice Maker Water Valve



The ice maker water valve is an electromechanical actuated solenoid valve used to control the flow of liquids and gases.

The electromagnetic solenoid activates the valve to allow water to flow to the ice maker.

The ice maker water valve corresponds with Pin No. 9 on CN2 of main board.

The coil resistance normal range: $2.2 \pm 0.2k$ ohms.

Refrigerant Flow Valve



Leak

1. Coat a solution of soap and water on the welding spot of the valve.
2. Pour refrigerant into the system. If a bubble appears, there is a leak in the electromagnetic valve.

8. Refrigerant System Repair

⚠ WARNING

Flammable refrigerant used.

Use only lock rings for R-600 sealed system repair connections.

Failure to do so can result in death, explosion or fire.

Refrigeration System

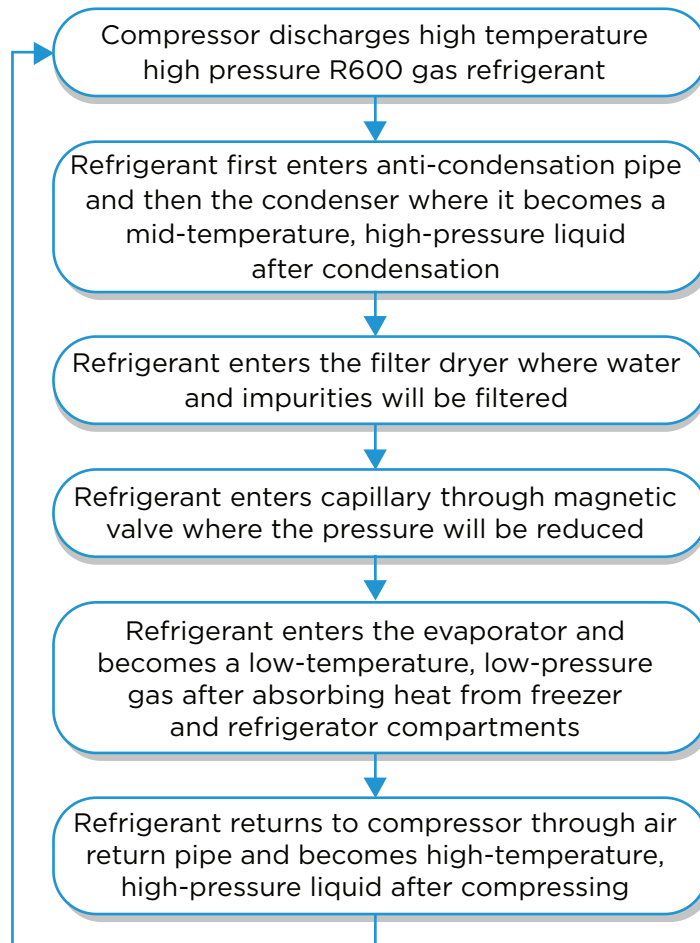

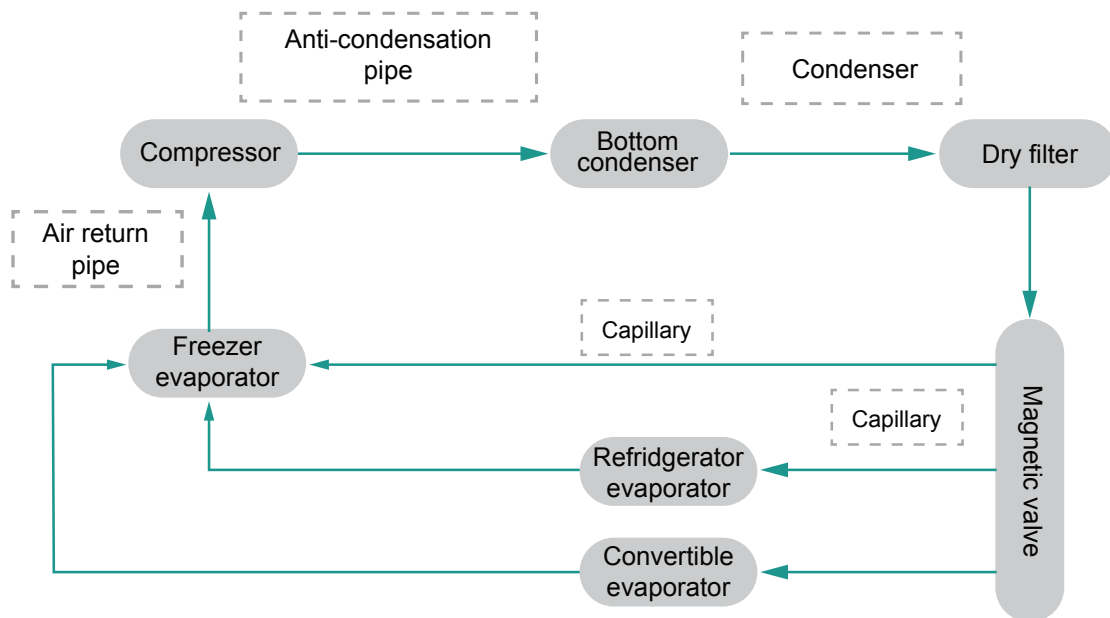

Repair Summary

PROCESS	CONTENTS	TOOLS
Remove refrigerant residuals	Cut charging pipe ends (Compressor and Dryer) and discharge refrigerant from dryer and compressor.	<ul style="list-style-type: none"> Nipper Side Cutters
Parts replacement	<ul style="list-style-type: none"> Confirm refrigerant (R-600) and oil for compressor and dryer. Confirm condition of N2 sealing and packing before use. Use good parts for assembly. Repair only in a clean and dry place. 	<ul style="list-style-type: none"> Pipe Cutter Lock Rings
Vacuum	<ul style="list-style-type: none"> After connecting manifold gauge hose, evacuate for more than 40 minutes and vacuum pump to high pressure side (dryer) and low pressure side (compressor). 	<ul style="list-style-type: none"> Vacuum Pump Manifold Gauge
Refrigerant charging	<ul style="list-style-type: none"> Weigh and control the cylinder in a vacuum condition with electronic scales and charge through compressor inlet (process tube). Charge while refrigerator is operating 	<ul style="list-style-type: none"> Mass Cylinder Refrigerant Manifold Gauge Electronic Scales Pinch-off Pliers
Check refrigerant leak and cooling capacity	<ul style="list-style-type: none"> Check for leak at lock ring joints <p>NOTE: Do not use soapy water for check.</p> <ul style="list-style-type: none"> Check cooling capacity <ul style="list-style-type: none"> Check condenser manually for warmth Check hot pipe manually for warmth Check for frost formation on the surface of the evaporator. 	<ul style="list-style-type: none"> Electronic Leak Detector Driver
Tools organization	<ul style="list-style-type: none"> Clean tools and store them in their designated place in a clean tool box 	<ul style="list-style-type: none"> Cleaning Cloth Tool Box

PROCESS	CONTENTS	TOOLS
Transportation and installation	<p>Installation should be conducted in accordance with the standard installation procedure. Maintain recommended clearances around the refrigerator.</p> <p>NOTE: For compressor compartment cooling fan mounted models leave a 2" space from the wall.</p>	

Repair Regulations

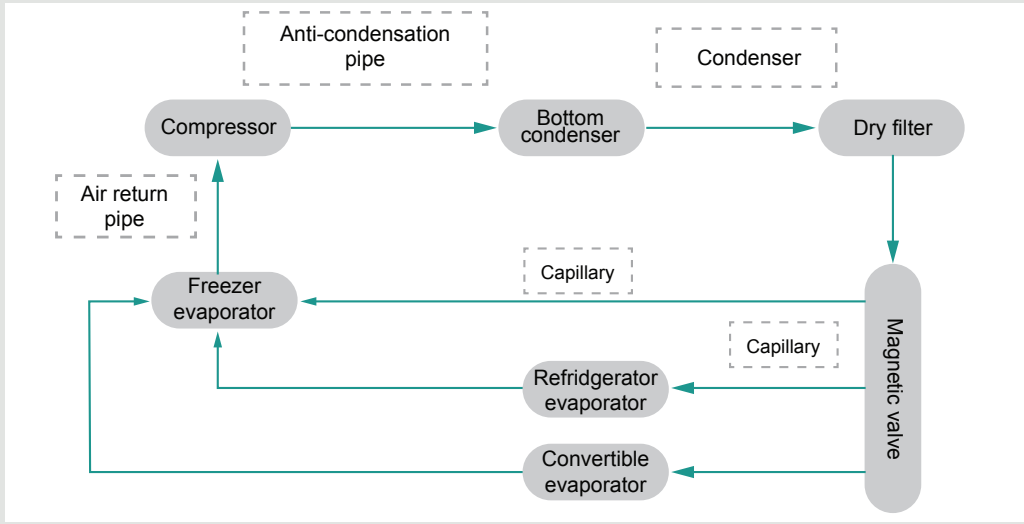
ITEMS	PRECAUTIONS
Use of tools	Use ONLY tools and parts suitable for R-600 refrigerant. Do NOT use a torch.
Removal of retained refrigerant	<ul style="list-style-type: none"> After turning off refrigerator, wait for longer than 5 minutes before removing retained refrigerant. Remove refrigerant, by using a nipper to first cut the high pressure side (Dryer), and then cut the low pressure side. <p>NOTE: An oil leak will occur, if this order is not followed.</p>  <p>The diagram illustrates the refrigerant cycle components and their connections. At the top, the 'Anti-condensation pipe' and 'Condenser' are shown in dashed boxes. The cycle starts with the 'Compressor' on the left, which connects to the 'Bottom condenser'. This leads to the 'Dry filter', which then connects to a vertical 'Magnetic valve'. From the magnetic valve, the cycle splits into two paths: one through a 'Capillary' tube to the 'Refridgerator evaporator', and another through another 'Capillary' tube to the 'Convertible evaporator'. Both evaporators connect to the 'Freezer evaporator'. From the freezer evaporator, the cycle goes through an 'Air return pipe' (shown in a dashed box) back to the compressor.</p>
Replacement of dryer	When repairing pipes and injecting refrigerant, replace the dryer with a new dryer.
Other	<ul style="list-style-type: none"> Nitrogen only should be used to clean and seal the inside of cycle pipes. Use an electronic leakage tester to check for leakage. Use a pipe cutter to cut pipes Do NOT allow water to enter the refrigerant system.

Repair Process

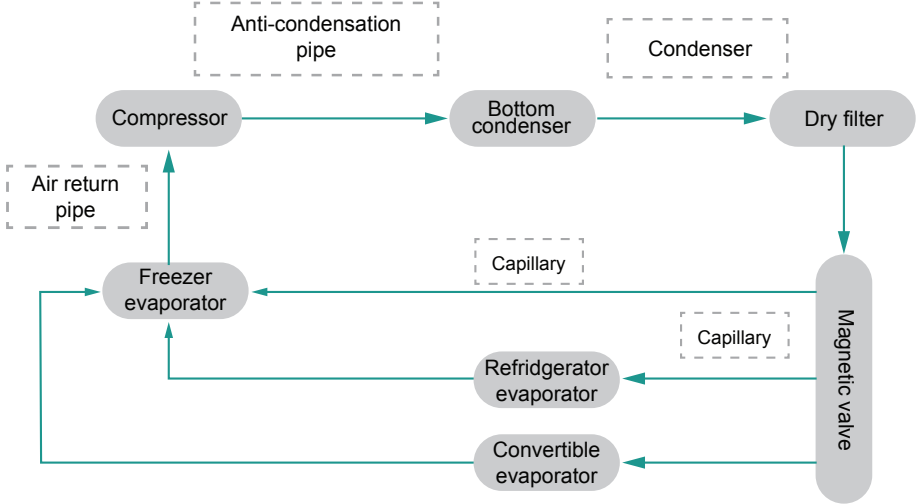
ITEMS	PRECAUTIONS
<p>Removal of residual refrigerant</p>	<p>After turning off refrigerator, wait for longer than 5 minutes before removing retained refrigerant.</p> <p>NOTE: If you do not wait the recommended length of time, compressor oil may leak inside.</p> <p>Remove refrigerant, by using a nipper to first cut the high pressure side (Dryer), and then cut the low pressure side.</p> <p>NOTE: An oil leak will occur, if this order is not followed.</p>  <pre> graph TD Compressor --> BottomCondenser[Bottom condenser] BottomCondenser --> DryFilter[Dry filter] DryFilter --> MagneticValve[Magnetic valve] MagneticValve --> RefrigeratorEvaporator[Refrigerator evaporator] RefrigeratorEvaporator --> ConvertibleEvaporator[Convertible evaporator] ConvertibleEvaporator --> FreezerEvaporator[Freezer evaporator] FreezerEvaporator --> AirReturnPipe[Air return pipe] AirReturnPipe --> Compressor Capillary1[Capillary] --- RefrigeratorEvaporator Capillary2[Capillary] --- FreezerEvaporator AntiCondensationPipe[Anti-condensation pipe] --- BottomCondenser Condenser --- BottomCondenser </pre>
<p>Sealed System Repairs</p>	<p>WARNING: Use ONLY lock rings for R600 sealed system repairs.</p>

ITEMS

Vacuum Degassing

PRECAUTIONS**Pipe Connection:**

Connect a red hose to the high pressure side and a blue hose to the low pressure side.

Vacuum Sequence:

Open Valves 1 and 2, and evacuate for 40 minutes.

Close Valve 1

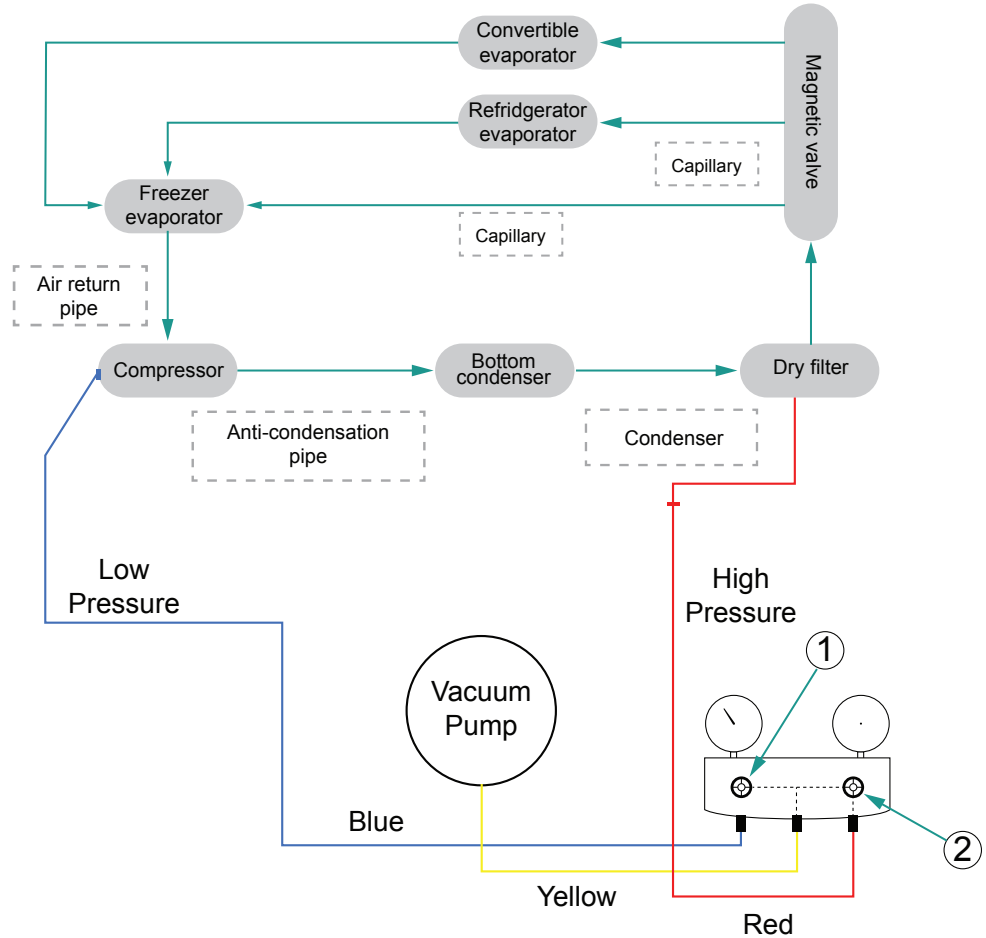
**IMPORTANT:**

If power is applied during vacuum degassing, vacuum degassing will be more effective.

Operate compressor while charging refrigerant. It is easier to charge.

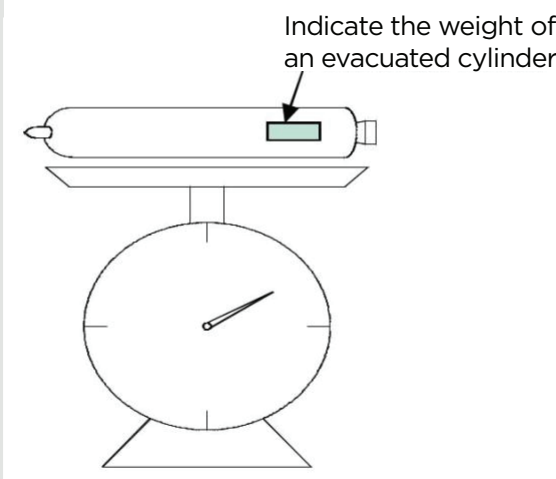
ITEMS	PRECAUTIONS
Refrigerant Charging	<ol style="list-style-type: none">1. After vacuum degassing, check the amount of refrigerant supplied to each model.2. Evacuate cylinder with a vacuum pump.3. Calculate the amount of refrigerant charged.<ul style="list-style-type: none">• Using an electronic scale, weigh the evacuated cylinder.• Charge refrigerant into a cylinder, and then weigh the cylinder.• Subtract the weight of an evacuated cylinder from the filled cylinder to calculate the weight of the refrigerant. <div data-bbox="683 459 1241 936" style="text-align: center;"><p>Indicate the weight of an evacuated cylinder</p></div> <p>IMPORTANT:</p> <ul style="list-style-type: none">• Charge the refrigerant at approximately 77°F.• Subtract 5g in the winter.• Add 5g in the summer.

9. Exploded Views/Parts List

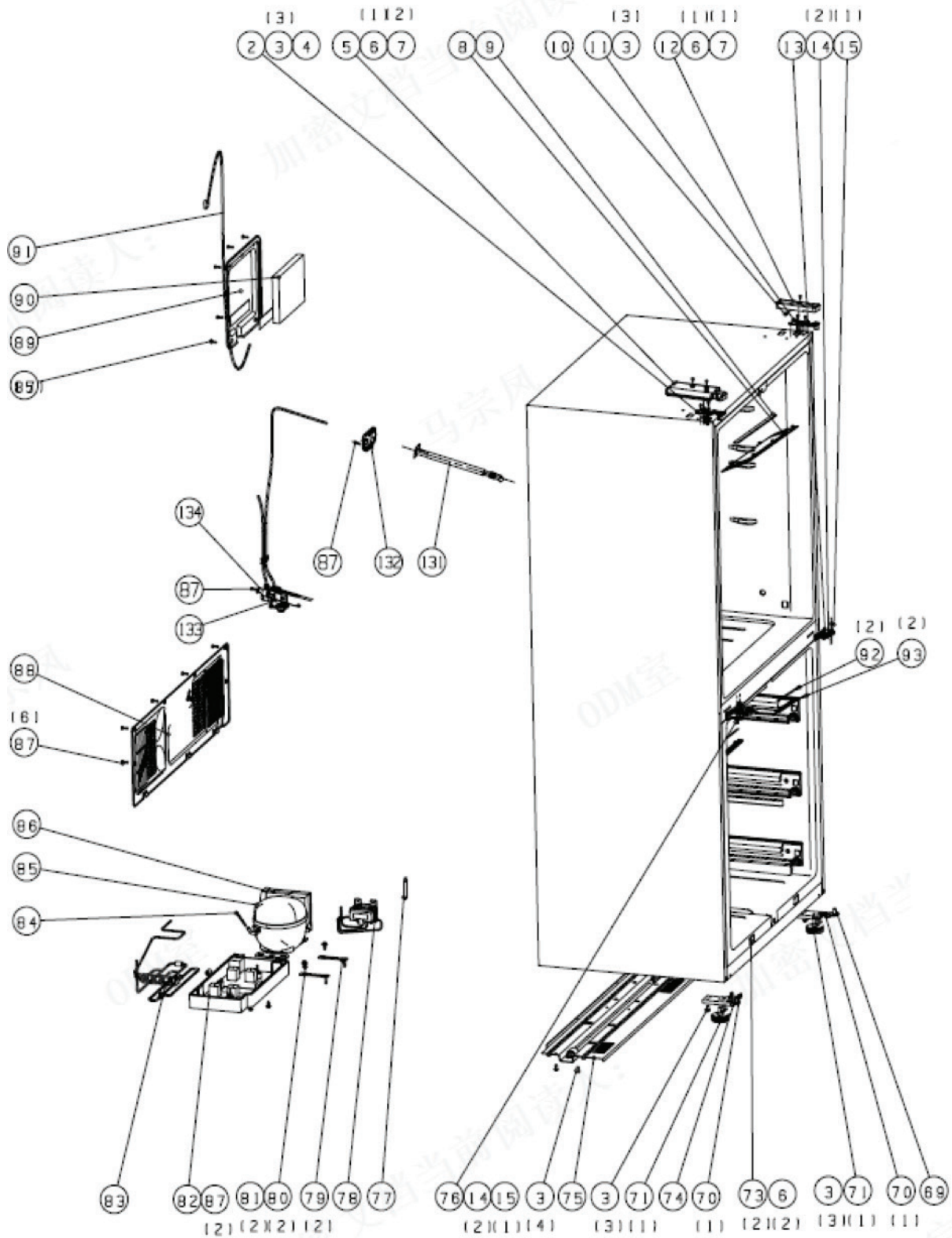

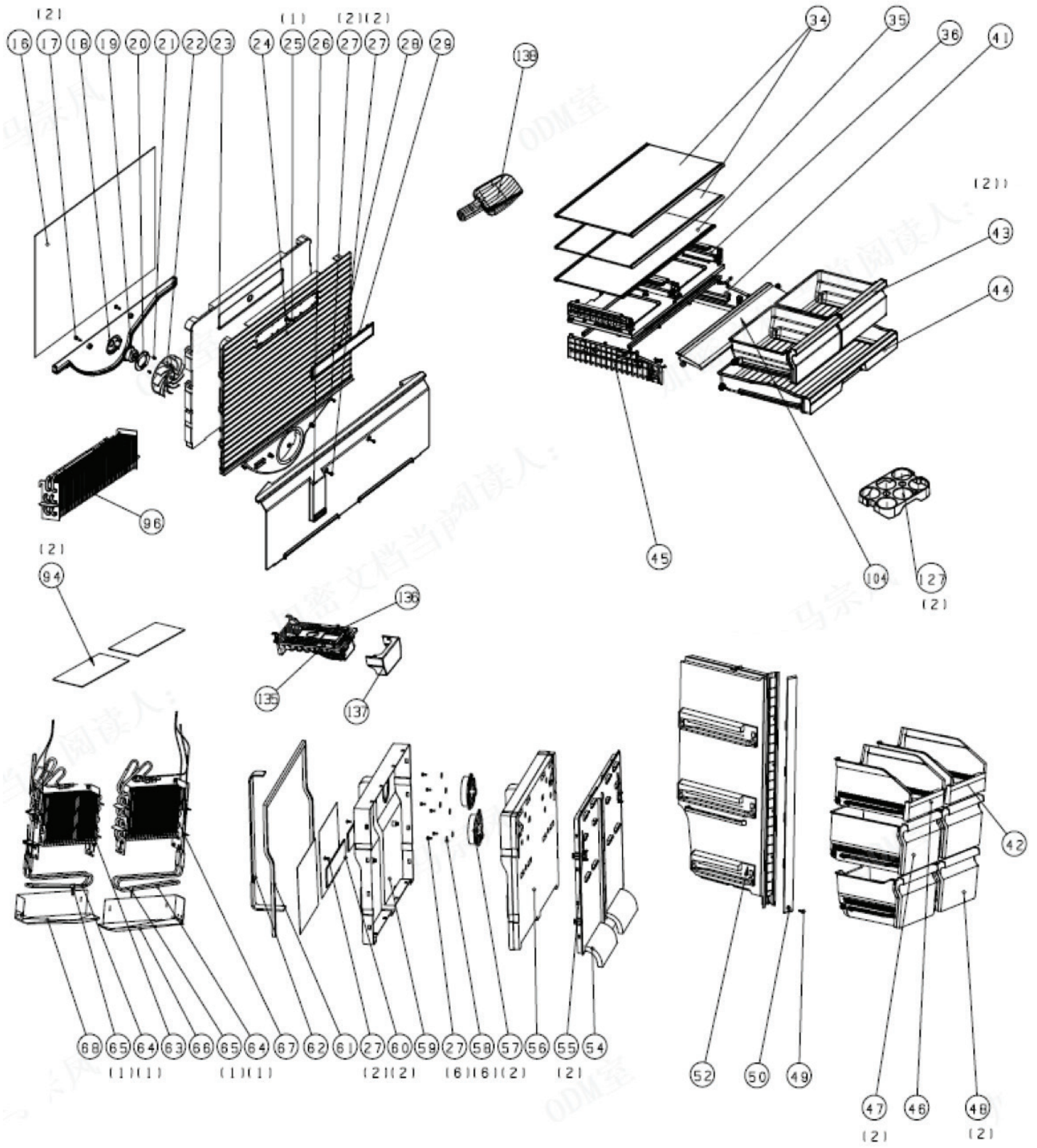

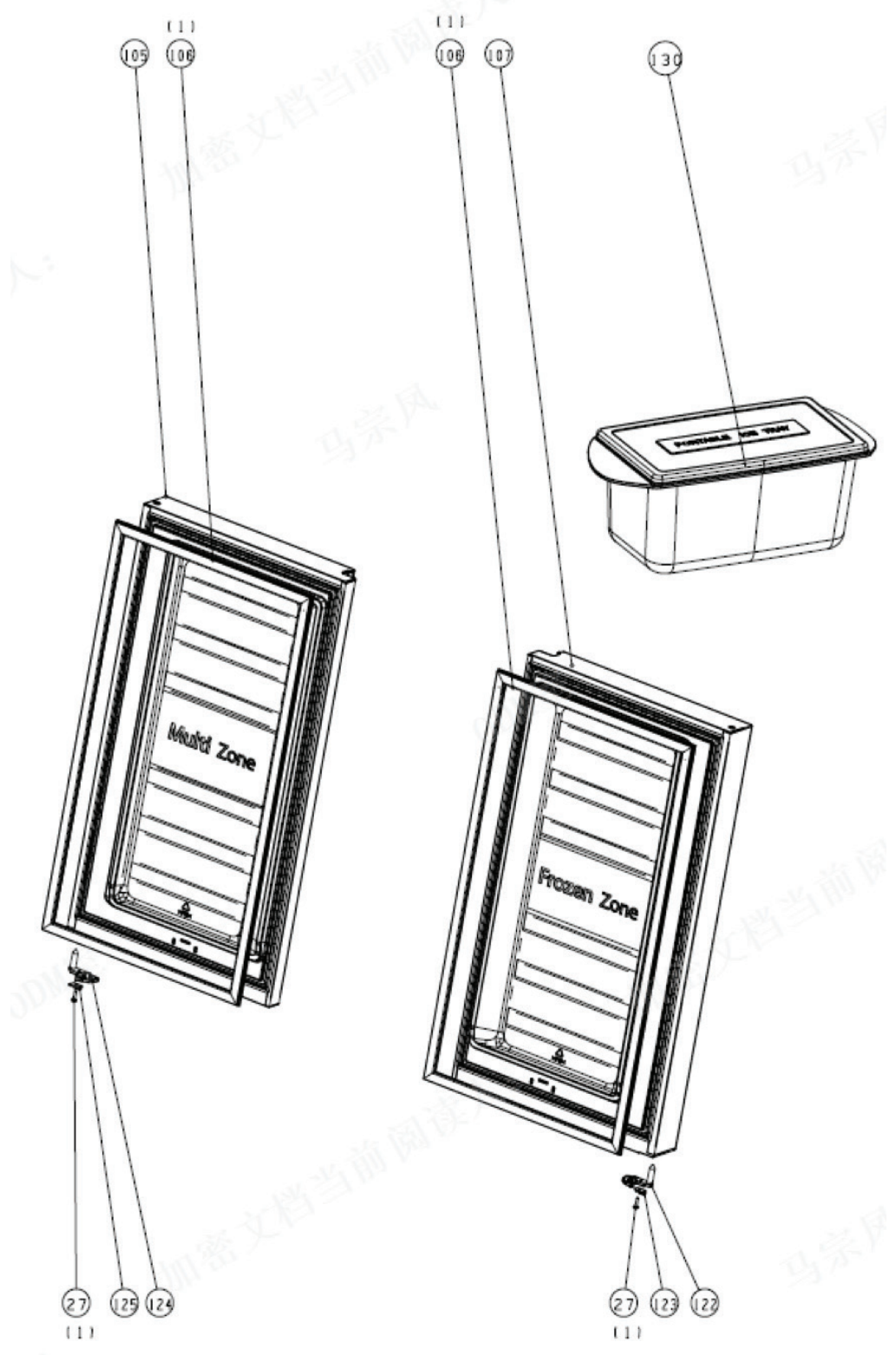

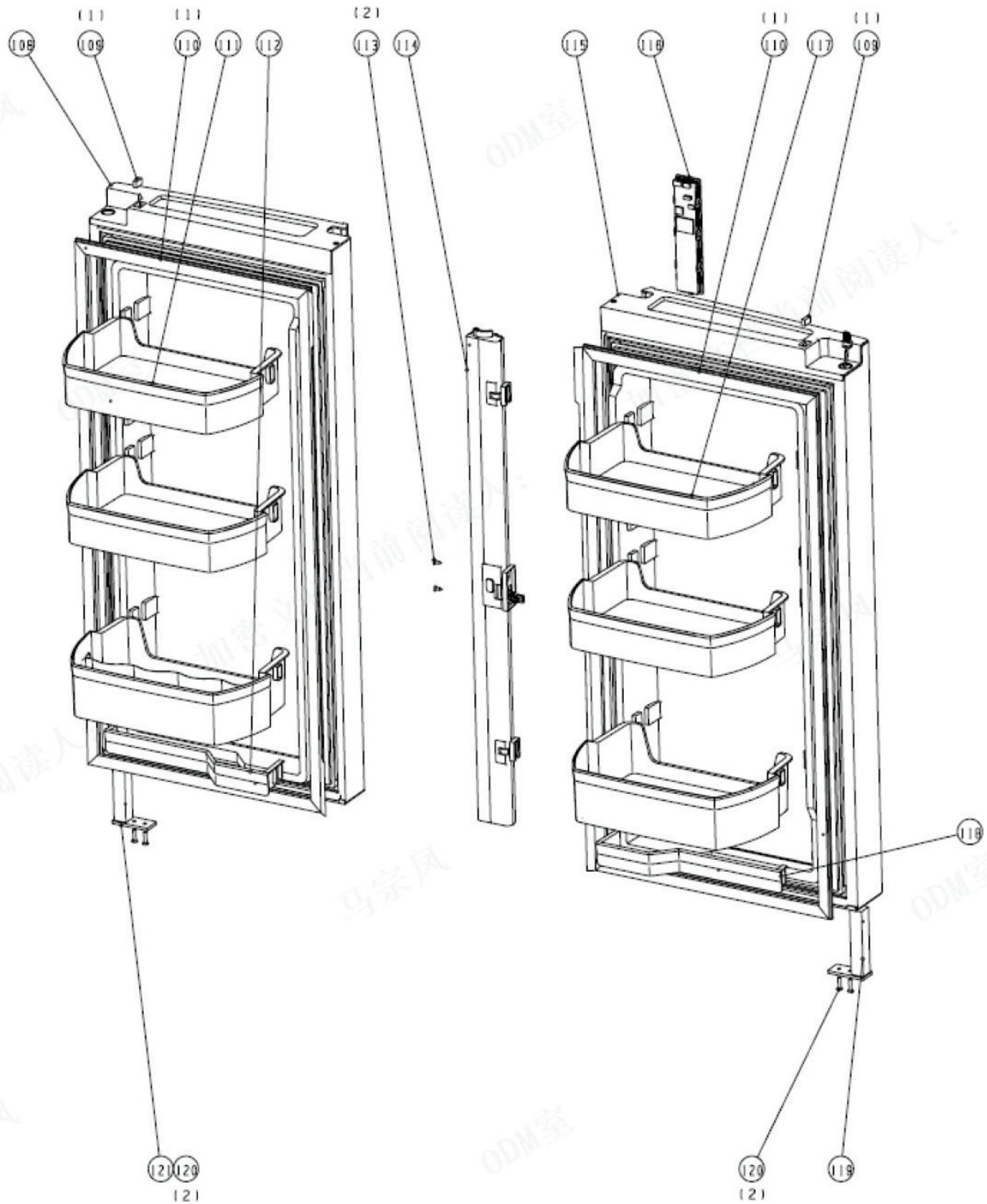

No	Part name	Part No
2	Left upper hinge part	1628544
3	Special flange self-tapping screw	1099098
4	Fastening components	1006880
5	Left upper hinge cover	1628547
6	Reed switch, all doors	1468523
7	Self-tapping screw	1351234
8	Light parts	1895817
9	LED light	1879352
10	Production bar code	1862533
11	Right upper hinge part	1628545
12	Right upper hinge cover	1628548

No	Part name	Part No
13	Right lower hinge part	1609332
14	Screw	1534952
15	Adjusting pad	1610145
16	Foam strip	1628516
17	Self-tapping screw	1099082
18	Motor fixed board	1608791
19	Refrigerator fan motor	1629352
20	Back fan motor cover	1620952
21	Self-tapping screw	1099032
22	Wind blade	1602291
23	Refrigerator wind channel foam	1608779

No	Part name	Part No
24	Refrigerator air duct cover	1866154
25	Self-tapping screw	1099068
26	Air return duct part	1608859
27	Self-tapping screw	1093509
28	Temperature sensor part	1430814
29	Wind channel cover part	1635203
34	Shelf part	1931297
35	Shelf part	1931325
36	Shelves assembly	1628556
41	Right drawer slideway	1880493
42	Upper drawer part	1984635
43	Crisper box part	1991160
44	Crisper box part	1964640
45	Left guided rail part for drawer	1880490
46	Upper drawer part	1991139
47	Middle drawer part	1991287
48	Lower drawer part	1991260
50	Clapboard beam	1628555
52	Middle clapboard parts	1875062
54	Wind channel board in freezer chamber	1874881
55	Temperature sensor part	1880241
56	Wind channel foam in freezer chamber	1875581
57	Continuous current dynamo	1877336
58	Gasket	1099120
59	Wind channel cover board in freezer chamber	1874882
60	Insulation floss	1879928
61	Sponge strip	1627901
62	Sponge block	1893638
63	Evaporator part	1879378
64	Tubular electric heater	1978490
65	Defrost stick	1603891
66	Water drain	1875232
67	Evaporator part	1879374
68	Water drain	1875231
69	Right lower hinge	1609250
70	Self-tapping screw	1129399
71	Ajustable bottom feet	1428670
73	Reed pipe cover	1467095
74	Left lower hinge part	1609323
75	Compressor base	1543316
76	Left lower hinge	1609331
77	Dry filter	1355792
78	Electric/Refrigerant valve	1932627
79	Platen	1094609
80	ScrewM6X25	1118349
81	Steel sleeve	1490994
82	Evaporating dish	1625624

No	Part name	Part No
83	Condensed water evaporation tube parts	1943170
84	Process tube	1639201
85	Compressor part	1984391
86	Frequency conversion plate part	1915647
87	Self-tapping screw	1099042
88	Compressor back guard	1647125
89	Control board box cover	1525980
90	Main control board	1978453
91	Power supply cord	1936481
92	LED light	1529227
93	Light cover	1539399
94	Glass shelf	1880087
96	Evaporator part	1609227
104	Drawer cover-drawing	1964641
105	V-Room door	1960720
106	Door gasket part	1907638
107	F-Room door	1960686
108	R2-Room door	4082850
109	Magnetic core	1467280
110	Door gasket part	1907637
111	Upper shelf	1965286
112	Lower cover part	1965299
113	Self-tapping screw	1635450
114	Vertical baffle part	1981905
115	R1-Room door	1976141
116	Functional board part	1979840
117	Upper shelf	1965288
118	Lower cover part	1965298
119	Middle hinge part	1628550
120	Middle hinge part	1099091
121	Middle hinge part	1628551
122	Door stopper	1467099
123	Door stop	1467096
124	Door stopper	1467078
125	Door stop	1467020
127	Egg tray	1413656

No	Part name	Part No
130	Ice box part	1898574
131	Two-way connector	1944415
132	Ice-maker inlet cover	1870522
133	Valve body	1995198
134	Electromagnetic valve fixed board	1979726
135	Automatic ice-maker part	1975580
136	Temperature sensor part	1648245
137	Ice tray cover	1992313
138	Ice shovel	1085333

Hisense
life reimagined