

Wine Cooler

SERVICE MANUAL

CAUTION

BEFORE SERVICING THE UNIT, READ THE "SAFETY PRECAUTIONS" IN THIS MANUAL.

MODEL: RW54N1SSD,RW46N1DSD

CONTENTS

SAFETY PRECAUTIONS	2
PARTS IDENTIFICATION	3
DISASSEMBLY	4-8
DOOR	4
SHELVES	4
LAMP	4
MAGNETIC SWITCHE	4-5
DISPLAY BOARD BOX ASSEMBLY	5-6
CONTROL BOARD & TRANSFORMER	6
SENSOR & FAN	6-8
TROUBLESHOOTING	9-12
COMPRESSOR COMPONENTS	9
ANOTHER ELECTRIC COMPONENT	10
SERVICE DIAGNOSIS CHART	11
REFRIGERATING CYCLE	12
DESCRIPTION OF CONTROL PCB	13

SAFETY PRECAUTIONS

Please read the followings before servicing your appliance.

1. Check if an electric leakage occurs in the set.
2. To prevent electric shock, unplug prior to servicing.
3. In case of testing with power on, wear rubber gloves to prevent electric shock.
4. If you use any appliances, check regular current, voltage and capacity.
5. Don't touch metal products in cold freezer with wet hand. It may cause frostbite.
6. Prevent water flowing to electric elements in mechanical parts.
7. When sloping the set, remove any materials on the set, especially thin plate type. (ex.: glass shelf or books.)
8. When servicing evaporator part, wear cotton gloves without fail. It is to prevent wound by sharp fin of evaporator.
9. Leave a breakage of refrigerating cycle to a heavy service center. The gas in cycle inside may soil ambient air.

2. PARTS IDENTIFICATION

Model: RW54N1SSD

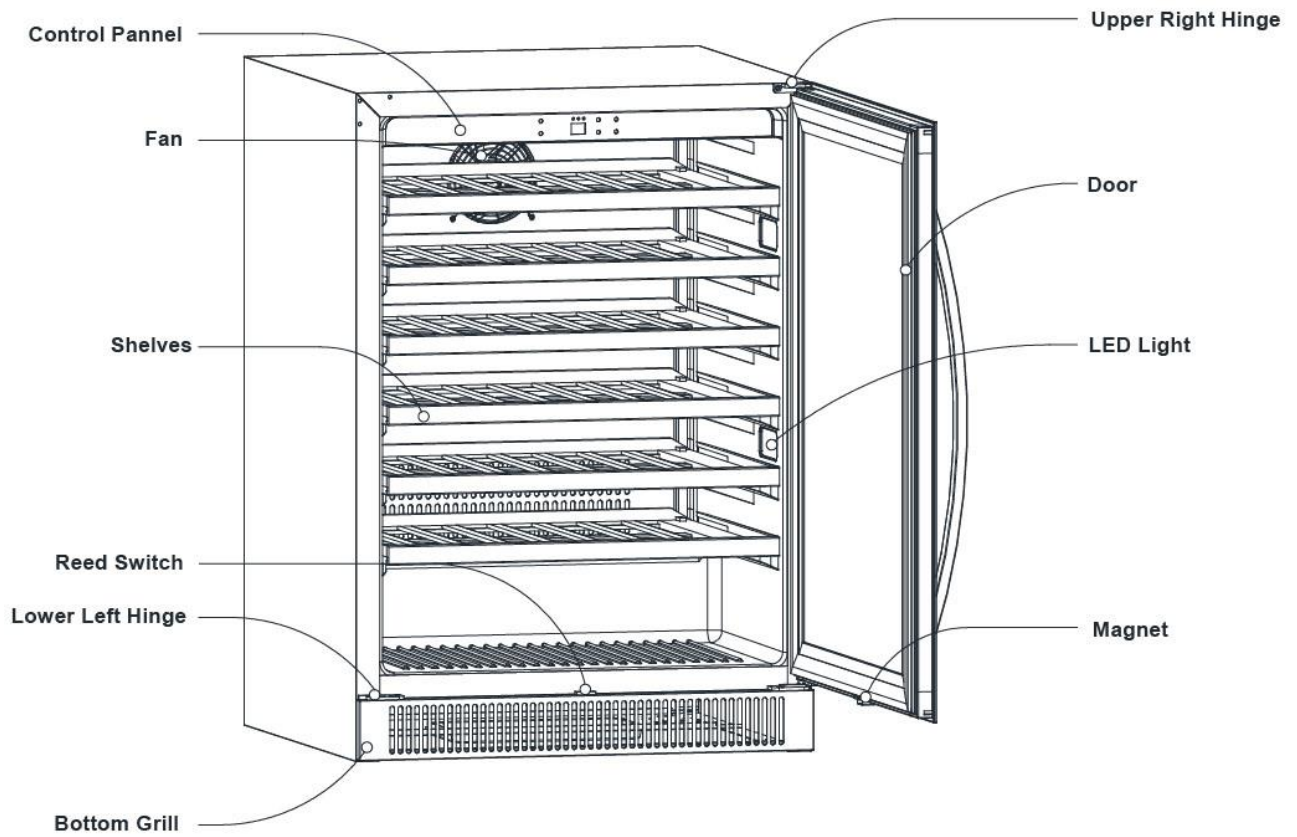

Model: RW46N1DSD

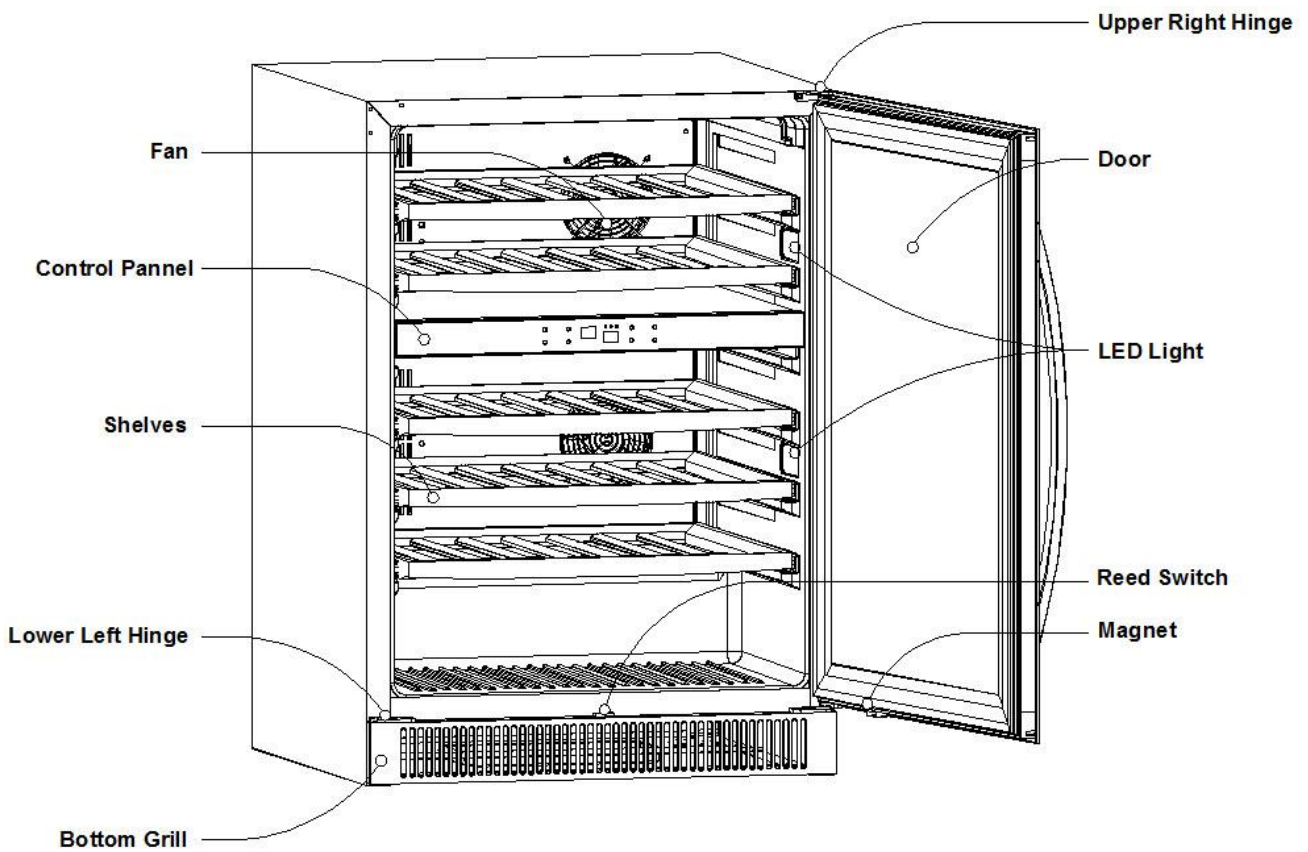

3. DISASSEMBLY

3-1 DOOR

- Loosen 2 bolts fixing the lower right hinge to the lower door axis to remove the door. (Figure 1)

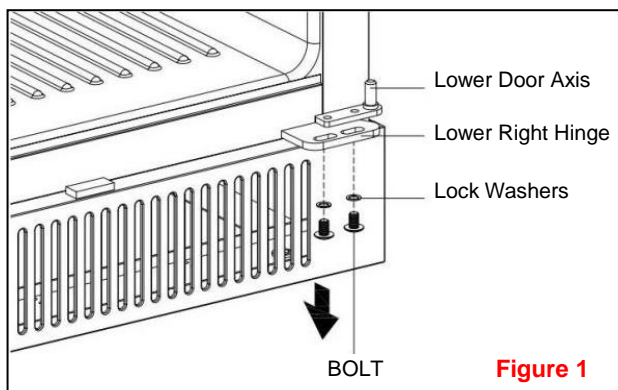

3-2 SHELVES

(Models: RW54N1SSD)

- The sides of the shelves are equipped with protective stoppers which prevent bottles from falling from the shelves.
- When removing / inserting the shelves from / into the rails, lift one side of the shelf as shown in (Figure 2) and pull the shelf out towards you, or push it in when inserting it, until one side is securely seated on the rail.

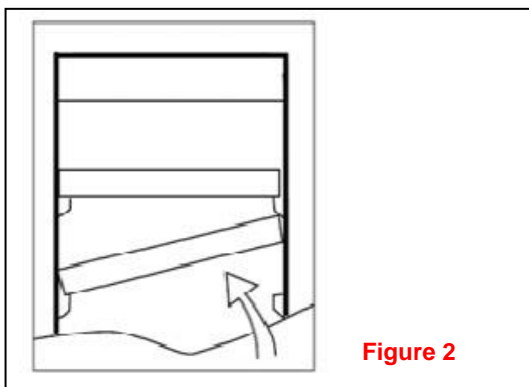

(Model: RW46N1DSD)

- To remove the shelves out of the rail, pull each shelf approximately 1/3 out. Use a long flat screwdriver or similar tool to press down the right plastic notch as shown in Figure 3 and at the same time lift the left plastic notch as shown in Figure 4. Then proceed to pull out the shelf slowly.
- When inserting the shelves make sure the shelf sides fix into the rails on both side and put to the end, and the shelf should be move smooth, if it is not smooth, rework it otherwise, the rails will be damaged.

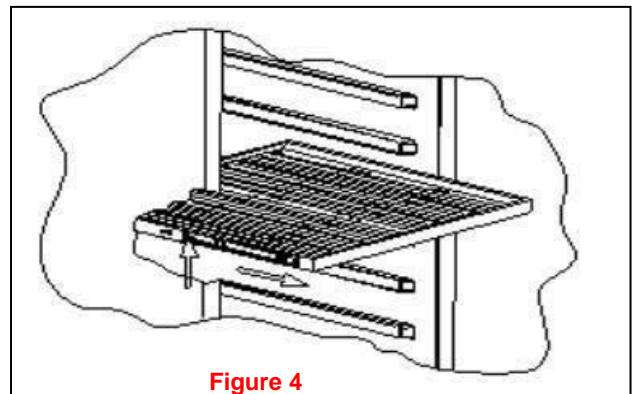
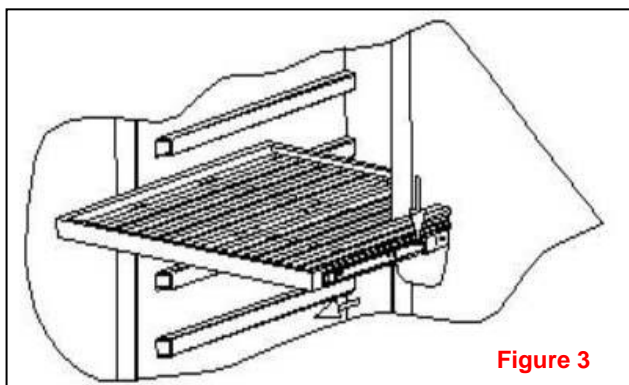

3-3 LAMP

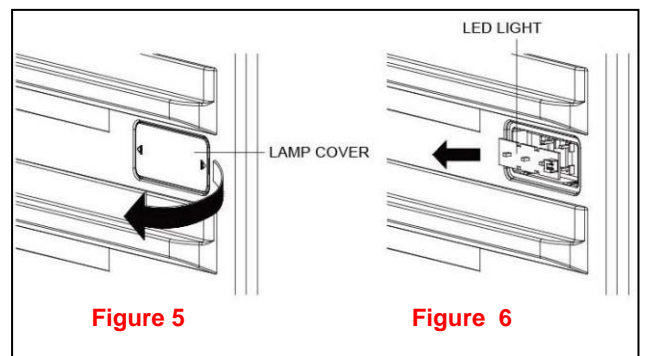

- Pull the lamp cover. (figure 5)(For RW46N1DSD remove the rail firstly)
- Separate the claw fixed to the LED light. Separate the lead wire Housing. (figure 6)

3-4 MAGNETIC SWITCH

- Loosen 5 screws.
- Separate the Support bracket of front leg. (Figure 7)

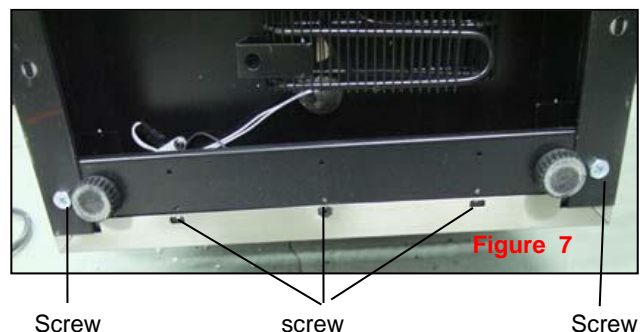

- Loosen 3 screws.
- Separate the lead wire Housing.
- Remove the bottom gill Assy. (Figure 8)

3. DISASSEMBLY

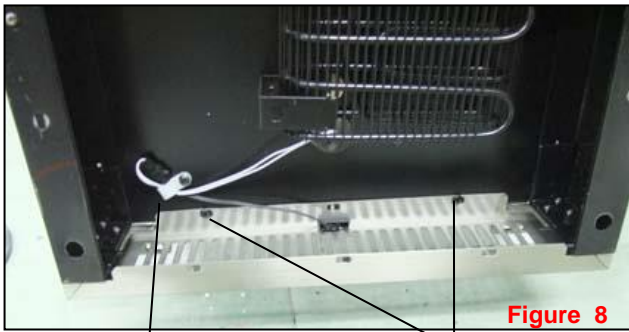

Wire Housing screw

6. Separate the magnetic switch. (Figure 9)

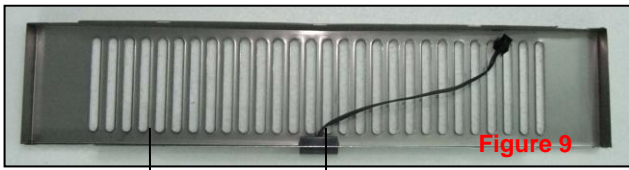

Bottom gill magnetic switch

3-5 DISPLAY BOARD BOX ASSEMBLY (Models: RW54N1SSD)

1. Loosen the screws. (Figure 10)



Screw Display board box Assy

2. Pull forward the Display board box Assy . (Figure 11)



Figure 11

3. The Display board box Assy. (Figure 12)

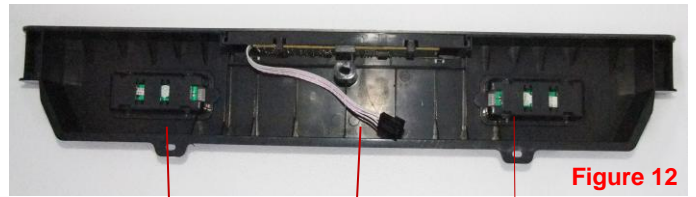

LED LIGHT Display board LED LIGHT

(Model: RW46N1DSD)

1. Separate the two screws under the Display board box Assy. (Figure 13)



Screw

Figure 13

2. Insert a screwdriver on the left hole. (Figure 14)



Figure 14

3. Pull forward the claw and raised the Display board box Assy a bit. (Figure 15)

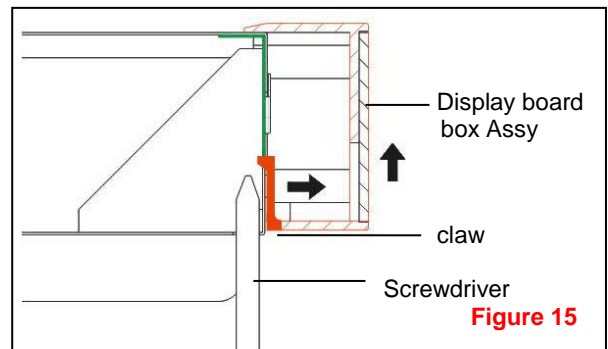

Display board box Assy

claw

Screwdriver

Figure 15

4. Repeat on the right hole. Separate the lead wire Housing. (Figure 16)



left hole

Wire Housing

right hole

Figure 16

3. DISASSEMBLY

5. The Display board box Assy. (Figure 17)

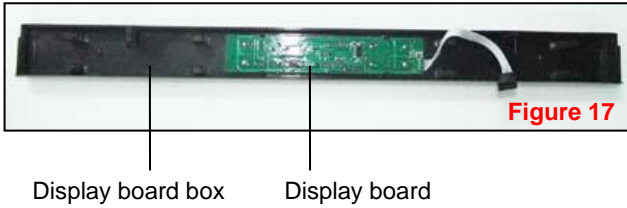

3-6 CONTROL BOARD & TRANSFORMER

1. Loosen the screws. Pull out the Control board box. (Figure 18)

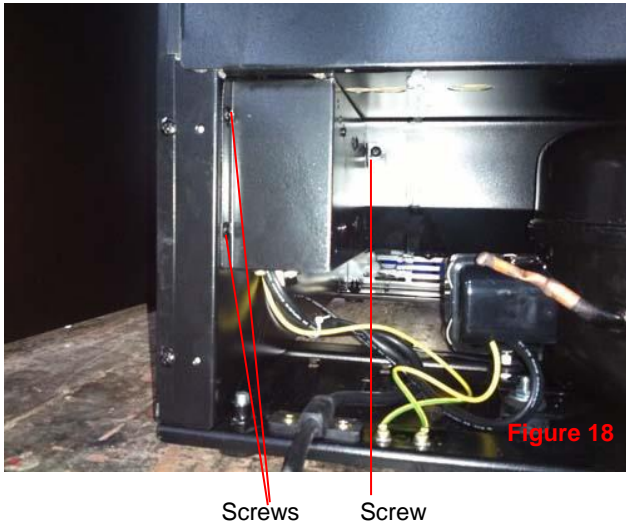

2. Separate the lead wire Housing. (Figure 19)

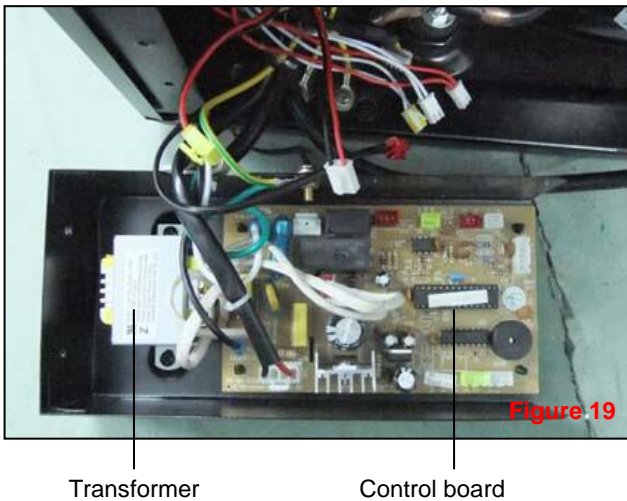

3-7 SENSOR & FAN

(Models: RW54N1SSD)

1. Loosen 6 screws. Pull out the rear air duct cover. (Figure 20)

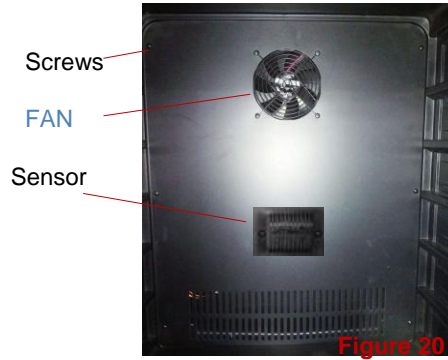

2. Loosen 1 screw. (Figure 21)

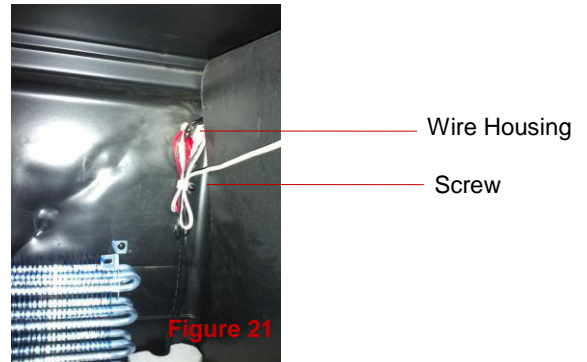

3. Press the nails with screwdriver at the back of the rear air duct cover. (Figure 22)



4. Separate the sensor cover. (Figure 23)



5. Separate the sensor. (Figure 24)



3. DISASSEMBLY

(Model: RW46N1DSD)

- 1. Remove the display board box Assy according 3-5
- 2. Separate the top plate of middle separator. (Figure 25)



- 3. Separate the LED light lead wire Housing. (Figure 26)



- 4. Loosen 3 screws. Pull out the bottom plate of middle separator. (Figure 27)

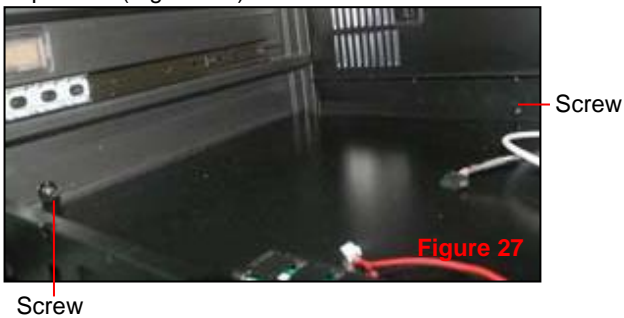

- 5. Loosen 6 screws. Pull out the rear air duct cover. (Figure 28)



- 6. Separate the lead wire Housings. (Figure 29)



- 7. The upper Fan, Sensor & lower Fan, Sensor. (Figure 30)

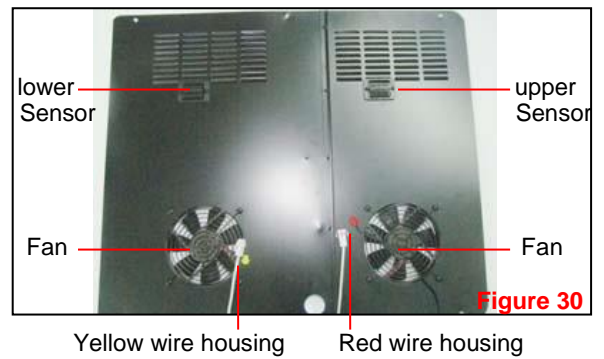

3. DISASSEMBLY

8. Press the nails with screwdriver at the back of the rear air duct cover. (Figure 31)



9. Separate the sensor cover. (Figure 32)



10. Separate the sensor. (Figure 33)



4. TROUBLESHOOTING

4-1 COMPRESSOR COMPONENTS

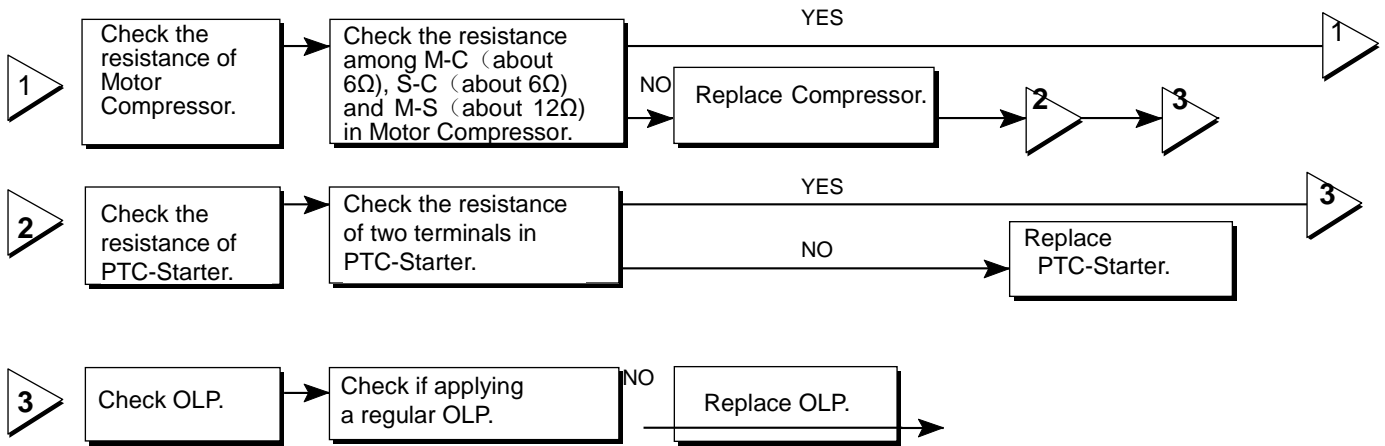

4-2 ANOTHER ELECTRIC COMPONENTS

▼ Cooling is impossible

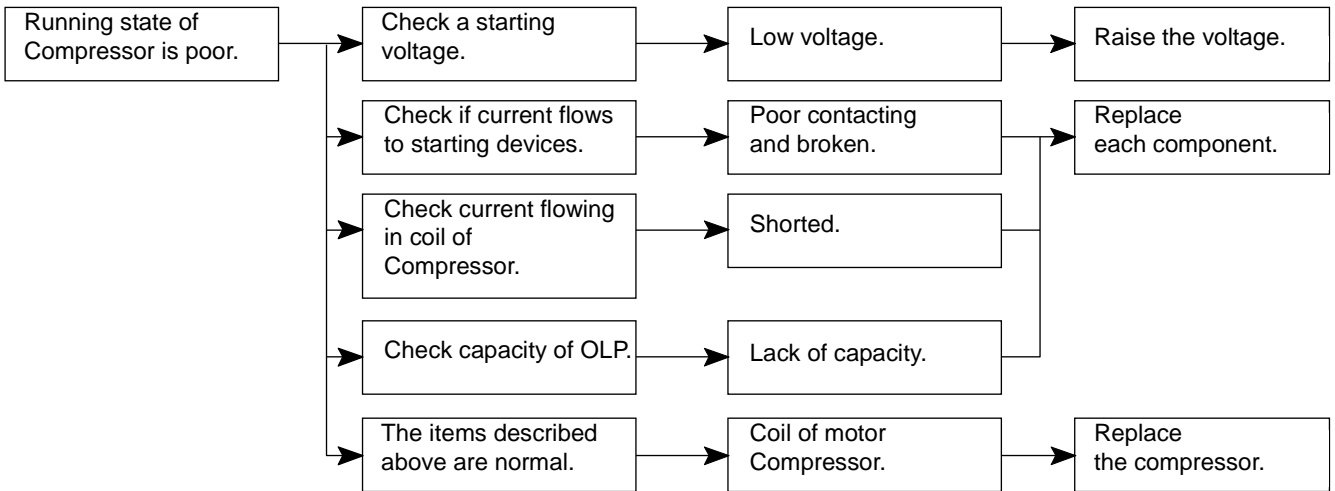
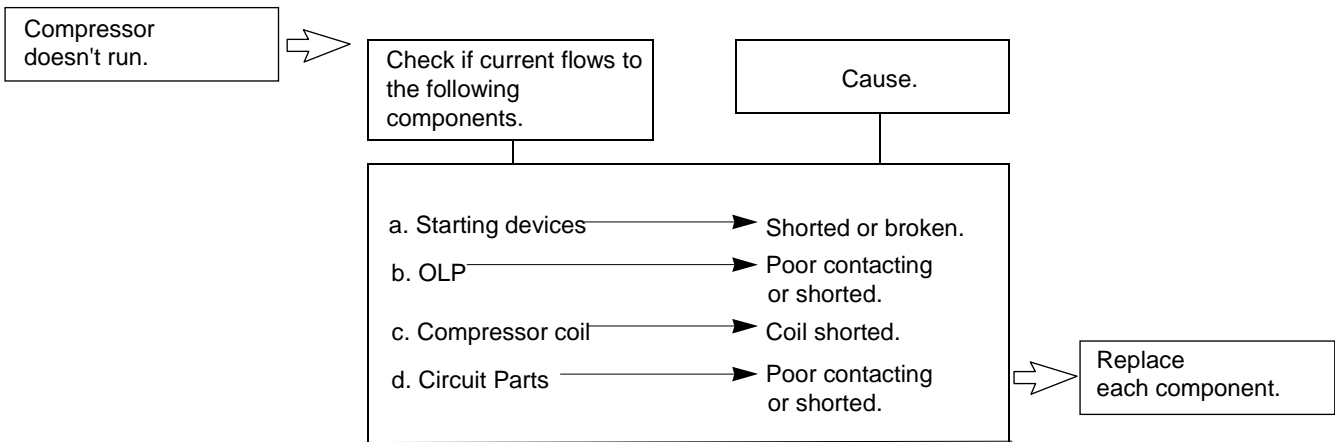

▼ Cooling ability is poor

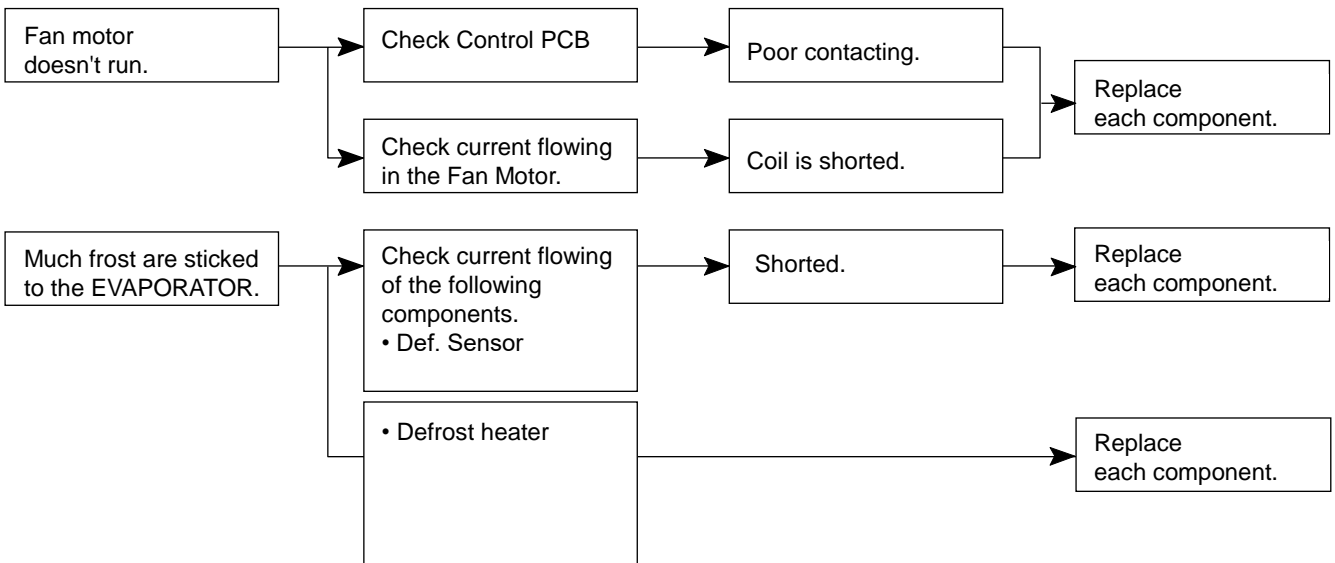

4-3 SERVICE DIAGNOSIS CHART

Problem	Possible Cause
Appliance does not operate.	Not plugged in. The appliance is turned off. The circuit breaker tripped or a blown fuse.
Appliance is not cold enough.	Check the temperature control setting. External environment may require a higher setting. The door is opened too often. The door is not closed completely. The door gasket does not seal properly.
NO cooling enough	The room temperature is hotter than normal. A large amount of contents has been added to the wine chiller. The door is opened too often. The door is not closed completely. The temperature control is not set correctly. The door gasket does not seal properly.
The light does not work.	Not plugged in. The circuit breaker tripped or a blown fuse. The bulb has burned out. The light button is "OFF". Energy conservation button is on.
Vibrations.	Check to assure that the Wine Chiller is level.
The Wine Chiller seems to make too much noise.	The rattling noise may come from the flow of the refrigerant, which is normal. As each cycle ends, you may hear gurgling sounds caused by the flow of refrigerant in your Wine Chiller. Contraction and expansion of the inside walls may cause popping and crackling noises. The Wine Chiller is not level.
The door will not close properly.	The Wine Chiller is not level. The door was reversed and not properly installed. The gasket is dirty. The shelves are out of position.
Display error code "E3" or "E4".	(Models: RW54N1SSD):The defrost sensor is failed.
Display error code "E7" or "E8".	(Models: RW46N1DSD):The lower zone sensor is failed.
Display error code "E0" or "E1".	(Models: RW54N1SSD):The inner sensor is failed. (Models: RW46N1DSD):The upper zone sensor is failed.

4-4 REFRIGERATING CYCLE

▼ Troubleshooting Chart

CAUSE		STATE OF THE SET	STATE OF THE EVAPORATOR	TEMPERATURE OF THE COMPRESSOR	REMARKS
LEAKAGE	PARTIAL LEAKAGE	Appliance don't get cold normally.	Low flowing sound of Refrigerant is heard and frost forms in inlet only	A little high more than ambient temperature.	<ul style="list-style-type: none"> • A little Refrigerant discharges. • Normal cooling is possible when injecting Refrigerant of regular amount.
	WHOLE LEAKAGE	Appliance don't get cold at all.	Flowing sound of Refrigerant is not heard and frost isn't formed.	Equal to ambient temperature.	<ul style="list-style-type: none"> • No discharging of Refrigerant. • Normal cooling is possible when injecting Refrigerant of regular amount.
CLOG	PARTIAL CLOG	Appliance don't get cold normally.	Flowing sound of Refrigerant is heard and frost forms in inlet only.	A little high more than ambient temperature.	<ul style="list-style-type: none"> • No discharging of refrigerant. • The capillary tube is faulty.
	WHOLE CLOG	Appliance don't get cold.	Flowing sound of Refrigerant is not heard and frost isn't formed.	Equal to ambient temperature.	<ul style="list-style-type: none"> • No discharging of Refrigerant.

▼ Leakage Detection

Observe discharging point of refrigerant which may be in oil discharging part in compressor and hole of evaporator.

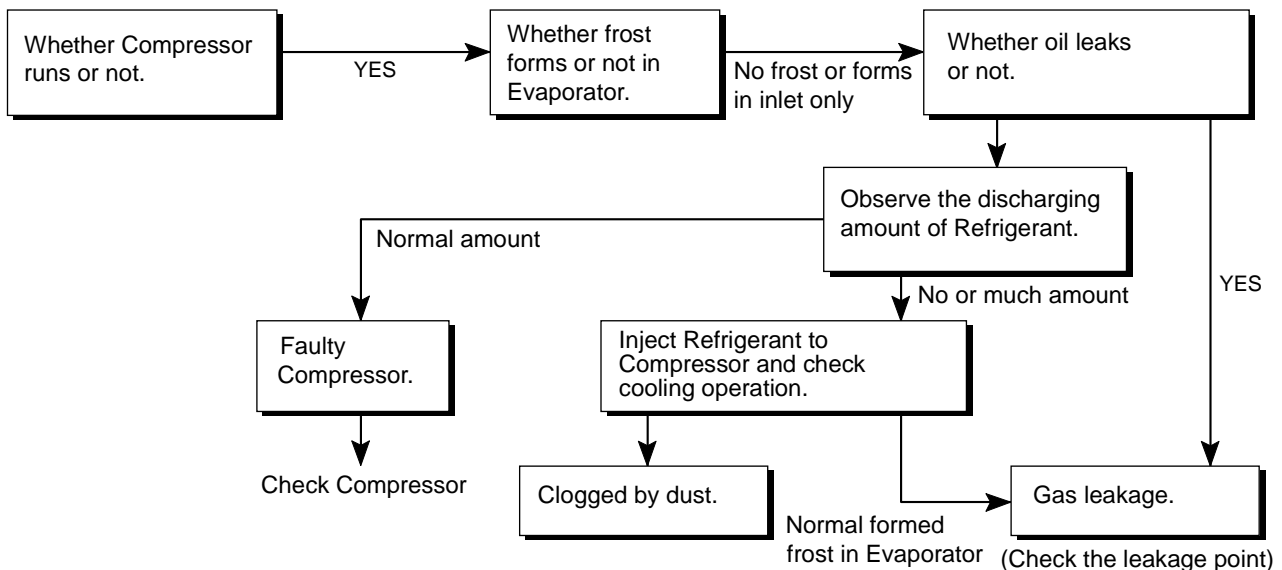

5. DESCRIPTION OF CONTROL PCB

(Models: RW54N1SSD) (Figure 34)

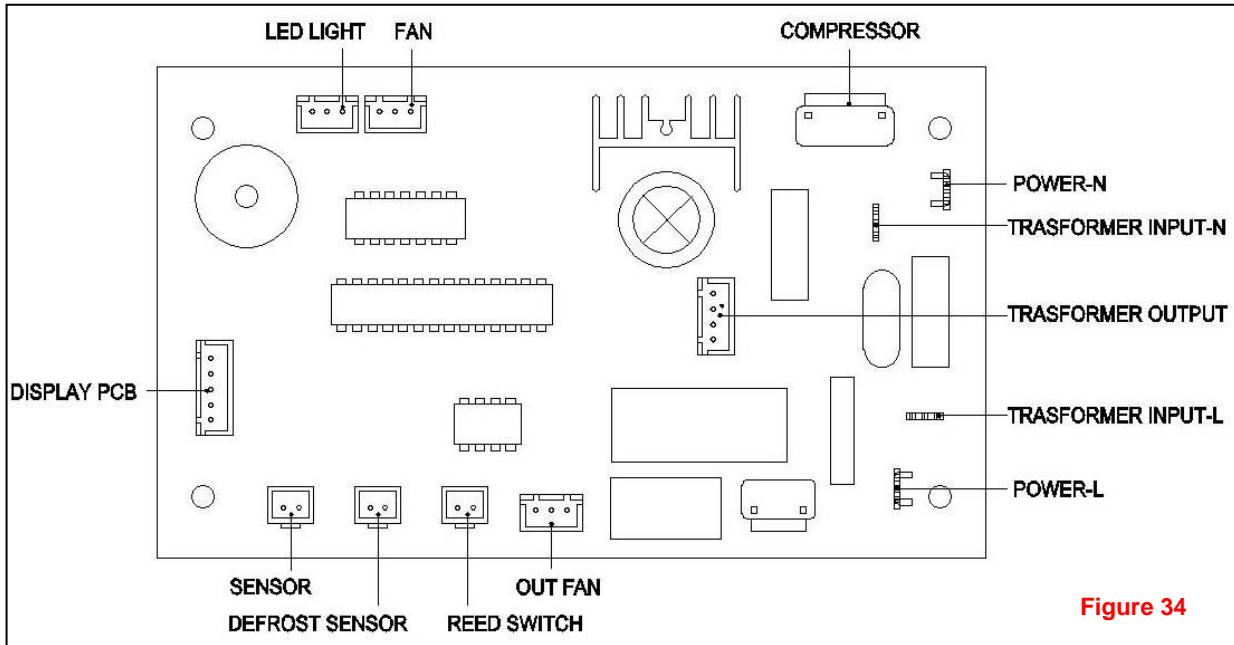

Figure 34

(Model: RW46N1DSD) (Figure 35)

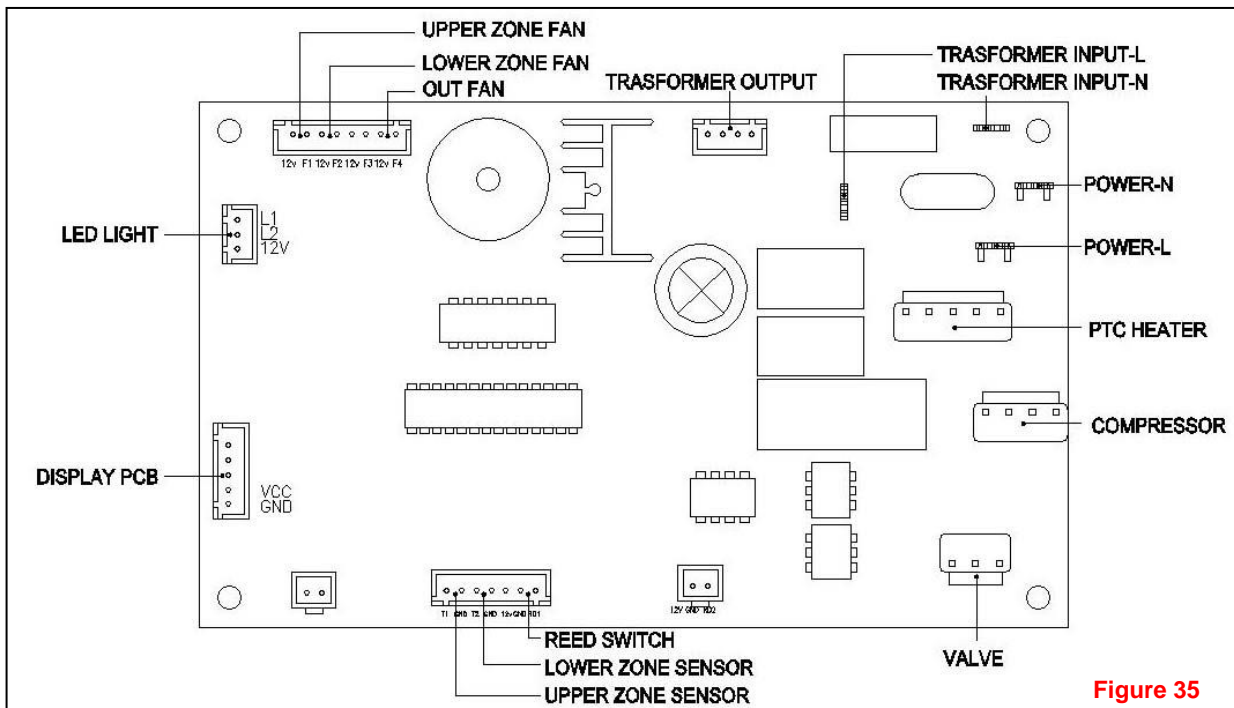

Figure 35